



EV9330-42

High Flow CSR Twin-MC System

Delivers premium quality water for combination applications



High Flow CSR Twin-MC System: EV9330-42

MC Replacement Cartridge: EV9612-06

EC210 Prefilter Cartridge: EV9534-26

SS-IMF Cartridge: EV9799-32

BENEFITS

One system provides premium quality water to high flow fountain, coffee and ice machines

Reduces chlorine taste and odor and other offensive contaminants that can adversely affect the taste of beverages

Precoat submicron technology reduces dirt and particles as small as 1/2 micron in size

Reduces health contaminants such as asbestos fibers and Cryptosporidium and Giardia cysts

Increases the overall efficiency of foodservice equipment

20" prefilter captures larger dirt particles and extends the life of the MC cartridges

SR-X with SS-IMF cartridge inhibits scale buildup in ice machines and coffee brewers

Sanitary cartridge replacement is simple, quick and clean. Internal filter parts are never exposed to handling or contamination

NSF Certified under NSF/ANSI Standards 42 and 53

INSTALLATION TIPS

Choose a mounting location suitable to support the full weight of the system when operating

Use 3/4" water line

Fountain equipment connections are made to the outlet part of the system before the SR-X system

Coffee brewer and ice machine connections are made after the SR-X feeder; a tee is required

Install vertically with cartridges hanging down. Allow 2-1/2" clearance below the cartridge for easy cartridge replacement

Flush cartridges by running water through flushing valve for five minutes at full flow

OPERATION TIPS

Change cartridges on a regular 6 month preventative maintenance program

Change cartridges when capacity is reached or when pressure falls below 10 psi

Change SS-IMF cartridge before Hydroblend™ compound is completely used up

Change prefilter cartridge when excessively dirty

Always flush the filter cartridge at time of installation and cartridge change

APPLICATION/SIZING

For multiple equipment and combination applications

Combination of coffee brewers, espresso machines, hot chocolate dispensers, fountain and ice machines

High Flow CSR Twin-MC System

SPECIFICATIONS

Overall Dimensions:
25.59"H x 25.8"W x 6.74"D

Inlet connection: 3/4"

Outlet connection: 3/4"

Service Flow Rate:
Maximum 3.34 gpm (12.6 Lpm)

Pressure Requirements:
10 - 125 psi (0.7 - 8.6 bar), non-shock

Temperature: 35 - 100°F (2 - 38°C)

No electrical connection required

Shipping Weight: 30 lbs.

Operating Weight: 42 lbs.

The contaminants or other substances removed or reduced by this drinking water system are not necessarily in your water. Do not use with water that is microbiologically unsafe or of unknown quality without adequate disinfection before or after the system. Systems certified for cyst reduction may be used with disinfected water that may contain filterable cysts.

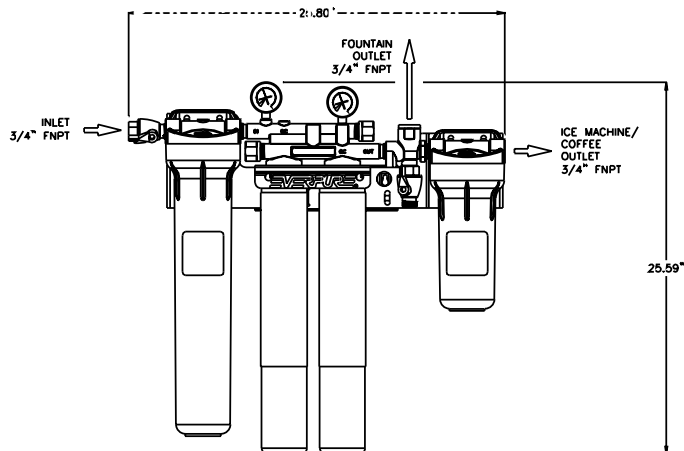

WARRANTY

Everpure water treatment systems (excluding replaceable elements) are covered by a limited warranty against defects in material and workmanship for a period of five years after date of purchase. Everpure replaceable elements (filter cartridges and water treatment cartridges) are covered by a limited warranty against defects in material and workmanship for a period of one year after date of purchase. See printed warranty for details. Everpure will provide a copy of the warranty upon request.



System Tested and Certified by NSF International against NSF/ANSI Standard 42 and 53 for the reduction of:

Standard No. 42: Aesthetic Effects
Chemical Unit
Taste and Odor Reduction
Chlorine Reduction
Mechanical Filtration Unit
Particulate Reduction, Class I:
99.9+% reduction of particles
one-half micron and larger in size
Standard No. 53: Health Effects
Mechanical Filtration Unit
Turbidity Reduction
Cyst Reduction
Asbestos Reduction



EVERPURE, INC.
2375 Sanders Road
Northbrook, IL 60062
Toll Free (800) 323-7873
Tel (847) 205-6000
Fax (800) 942-0081
<http://www.everpure.com>

In Europe:
N.V. EVERPURE (EUROPE) S.A.
Geldenaaksebaan 478
B-3001 Heverlee
Belgium
Tel 32-16-401191
FAX 32-16-402691

In Japan:
EVERPURE JAPAN, INC.
1-8-19, Tsumada Kita,
1-Chome, Atsugi City
Kanagawa Ken 243-0812
Japan
Tel 81-462-23-6563
FAX 81-462-21-6775

Everpure, Inc.
2375 Sanders Road
Northbrook, IL 60062
Phone: 800-323-7873 Fax: 800-942-0081