

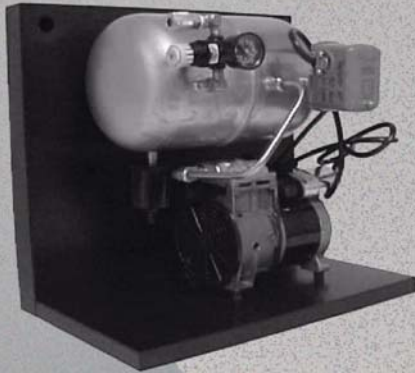

McCann's

BIB Air Pumping Station

3 Models: Wall, Floor or Shelf Mounted



**Model 99-2201
Wall-Mount**

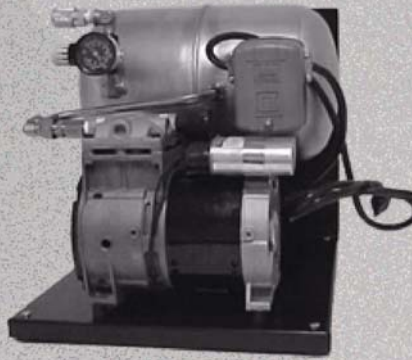

**Model 99-2001
Floor-Mount**

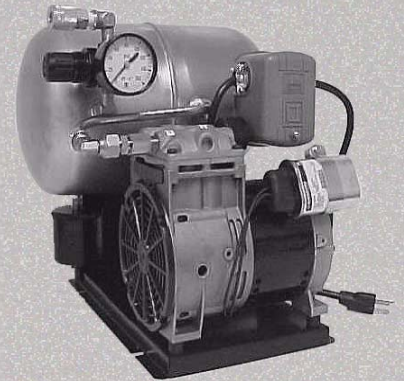

**Model 99-2101
Shelf-Mount**
(for use on 2 or 3 wide BIB top shelf)

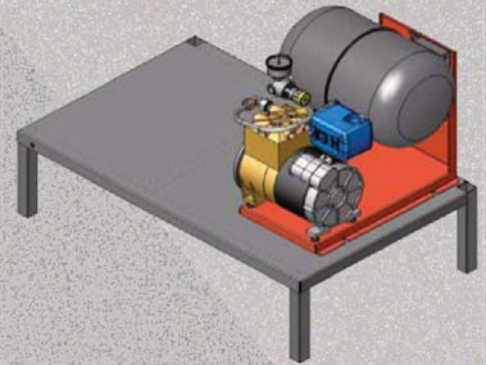

Gulf ICE Systems, Inc.

SPECIFICATIONS

- The BIB Air Pumping Station is economical and designed for use with BIB pumps.
- Each model uses a piston style compressor and stainless steel tank.
- The air station incorporates an automatic pressure switch, preset for **60 PSI on** and **80 PSI off**.
- The air station is designed to operate 3 BIB pumps simultaneously

ELECTRICAL

- All models are offered with either 115v, 60 cycle or 220v, 50 cycle power supply.

FEATURES

- Quick disconnect (standard on all models)
- Self draining condensation valve
- Pressure regulator with gauge
- Model 99-2101 can be mounted on the left or right side of the BIB top shelf

