

SUPER ASTRA REMOTE COOLING UNIT



FEATURES

Consistency - Maintain beverage temperature in short run set ups

Environmentally responsible - R134a refrigerant

Small footprint - Size allows for undercounter placement

Durable - Constructed for today's harsh environments

Powerful - 1/2 HP compressor

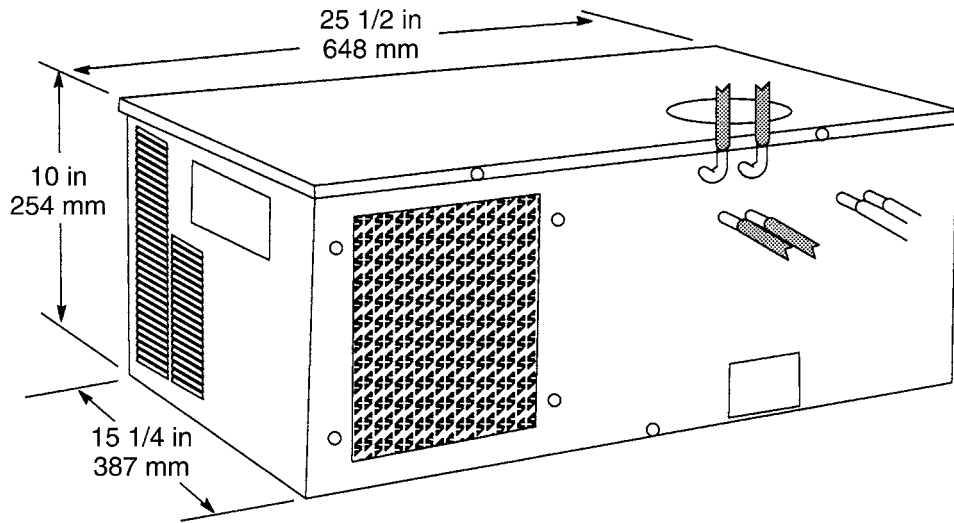

PART NUMBER	DESCRIPTION
48186G052	Super Astra Remote Cooling Unit

TECHNICAL SPECIFICATIONS

COMPRESSOR 1/2 HP 373 Watts
 REFRIGERANT R-134a
 MAXIMUM RECOMMENDED
 LENGTH OF PYTHON 120" (3048 mm)
 WATER BATH CAPACITY 3 gal (11.4 L)
 ICE BANK SIZE 20 lb (9 kg)

RECOVERY TIME 2.5 hr
 ELECTRICAL REQUIREMENTS .. 120 V / 60 Hz / 7.2 Amps
 SHIPPING WEIGHT 76 lb (35 kg)

AGENCY LISTINGS

