

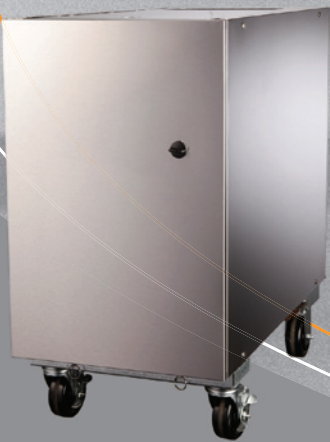

## **VIPER CARTS**

FOR FROZEN CARBONATED  
BEVERAGE DISPENSERS

**VIPER 2 FLAVOR CART**



**VIPER 3 FLAVOR CART**



**VIPER 4 FLAVOR CART**



### **FEATURES:**

- Stainless steel side panels
- Provides storage for Syrup BIB and BIB pumps
- Includes casters

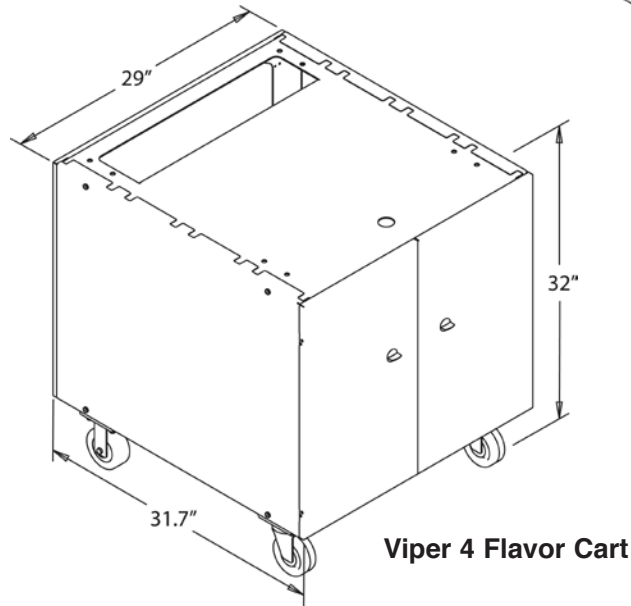
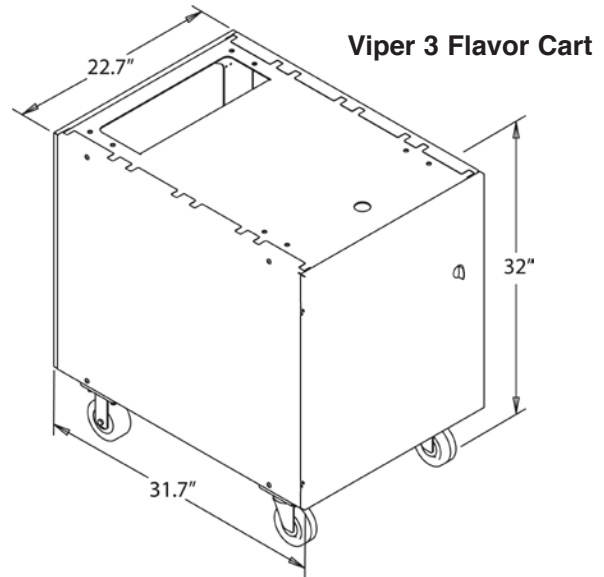
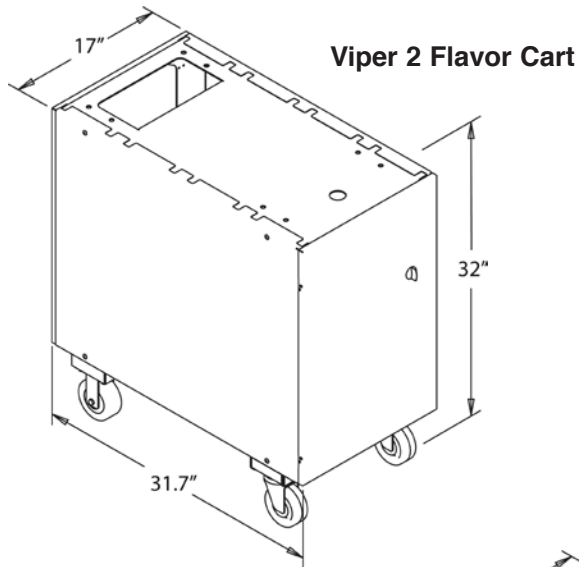

PART NUMBER	DESCRIPTION
620043075	Viper 2 Flavor Cart, Stainless Steel Side Panels
620053990	Viper 3 Flavor Cart, Stainless Steel Side Panels
620046556	Viper 4 Flavor Cart, Stainless Steel Side Panels

**TECHNICAL SPECIFICATIONS:**

SHIPPING WEIGHT . . . . . 620043075: 175 lb (79.3 kg)  
 620053990: 175 lb (79.3 kg)  
 620046556: 200 lb (90.7 kg)

