

Ice-O-Matic®

EF250 - Self Contained Flake Ice Maker



EF250

Features

- Produces up to 400 lbs (182 kg) of ice per day.
- Constructed with a rugged stainless steel transport system enclosed in polyurethane insulation.
- Removes excess water by pushing the flaked ice through an extrusion process—the result is high quality flaked ice which is ideal for medical, supermarket or restaurant applications.
- Constructed from sturdy, corrosion-resistant stainless steel.
- Filter Free Air -No air filter to change.

Options & Accessories

Water Filters			
Ice Machine Model	Manifold		Inline
	System	Replacement	System
EF250	IFQ1	IOMQ (1)	IFI4C / IFI8C

Ice Maker Warranty

Every Ice-O-Matic ice maker is backed by a warranty that provides both parts and labor coverage.

Parts & Labor

- Two years **Parts** and **Labor**.
- Five years **Parts** coverage on the compressor

Ice Form



Space-Saving Solutions

- Self-contained insulated storage available in 143 lbs (65 kg) or 213 lbs (97 kg).
- Your choice of 32" (813 mm) or 38" (965 mm) wide cabinets.
- Ultra low profile - 41" (1041mm) tall
- Air intake on only 1 side



Ice-O-Matic

EF250 Self Contained Flake Ice Maker

Air Cooled

Please note: air-cooled units require 6" (152 mm) clearance for air intake and exhaust.

- A. Ice maker potable water in, 3/8" FPT.
- B. Drain, 1/2" i.d. plastic tubing.
- C. Hole for electrical connections.
- D. 3/4" Bin Drain

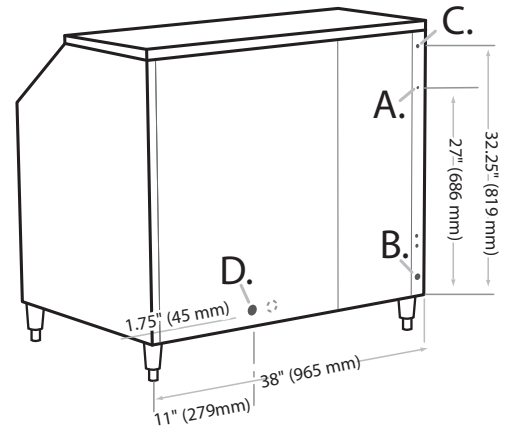
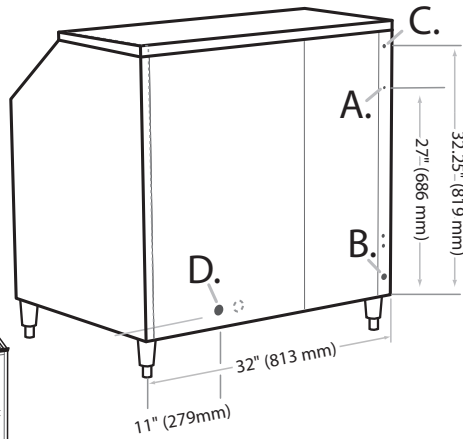
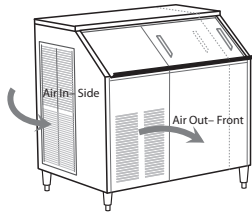

Rear View

Operating Requirements

	Minimum	Maximum
Ambient Temp. Range Air	50°F (10°C)	110°F (43°C)
Water Temp.	40°F (4.4°C)	100°F (38°C)
Water Pressure	20 PSIG (1.4 BAR)	60 PSIG (4.1 BAR)

Dimensions

Models	Size	
	W x D x H (inches)	W x D x H (mm)
EF250A32S	32" x 28" x 41"	813 mm x 711 mm x 1,041 mm
EF250A38S	38" x 28" x 41"	965 mm x 711 mm x 1,041 mm

Specifications

Model Number	Cabinet Width inch (mm)	Bin Size lbs (kg)	Cond. Unit	Ice Production per 24hrs		Water Usage gallons per 100 lbs of ice 90°F air/ 70°F water	kWH Used per 100 lbs of ice @ 90°F air/ 70°F water	Voltage Characteristics	Min. Circuit Ampacity	Fuse Size	Approx. BTUs per hour
				70°F air/ 50°F water lbs (kg)	90°F air/ 70°F water lbs (kg)						
EF250A32S	32 (813)	143 (65)	Air	400 (182)	319 (145)	12	5.6	115/60/1	12.4	15	4,233
EF250A38S	38 (965)	213 (97)	Air	400 (182)	319 (145)	12	5.6	115/60/1	12.4	15	4,233

NOTES:

Number of Wires: 3 (including ground)
 Approx. Shipping Weight lbs (kg): EF250A32S 240 (109) • EF250A38S 250 (114)
 Refrigerant Type: R404A