



IMD-300-15

Ice Maker/Dispenser



Features:

- CFC-free, R-134a refrigerant
- Compact, only 15" of counter space – 10% less than comparable units
- Over 13 lbs. of ice storage – 45% more than comparable units
- Up to 265 lbs. of capacity per day – 18% more than comparable units
- Standard ice and water dispensing
- Removable, easy to clean air filters
- Ideal for hospitals and nursing homes
- CFC-free foam insulation
- Cube size 3/8"W x 1/2"H x 1/2"D



IMD-300-15

Technical Specifications:

Compressor: 1/3 H.P.

Refrigerant: CFC-free, R-134a

Voltage: 115 / 60, 220 / 50, 208-230 / 60

Minimum Circuit Amps: 15

Ice Bin Storage Capacity: 13 lbs. (5.9 kg)

Ice Production Capacity (60 cycle):

246 lbs. per day @ 70°F Air/50°F Water
(111.68 kgs. @ 21.09°C Air/10.0°C water)

202 lbs. per day @ 90°F Air/70°F Water
(91.71 kgs. @ 32.2°C Air/21.1°C water)

(50 cycle produces 83% of above stated production capacities)

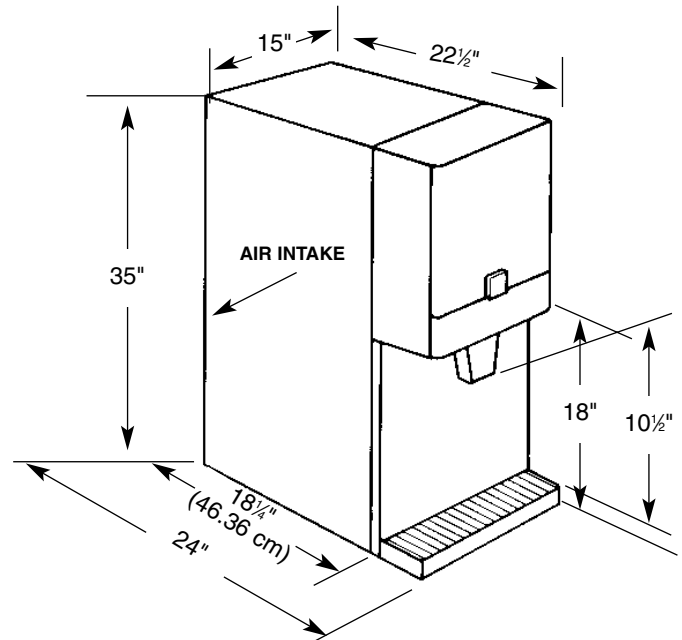

Cabinet Construction: Stainless steel

Dimensions: 15" (38.1 cm) wide, 22 1/2" (57.15 cm) deep, 35" (88.9 cm) high

Shipping Weight: 178 lbs. (81 kgs.)

Agency Listings:



Ice making capacities

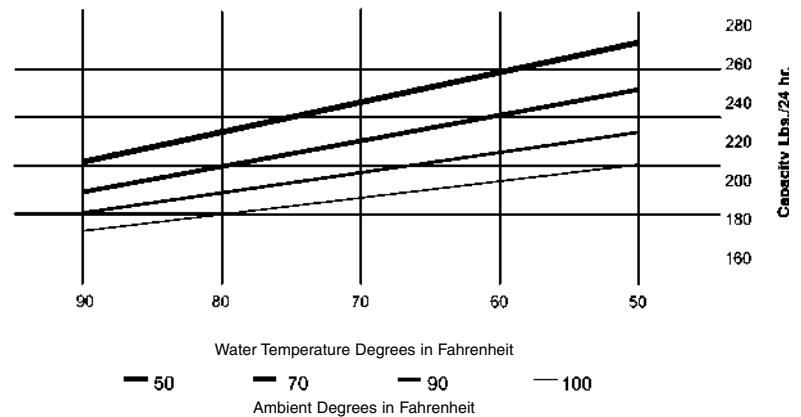

Part Number	Model Number	Dispensing Method	Standard Electrical	Condenser	Production 70°/50° lbs./kgs.
	IMD-300-15ASPB	Push button	115/60/1	Air	246 lbs./112 kgs.
	IMD-302-15ASPB	Push button	220-240/50/1	Air	204 lbs./92 kgs.



For more information or to place an order, contact your sales representative or authorized distributor.

In the US:

Phone: 1-800-238-3600

Fax: 1-800-535-4235

Outside the US:

Phone: 1-763-421-6120

Fax: 1-763-422-3297

IMI Cornelius Inc.

One Cornelius Place
Anoka, MN 55303-6234
USA