

# Impulse™ Juice

**Gulf ICE Systems, Inc.**

## *Post-Mix Non-Carbonated Beverage Dispenser*

- Accepts a variety of merchandising messages
- Designed for performance, reliability, and ease of service



©2006 IMI Cornelius, Inc.  
CV8680-1006

NON-CARBONATED



7790 Sears Blvd. Pensacola, FL 32514  
 P.O. Box 15151

PH: (850) 474-1784  
 FX: (850) 477-2458

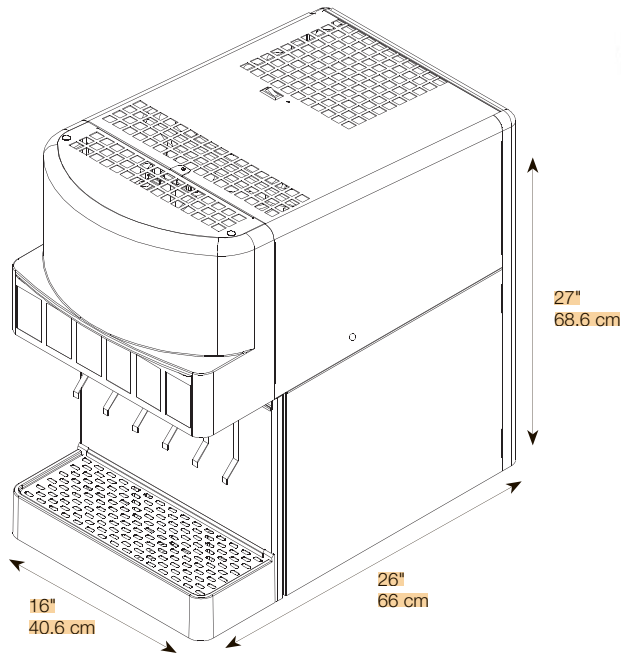

PART NUMBER	DESCRIPTION
851000320	Impulse™ 1 6 Flavor UFJ Lever Activated, 115V / 60Hz
851000359	Impulse™ 1 6 Flavor UFJ Portion Control, 115V / 60Hz
851000366	Impulse™ 1 6 Flavor UFJ Push Button, 115V / 60Hz

### TECHNICAL SPECIFICATIONS:

TYPE OF VALVES . . . . . UFJ 3 oz (88.8 mL) / sec  
 Post-Mix Lever

NUMBER OF VALVES . . . . . 6

REFRIGERANT . . . . . R-134a

ELECTRICAL REQUIREMENTS . . 120 V / 60 Hz

CUP CLEARANCE . . . . . 10.25" (26 cm)

COMPRESSOR . . . . . 1/3 HP

WATER BATH SIZE . . . . . 17 gal (64.4 L)

ICE BANK SIZE . . . . . 30 lb (13.6 kg)

CONTINUOUS  
 DRINK CAPACITY . . . . . 2.5 12 oz (355 mL)  
 drinks/min @ 75°F (24°C)  
 ambient

PEAK DRINK CAPACITY . . . . . 217 12oz (355 mL)  
 drinks/min @ 75°F (24°C)  
 ambient

SHIPPING WEIGHT: . . . . . 124 lb (56 kg)

AGENCY LISTINGS . . . . .



**Gulf ICE Systems, Inc.**

**1-800-322-4853**

