



EV9100-94

S0-24 System

Softening System for espresso applications



S0-24 Espresso System with Softening Cartridge: EV9100-94

S0-204 Softening Cartridge: DEV9105-45

BENEFITS

20" large capacity softening system for espresso machines reduces scale-forming minerals like calcium and magnesium

Reduces scale forming minerals by ion exchange

May be used on water having up to 30 grains per gallon (500 mg/L) hardness

Useful where full size water conditioners are impractical

Includes mounting bracket, pressure relief valve and filter wrench

Recommended to be used in conjunction with an Everpure filtration system

INSTALLATION TIPS

Choose a mounting location suitable to support the full weight of the system when operating

Use 1" water line

Install vertically with bowl hanging down

Allow 2-1/2" clearance below the cartridge for easy cartridge replacement

Flush cartridges by running water through for one minute at full flow

Make sure O-ring on bowl is sufficiently lubricated

Always screw on bowls by hand; Do not use a housing wrench

OPERATION TIPS

Change cartridges on a regular 6 month preventative maintenance program

Change cartridges when hardness of treated water increases to more than 3 gpg

Service flow rate must not exceed 2.0 gpm

Always flush the cartridge at time of installation and cartridge change

To determine cartridge life, divide total capacity of cartridge (4,400 grains) by the hardness in grains per gallon (gpg) or milligrams per liter (ppm), respectively

APPLICATION/SIZING

For commercial espresso, specialty coffee and ice tea machines

4,500 grain softening capacity

Divide cartridge grain capacity by grains per gallon in influent water to calculate total gallons product water

S0-24 System

SPECIFICATIONS

Overall Dimensions:

24"H x 8"W x 7"D

Inlet connection: 1"

Outlet connection: 1"

Service Flow Rate:

Maximum 2.0 gpm (7.6 Lpm)

Pressure Requirements:

10 - 125 psi (0.7 - 8.6 bar), non-shock

Temperature:

35 - 100°F (2 - 38°C)

No electrical connection required

Shipping Weight: 21 lbs.

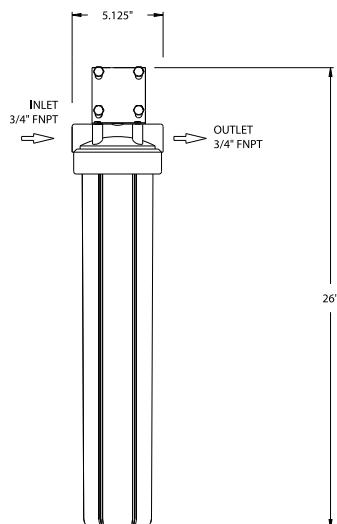

WARRANTY

Everpure water treatment systems (excluding replaceable elements) are covered by a limited warranty against defects in material and workmanship for a period of five years after date of purchase. Everpure replaceable elements (filter cartridges and water treatment cartridges) are covered by a limited warranty against defects in material and workmanship for a period of one year after date of purchase. See printed warranty for details. Everpure will provide a copy of the warranty upon request.



EVERPURE, INC.
2375 Sanders Road
Northbrook, IL 60062
Toll Free (800) 323-7873
Tel (847) 205-6000
Fax (800) 942-0081
<http://www.everpure.com>

In Europe:
N.V. EVERPURE (EUROPE) S.A.
Geldenaaksebaan 478
B-3001 Heverlee
Belgium
Tel 32-16-401191
FAX 32-16-402691

In Japan:
EVERPURE JAPAN, INC.
1-8-19, Tsumada Kita,
1-Chome, Atsugi City
Kanagawa Ken 243-0812
Japan
Tel 81-462-23-6563
FAX 81-462-21-6775

Everpure, Inc.
2375 Sanders Road
Northbrook, IL 60062
Phone: 800-323-7873 Fax: 800-942-0081