



EV9272-00

# QL3-BH System

Delivers premium quality water for coffee applications



QL3-BH System: EV9272-00

BH Replacement Cartridge: EV9612-00

## BENEFITS

Provides clear, fresh, premium quality ingredient water for great tasting coffee and beverages.

Everpure's unique filter blend using activated carbon reduces chlorine taste and odor and other offensive contaminants

Saves energy by reducing scale build-up. Proportioned scale inhibitor feed dramatically prevents limescale from forming in brewers.

Engineered to always feed the correct amount of scale inhibitor into each volume of water

Precoat submicron technology reduces dirt and particles as small as 1/2 micron in size

Reduces health contaminants such as asbestos fibers and Cryptosporidium and Giardia cysts

Increases holding time of coffee

Sanitary cartridge replacement is simple, quick and clean. Internal filter parts are never exposed to handling or contamination

NSF Certified under NSF/ANSI Standards 42 and 53

## INSTALLATION TIPS

Never use saddle valve for connection

Use 1/4" water line

Install vertically with cartridge hanging down

Allow 2-1/2" clearance below the cartridge for easy cartridge replacement

Flush BH cartridge by running water through filter for three minutes at full flow

## OPERATION TIPS

Change cartridges on a regular 6 month preventative maintenance program

Change cartridges when capacity is reached or when pressure falls below 10 psi

Service flow rate must not exceed 0.5 gpm

Always flush the filter cartridge at time of installation and cartridge change

## APPLICATION/SIZING

For coffee service applications

For low flow, medium volume brewers

Capacity: 3,000 gallons (11,350) or 6,000 pots

# QL3-BH System

## SPECIFICATIONS

Overall Dimensions:  
16.5"H x 3.75"W x 3.75"D

Inlet connection: 1/4"

Outlet connection: 1/4"

Service Flow Rate:  
Maximum 0.5 gpm (1.9 Lpm)

Pressure Requirements:  
10 - 125 psi (0.7 - 8.6 bar), non-shock

Temperature:  
35 - 100°F (2 - 38°C)

No electrical connection required

Shipping Weight:  
4 lbs.

Operating Weight:  
7 lbs.

The contaminants or other substances removed or reduced by this drinking water system are not necessarily in your water. Do not use with water that is microbiologically unsafe or of unknown quality without adequate disinfection before or after the system. Systems certified for cyst reduction may be used with disinfected water that may contain filterable cysts.

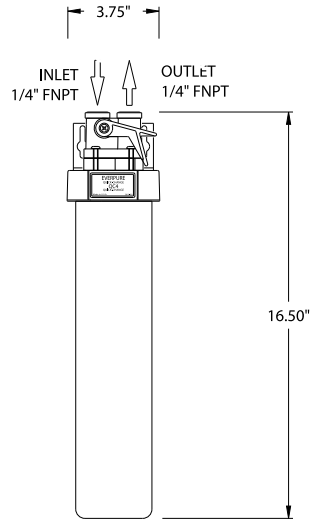

## WARRANTY

Everpure water treatment systems (excluding replaceable elements) are covered by a limited warranty against defects in material and workmanship for a period of five years after date of purchase. Everpure replaceable elements (filter cartridges and water treatment cartridges) are covered by a limited warranty against defects in material and workmanship for a period of one year after date of purchase. See printed warranty for details. Everpure will provide a copy of the warranty upon request.



System Tested and Certified by NSF International against NSF/ANSI Standard 42 and 53 for the reduction of:

Standard No. 42: Aesthetic Effects  
Chemical Unit  
Taste and Odor Reduction  
Chlorine Reduction  
Mechanical Filtration Unit  
Particulate Reduction, Class I:  
99.9+% reduction of particles  
one-half micron and larger in size  
Standard No. 53: Health Effects  
Mechanical Filtration Unit  
Turbidity Reduction  
Cyst Reduction  
Asbestos Reduction

### EVERPURE®

EVERPURE, INC.  
2375 Sanders Road  
Northbrook, IL 60062  
Toll Free (800) 323-7873  
Tel (847) 205-6000  
Fax (800) 942-0081  
<http://www.everpure.com>

*In Europe:*  
N.V. EVERPURE (EUROPE) S.A.  
Geldenaaksebaan 478  
B-3001 Heverlee  
Belgium  
Tel 32-16-401191  
FAX 32-16-402691

*In Japan:*  
EVERPURE JAPAN, INC.  
1-8-19, Tsumada Kita,  
1-Chome, Atsugi City  
Kanagawa Ken 243-0812  
Japan  
Tel 81-462-23-6563  
FAX 81-462-21-6775

Everpure, Inc.  
2375 Sanders Road  
Northbrook, IL 60062  
Phone: 800-323-7873 Fax: 800-942-0081