



EV9272-22

QC71 Twin Parallel Head

Filter head exclusively for Everpure replacement cartridges

BENEFITS

New redesigned commercial quality filter head for Everpure filter cartridges

Dual filter head is parallel plumbed

Built-in water shut off valve and flushing valve makes cartridge change outs easy

A cartridge nesting feature provides a more secure and durable fit

Includes mounting box bracket and screws for fast and easy installation. No extra mounting plate is required

Built-in water pressure gauge helps monitor proper flow

New modular design of box bracket allows for future retrofitting of add-on components without disassembly of system. Optional wing bracket kits available

All wetted parts have passed NSF extraction tests

Engineered for durability, strength and longevity. Will not corrode

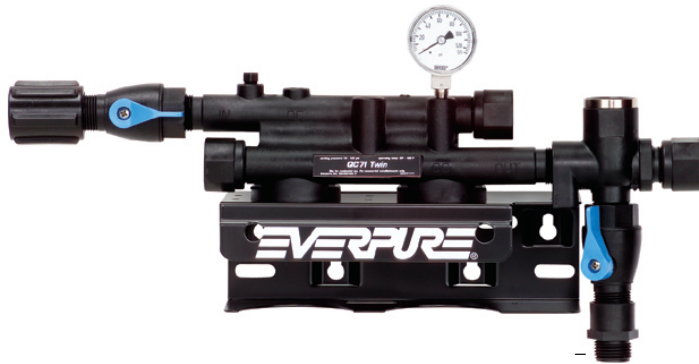

QC71 Twin Parallel Head:
EV9272-22

INSTALLATION TIPS

Mounts directly onto flat surface

Install vertically so cartridge hangs down

Allow 2-1/2" clearance below the cartridge for easy cartridge replacement

Flush filter by running water through filter according to cartridge instructions

OPERATION TIPS

Change cartridges on a regular 6 month preventative maintenance program

Change cartridges when capacity is reached or when pressure decreases

Always flush the filter cartridge at time of installation and cartridge change

APPLICATION/SIZING

For foodservice applications

Capacity: varies according to filter cartridge used



QC71 Twin Parallel Head

SPECIFICATIONS

Overall Dimensions: 8.5"H x 16.6"W x 5.5"D

Inlet connection: 3/4"

Outlet connection: 3/4"

No electrical connection required

Shipping Weight: 2 lbs.

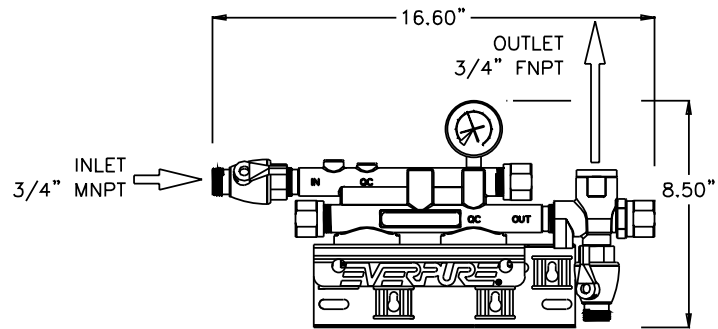

WARRANTY

Everpure water treatment systems (excluding replaceable elements) are covered by a limited warranty against defects in material and workmanship for a period of five years after date of purchase. Everpure replaceable elements (filter cartridges and water treatment cartridges) are covered by a limited warranty against defects in material and workmanship for a period of one year after date of purchase. See printed warranty for details. Everpure will provide a copy of the warranty upon request.



EVERPURE, INC.
2375 Sanders Road
Northbrook, IL 60062
Toll Free (800) 323-7873
Tel (847) 205-6000
Fax (800) 942-0081
<http://www.everpure.com>

In Europe:
N.V. EVERPURE (EUROPE) S.A.
Geldenaaksebaan 478
B-3001 Heverlee
Belgium
Tel 32-16-401191
FAX 32-16-402691

In Japan:
EVERPURE JAPAN, INC.
1-8-19, Tsumada Kita,
1-Chome, Atsugi City
Kanagawa Ken 243-0812
Japan
Tel 81-462-23-6563
FAX 81-462-21-6775

Everpure, Inc.
2375 Sanders Road
Northbrook, IL 60062
Phone: 800-323-7873 Fax: 800-942-0081