



EV9324-02

Insurice Twin-I 2000 System

Delivers premium quality water for ice applications



Insurice Twin-I 2000 System: EV9324-01

I 2000 Replacement Cartridge: EV9612-21

BENEFITS

- Reduces ice machine problems caused by scale build-up from dirt and dissolved minerals
- Reduces chlorine taste and odor and other offensive contaminants
- Self-contained scale inhibitor feed keeps ice machines functioning at full capacity
- Reduces maintenance and service costs by reducing scale and clogging of distribution lines, evaporator plate and pump
- Precoat submicron technology reduces dirt and particles as small as 1/2 micron in size
- Reduces health contaminants such as asbestos fibers and Cryptosporidium and Giardia cysts
- Manifold features water shut off, flushing valve and outlet pressure gauge
- Sanitary cartridge replacement is simple, quick and clean. Internal filter parts are never exposed to handling or contamination
- NSF Certified under NSF/ANSI Standards 42 and 53

INSTALLATION TIPS

- Choose a mounting location suitable to support the full weight of the system when operating
- Never use saddle valve for connection
- Use 3/4" water line
- Do not connect system to water-cooled condenser
- Install vertically with cartridges hanging down and allow 2-1/2" clearance below the cartridge for easy cartridge replacement
- Flush cartridges by running water through system for five minutes at full flow

OPERATION TIPS

- Change cartridges on a regular 6 month preventative maintenance program
- Change cartridges when capacity is reached or when pressure falls below 10 psi
- Service flow rate must not exceed 3.34 gpm
- Always flush the filter cartridge at time of installation and cartridge change

APPLICATION/SIZING

- For ice machine applications
- Most cubers up to 1,450 lbs./day
- Most flakers up to 2,200 lbs./day

Insurice Twin-I 2000 System

SPECIFICATIONS

Overall Dimensions:
25.26"H x 16.6"W x 5.5"D

Inlet connection: 3/4"

Outlet connection: 3/4"

Service Flow Rate:
Maximum 3.34 gpm (12.6 Lpm)

Pressure Requirements:
10 - 125 psi (0.7 - 8.6 bar), non-shock

Temperature: 35 - 100°F (2 - 38°C)

No electrical connection required

Shipping Weight: 12 lbs.

Operating Weight: 18 lbs.

The contaminants or other substances removed or reduced by this drinking water system are not necessarily in your water. Do not use with water that is microbiologically unsafe or of unknown quality without adequate disinfection before or after the system. Systems certified for cyst reduction may be used with disinfected water that may contain filterable cysts.

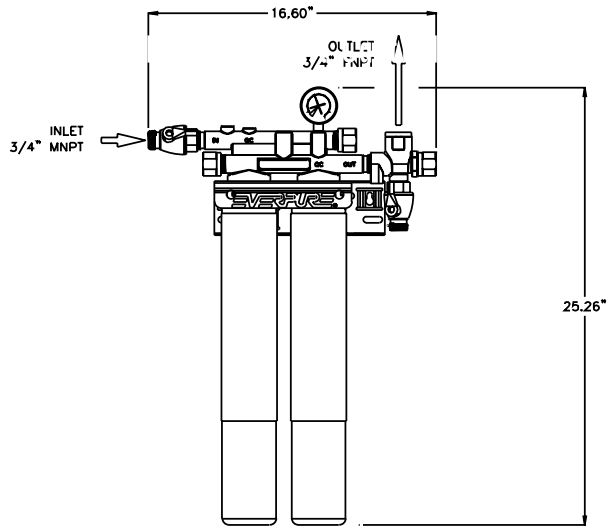

WARRANTY

Everpure water treatment systems (excluding replaceable elements) are covered by a limited warranty against defects in material and workmanship for a period of five years after date of purchase. Everpure replaceable elements (filter cartridges and water treatment cartridges) are covered by a limited warranty against defects in material and workmanship for a period of one year after date of purchase. See printed warranty for details. Everpure will provide a copy of the warranty upon request.



System Tested and Certified by NSF International against NSF/ANSI Standard 42 and 53 for the reduction of:

Standard No. 42: Aesthetic Effects
Chemical Unit
Taste and Odor Reduction
Chlorine Reduction
Mechanical Filtration Unit
Particulate Reduction, Class I:
99.9+% reduction of particles
one-half micron and larger in size
Standard No. 53: Health Effects
Mechanical Filtration Unit
Turbidity Reduction
Cyst Reduction
Asbestos Reduction



EVERPURE, INC.
2375 Sanders Road
Northbrook, IL 60062
Toll Free (800) 323-7873
Tel (847) 205-6000
Fax (800) 942-0081
<http://www.everpure.com>

In Europe:
N.V. EVERPURE (EUROPE) S.A.
Geldenaaksebaan 478
B-3001 Heverlee
Belgium
Tel 32-16-401191
FAX 32-16-402691

In Japan:
EVERPURE JAPAN, INC.
1-8-19, Tsumada Kita,
1-Chome, Atsugi City
Kanagawa Ken 243-0812
Japan
Tel 81-462-23-6563
FAX 81-462-21-6775

Everpure, Inc.
2375 Sanders Road
Northbrook, IL 60062
Phone: 800-323-7873 Fax: 800-942-0081