



## 1722 SIDEWINDER POST-MIX DROP IN DISPENSER



### FEATURES

**Large ice capacity** - Ice chest has 85 lb capacity

**Adjustable** - Standard UFB-1™ fast flow valves

**Insulated** - Foamed polyurethane insulation

**Secure** - Key lock switch conveniently located on tower

**Durable** - All stainless steel construction

**Functionality** - Extra wide built in drain pan on the dispensing pan

**Ease of use** - Removable front and back panels on the dispensing tower

**Speed** - Rated at six 12oz drinks per minute

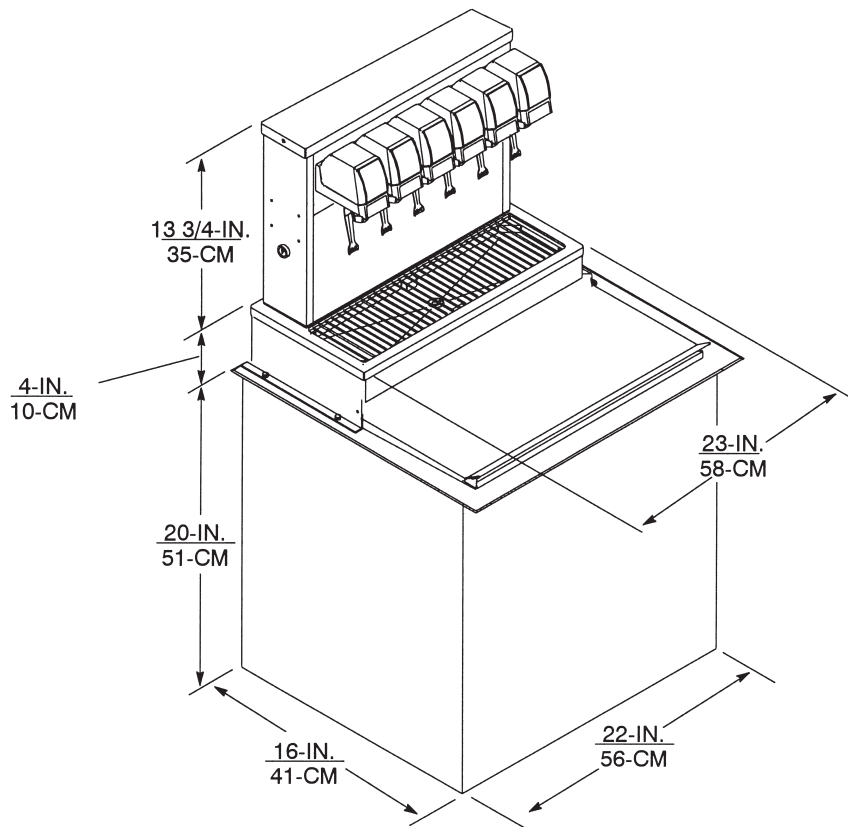

PART NUMBER	DESCRIPTION
631100047	1722 Drop-in dispenser with Universal Tower and 6 UFB-1™ 2-4 oz sanitary lever valves
630001220	Cabinet stand for 1722 drop-in dispenser, assembled
630001212	Cabinet stand for 1722 drop-in dispenser, not assembled

## TECHNICAL SPECIFICATIONS

TYPE OF VALVES . . . . . UFB-1™ post-mix

NUMBER OF VALVES: . . . . . 6

CUP CLEARANCE . . . . . 9.75" (248 mm)

COUNTER TOP CUT OUT . . . . . 22.25" x 16.25"  
(565 mm x 413 mm)

ICE STORAGE CAPACITY . . . . . 85 lb (35.6 kg)

DRAIN SIZE . . . . . 0.75" (19.11 mm)  
flexible hose

CONNECTION . . . . . Water: 0.375" (9.5 mm)  
barb fitting  
Syrup: 0.375" (9.5 mm)  
barb fitting

ELECTRICAL REQUIREMENTS . . 120 V / 60 Hz / 1.5 Amps

SHIPPING WEIGHT . . . . . 155 lb (70 kg)

AGENCY LISTINGS . . . . .

