



QUANTUM™ 3000

Three-Flavor, Post-Mix Juice Dispenser



FEATURES

- Three product selection
- Easy front loading of concentrate
- High performance peristaltic pumps and a unique mixing valve assure elimination of stratification
- Large concentrate capacity
- Tamper resistant and disposable packaging
- Modular component design provides ease of sanitation and service
- New contemporary cabinet design is a blend of attractive black plastic and sturdy stainless steel
- Easy-to-adjust brining system controls and maintains a consistent finished drink
- Lighted merchandiser is standard
- Push button or programmable portion controlled dispensing available

CATF 8637-01

J U I C E D I S P E N S E R



SPECIFICATIONS

DESCRIPTION

Model SLJ1400-3

- 115 volts, 60 Hz, 9.43 amps
- 220 volts, 50 Hz, 5 amps

REFRIGERATION

- 1/3 H.P. hermetically sealed system
- R-134a refrigerant 6.25 oz. (177 g)

CABINETRY

Plastic and stainless steel

DISPENSER DIMENSIONS

Height (with 4" legs)34½" (87.62 cm)
 Width14¾" (37.50 cm)
 Depth27¼" (69.15 cm)

WEIGHT

Dry weight129 lbs. (58.56 kg)
 Shipping weight145 lbs. (65.83 kg)
 Maximum counter weight161 lbs. (73.09 kg)

RECOMMENDED CLEARANCE

2" (5.08 cm) in back for air circulation

WATER CONNECTION

3/8" (.95 cm) SAE male flare fitting on dispenser

CONCENTRATE STORAGE

640 oz. (18.9 L)

WATER SUPPLY REQUIREMENTS

- 100 psi (7 kg/sq. cm) maximum static pressure
- 20 psi (1.4 kg/sq. cm) minimum dynamic pressure

COOLING CAPACITY

Continuous 5 oz. (147.85 ml) drinks at 4 per minute with 75°F (24°C) concentrate without exceeding 45°F (7°C) drink temperature

FLOW RATE

Adjustable water flow rate from 1.6 oz./sec. (47.31 ml/sec.) to 2.2 oz./sec. (65.05 ml/sec.); handles 2 + 1 through 7 + 1 concentrate

OPTIONAL ACCESSORIES

- Illuminated merchandiser
- Electric hospital hose
- Portion control
- Sanitizing tank kit
- Dispense key lock
- Extended splash panel kit (lowers drink tray)

AGENCY LISTINGS

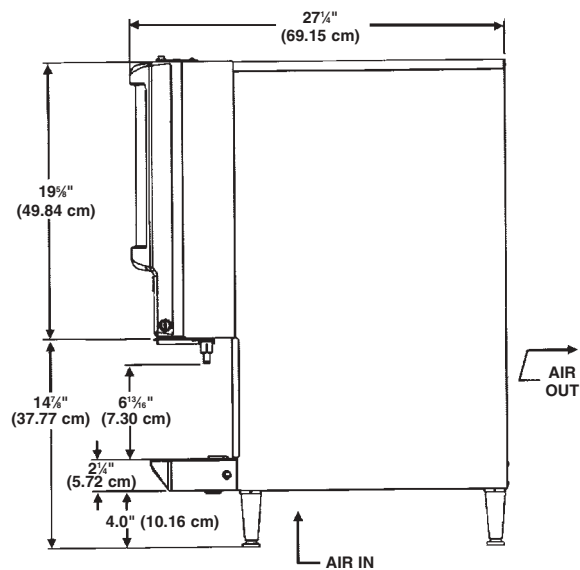
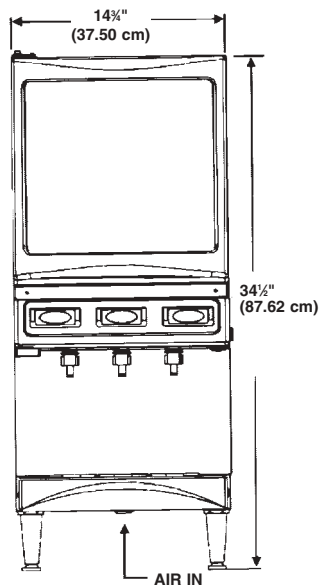

For more information or to place an order, contact your sales representative or authorized distributor.

In the US:
 Phone: 1-800-238-3600
 Fax: 1-800-535-4235
Outside the US:
 Phone: 1-763-421-6120
 Fax: 1-763-422-3297

IMI Cornelius Inc.
 One Cornelius Place
 Anoka, MN 55303-6234
 USA