



## TEA TOWER

POST-MIX BEVERAGE DISPENSER



### FEATURES

- Variety** - One or two flavor capability, UFB-1™ valves
- Easy access** - Inlet line access from back or bottom of tower
- Options** - Drip tray can be removable or plumbed
- Flexible** - Cooling capacity relies on your choice of remote cooling unit
- Compact** - Syrup is stored in remote containers
- Simple** - Simple connections to water and syrup lines
- Durable** - Stainless steel construction
- Adjustable** - Brix ratio adjustable from 4:1 to 6:1

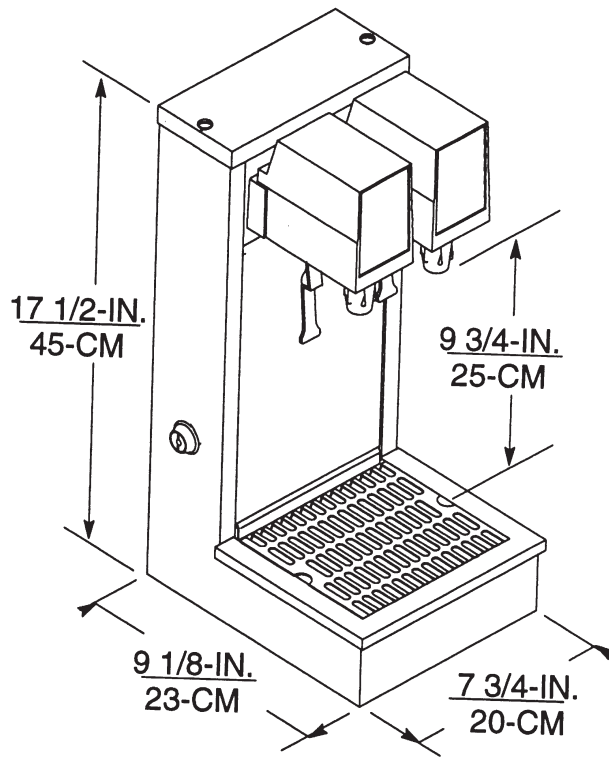

PART NUMBER	DESCRIPTION
620048544	Two flavor, UFB-1™ Sanitary Lever Valves
631000014	Single flavor, UFB-1™ Sanitary Lever Valves

## TECHNICAL SPECIFICATIONS

CUP CLEARANCE . . . . . 9.75" (248 mm)  
 WATER PRESSURE REQUIRED . . . 30 lb psi minimum  
 ELECTRICAL REQUIREMENTS . . . 120 V / 60 Hz / 2 Amps

SHIPPING WEIGHTS . . . . . 620048544 and  
 631000014: 13 lb

AGENCY LISTINGS: . . . . .  

