





772

PRODUCT SPECIFICATIONS



Capacity

Electric Frequency	60 Hz			50 Hz			
	Dispenser Type	Air-Cooled	Remote	Water-Cooled	Air-Cooled	Remote	Water-Cooled
Barrel Volume ^{II}	176 oz	176 oz	176 oz	5,205 mL	5,205 mL	5,205 mL	
Continuous Draw - Single Barrel [§]	-	-	-	92,269 mL/hr	-	-	
Continuous Draw - Alternating Barrels [§]	4,500 oz/hr	5,020 oz/hr	4,850 oz/hr	115,337 mL/hr	124,209 mL/hr	-	
Recovery Time [§]	4 mins	3 mins	3 mins	4 mins	3 mins	-	
Refrigeration	15,000 BTU/hr (15,826 kJ/hr), R-404A/R-448A [†]	19,000 BTU/hr (20,046 kJ/hr), R-404A/R-448A [†]					
Agency	NSF 18  UL/CSA 60335-1 			Complies with IEC/EN 60335-1; IEC/EN 60335-2-75; IEC/EN 60335-2-89; IEC/EN 61000-3-2; IEC/EN 61000-3-3; CISPR 14-1; CISPR 14-2.			
	Complies with UL 60335-1; UL 60335-2-89; IEC 60335-2-75.						

[§] Testing completed at 75°F (24°C).

^{II} Volume varies based on barrel faceplate.

[†] R-404A and R-448A refrigeration systems are functionally equivalent.

Electrical Requirements[‡]

Electric Frequency	60 Hz	50 Hz
Voltage	215 - 245 VAC ^Δ , Single Phase	215 - 245 VAC ^Δ , Single Phase
Current/Power	20 Amps	3,000 W
Receptacle	NEMA #L6-20R, 3 Wire	Varies depending on market.
Beater Motor	(2) 1/6 HP, 0.85 A	(2) 1/6 HP, 0.81 A
Fan Motor	(1) 1/4 HP, 0.83 A	(1) 1/6 HP, 0.60 A

[‡] General requirements only. Always check dispenser nameplate label for specific rating information. ^Δ Buck-boost transformer or AVR required for operation outside this range.



Frozen Beverage Dispensers
EVERYONE LOVES FROZEN®

772

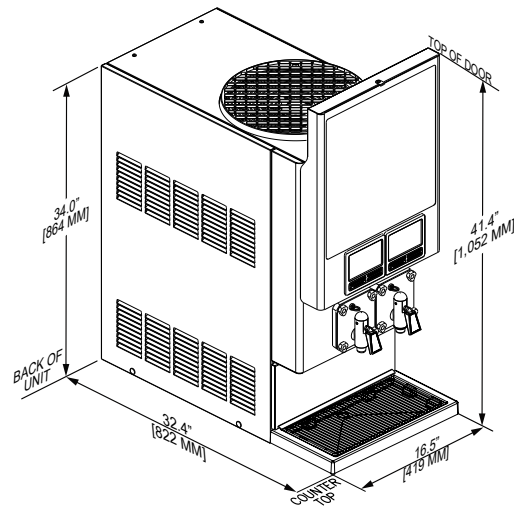
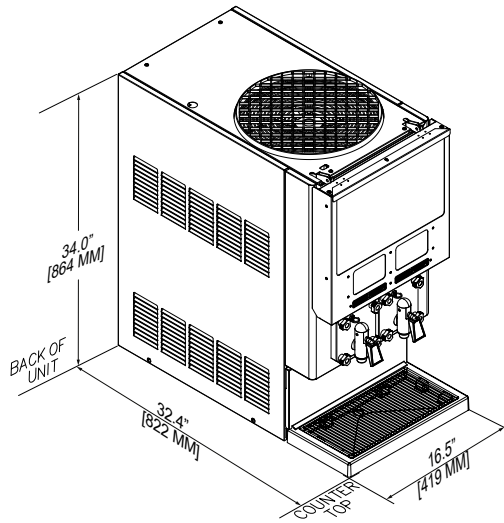

Weights & Dimensions

Measuring System	Imperial			Metric		
	Short Door	Tall Door	Video Door	Short Door	Tall Door	Video Door
Door Model	Short Door	Tall Door	Video Door	Short Door	Tall Door	Video Door
Height	34.0 in	41.4 in	43.54 in	864 mm	1,052 mm	1,106 mm
Width	17.0 in			432 mm		
Depth	32.5 in			826 mm		
Back/Side Clearance (Min.)	3 in			76 mm		
Top Clearance (Min.)	12 - 36 in*			304 - 914 mm*		
Duratrans	10 in x 16 3/4 in	17 3/4 in x 16 3/4 in		254 mm x 425 mm	451 mm x 425 mm	
Flavor Card	4 7/8 in x 3 1/2 in			124 mm x 89 mm		
Dispenser Type	Air-Cooled	Remote	Water-Cooled	Air-Cooled	Remote	Water-Cooled
Empty Weight	298 lbs	283 lbs	295 lbs	135 kg	128 kg	134 kg
Operating Weight	321 lbs	306 lbs	318 lbs	146 kg	139 kg	144 kg

* 12 in (304 mm) with side or back open-air conditions, 36 in (914 mm) in equipment alcove.

Water, CO₂ and Syrup Requirements

Measuring System	Imperial	Metric
Water System Input	3/8" Supply Line, 30 PSIG Flowing (minimum)	3/8" Supply Line, 207 kPag Flowing (minimum)
CO ₂ System Input	70 - 72 PSIG (maximum)	483 - 496 kPag (maximum)
Condenser Water Inlet Flow Rate ^o	1 - 3 gal / min	3.8 - 11.4 L/min
Condenser Water Inlet Temperature ^o	40 - 90° F	4.4 - 32° C
Syrup	Input: 70 - 72 PSIG (483 - 496 kPag)	
	Bag-In-Box (BIB) Connections, (2) Base Syrups	

^o For water-cooled dispensers.