



CARBONATOR

LOW PROFILE LARGE RESERVE



FEATURES

Large reserve - 2.5 gallon carbonated water reserve tank

Low profile - Low voltage, solid state, liquid level control

Intelligent - Check valve protects against water entering CO₂ supply system and double ball check protects against carbonated water backing up into water supply

Durable - Thermal protector on pump minimizes pump burn out due to lack of water

Quiet - Rubber feet for quiet operation

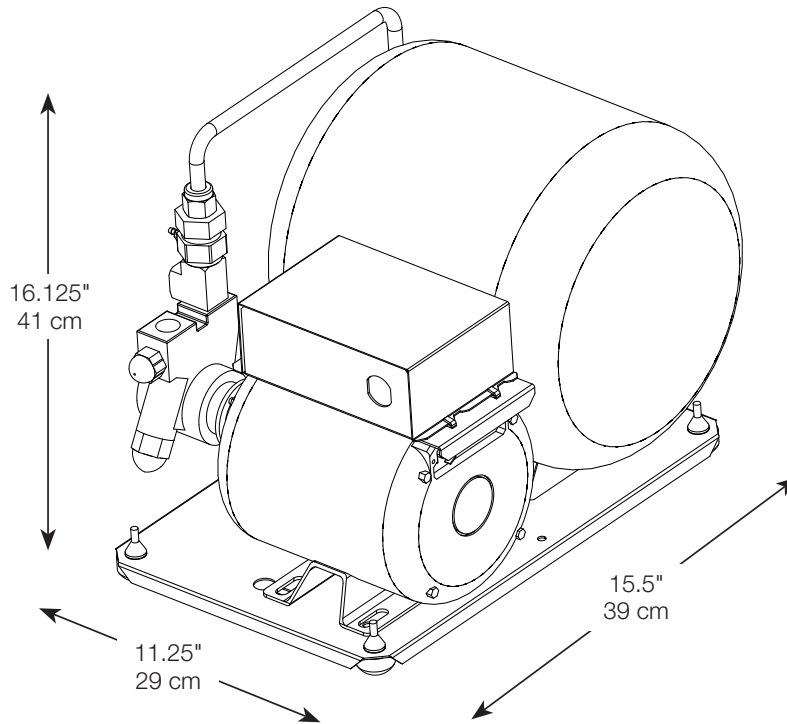

PART NUMBER	DESCRIPTION
416424000	Low Profile Large Reserve Carbonator, 115 V / 50 Hz, 60 Hz with ASSE 1022 vent to atmosphere check valve
496424000	Low Profile Large Reserve Carbonator 220 / 50 Hz, 230 V / 60 Hz without vent to atmosphere check valve

TECHNICAL SPECIFICATIONS:

DIMENSIONS 16.125"H (41 cm) x
 15.5"W (39 cm) x
 11.25"D (29 cm)

SHIPPING WEIGHT 30 lb (14 kg)

CARBONATOR MOTOR 1/3 HP

CARBONATOR PUMP 100 GPH

OPERATING PRESSURE 125 psi maximum

INLET CONNECTIONS 0.375"

SODA WATER OUTLET
 CONNECTIONS (2) 0.375" (9.525 mm)

ELECTRICAL REQUIREMENTS . . 115 V / 50 Hz,
 60 Hz / 7.2 Amps
 220V / 50 Hz
 230 V / 60 Hz / 3.6 Amps

AGENCY LISTINGS   

