



# EVERPURE® INSURICE® QUAD - i4000<sup>2</sup> SYSTEM

DELIVERS PREMIUM QUALITY WATER FOR ICE APPLICATIONS

Insurice Quad-i4000<sup>2</sup> System: EV9325-04  
i4000<sup>2</sup> Replacement Cartridge: EV9612-32



## APPLICATIONS

Ice machine  
Higher volume, higher flow and higher capacity ice machines

## FEATURES • BENEFITS

Proprietary Micro-Pure® II filtration media effectively inhibits the growth of bacteria on the filter media that can decrease product life

Self-contained scale inhibitor feed keeps ice machines functioning at full capacity\*

Manifold features water shut-off, flushing valve and outlet pressure gauge

Reduces ice machine problems caused by scale buildup from dirt and dissolved minerals\*

Reduces chlorine taste and odor and other offensive contaminants

Reduces maintenance and service costs by reducing scale\* and clogging of distribution lines, evaporator plate and pump

Exclusive precoat filtration provides superior chlorine taste and odor reduction and micro-filters dirt and particles as small as 0.5 micron in size by mechanical means

NSF/ANSI Standard 53 certified to reduce cysts such as *Cryptosporidium* and *Giardia* by mechanical means

Sanitary cartridge replacement is simple, quick and clean

\*As tested by Pentair® Everpure

## INSTALLATION TIPS

Choose a mounting location suitable to support the full weight of the system when operating

Never use saddle valve for connection

Use 3/4" water line

Do not connect system to water-cooled condenser

Install vertically with cartridges hanging down and allow 2-1/2" (6.35 cm) clearance below the cartridge for easy cartridge replacement

Flush cartridges by running water through system for five (5) minutes at full flow

## OPERATION TIPS

Change cartridges on a regular six (6) month preventative maintenance program

Change cartridges when capacity is reached or when pressure falls below 10 psi (0.7 bar)

Service flow rate must not exceed 6.7 gpm (25.3 Lpm)

Always flush the filter cartridge at time of installation and cartridge change

## SIZING

Service Flow Rate: Maximum  
6.68 gpm (25.3 Lpm)

# EVERPURE® INSURICE® QUAD - i4000<sup>2</sup> SYSTEM

## EV9325-04

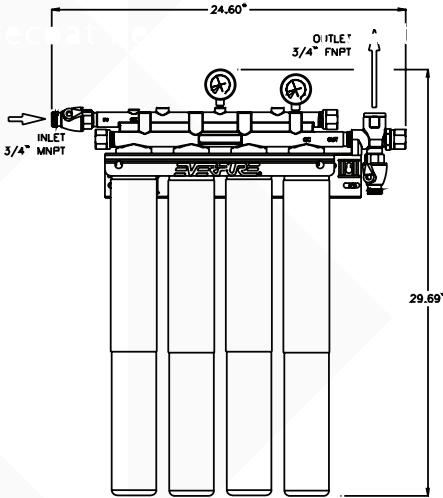

### SPECIFICATIONS

#### Overall Dimensions

29.69" H x 24.6" W x 5.5" D  
(75.4 x 62.4 x 13.9 cm)

#### Inlet Connection 3/4"

#### Outlet Connection 3/4"

#### Service Flow Rate

Maximum 6.68 gpm (25.3 Lpm)

#### Pressure Requirements

10 – 125 psi (0.7 – 8.6 bar), non-shock

#### Temperature

35 – 100°F (2 – 38°C)

#### Electrical Connection

None

#### Shipping Weight

22 lbs. (9.9 kg)

#### Operating Weight

36 lbs. (116.3 kg)



System Tested and Certified by NSF International against NSF/ANSI Standard 42 and 53 for the reduction of:

Standard No. 42 Aesthetic Effects  
Chemical Unit  
Taste and Odor Reduction  
Chlorine Reduction  
Mechanical Filtration Unit  
Nominal Particulate Reduction,  
Class I  
Standard No. 53: Health Effects  
Mechanical Filtration Unit  
Cyst Reduction

EPA No. 002623-IL-002

The contaminants or other substances removed or reduced by this drinking water system are not necessarily in your water. Do not use with water that is microbiologically unsafe or of unknown quality without adequate disinfection before or after the system. Systems certified for cyst reduction may be used with disinfected water that may contain filterable cysts.

### WARRANTY

Everpure water treatment systems by Pentair® (excluding replaceable elements) are covered by a limited warranty against defects in material and workmanship for a period of five years after date of purchase. Everpure replaceable elements (filter cartridges and water treatment cartridges) are covered by a limited warranty against defects in material and workmanship for a period of one year after date of purchase. See printed warranty for details. Pentair will provide a copy of the warranty upon request.



#### FILTRATION & PROCESSING SOLUTIONS

EVERPURE-SHURFLO WORLD HEADQUARTERS, 1040 MUIRFIELD DRIVE, HANOVER PARK, IL 60133 USA • WWW.EVERPURE.COM  
800.942.1153 MAIN (US ONLY) • 630.307.3000 MAIN • 630.307.3030 FAX • CSEVERPURE@PENTAIR.COM EMAIL

EVERPURE-SHURFLO AUSTRALIA / NEW ZEALAND, 1-21 MONASH DRIVE, DANDENONG SOUTH, VIC, 3175, AUSTRALIA  
1300.576.190 TEL • AU.EVERPURE@PENTAIR.COM EMAIL

EVERPURE-SHURFLO CHINA, 21F CLOUD 9 PLAZA, NO 1118, SHANGHAI, 200052, CHINA  
86.21.3211.4588 TEL • 86.21.3211.4580 FAX • CHINA.WATER@PENTAIR.COM EMAIL

EVERPURE-SHURFLO INDIA, GREEN BOULEVARD, B-9/A, 7TH FLOOR - TOWER B SECTOR 62, NOIDA - 201301  
91.120.419.9444 TEL • 91.120.419.9400 FAX • INDIACUSTOMER@PENTAIR.COM EMAIL

EVERPURE-SHURFLO EUROPE, PENTAIR WATER BELGIUM BVBA, INDUSTRIEPARK WOLFSTEE, TOEKOMSTLAAN, 30 B-2200 HERENTALS, BELGIUM  
+32.(0).14.283.500 TEL • +32.(0).14.283.505 FAX • SALES@EVERPURE-EUROPE.COM EMAIL

EVERPURE-SHURFLO JAPAN INC., HASHIMOTO MN BLDG. 7F, 3-25-1 HASHIMOTO, MIDORI-KU, SAGAMIHARA-SHI KANAGAWA 252-0143, JAPAN  
81.(0)42.775.3011 TEL • 81.(0)42.775.3015 FAX • INFO@EVERPURE.CO.JP EMAIL

EVERPURE-SHURFLO SOUTHEAST ASIA, 390 HAVELOCK ROAD, #04-01, KING'S CENTRE, SINGAPORE 169662  
65.6795.2213 TEL • FAX: 65.6795.2219 FAX • CSEVERPURE@PENTAIR.COM EMAIL

All Pentair trademarks and logos are owned by Pentair, Inc. All other brand or product names are trademarks or registered marks of their respective owners. Because we are continuously improving our products and services, Pentair reserves the right to change specifications without prior notice. Pentair is an equal opportunity employer.