

Ice-O-Matic

Ice. Pure and Simple™

Installation and Service Manual GEM-MFI-HEM Series



REFRIGERANT CHANGES

In compliance with EPA regulations requiring the transition away from R-404A refrigerant, effective January 1, 2026, we are updating the refrigerants used in our units to more environmentally sustainable options. Larger remote units will utilize R449A refrigerant, while self-contained units will operate with R-290 refrigerant. Identification of these units will be facilitated through multiple indicators: the final two digits of the model number (as referenced on the preceding page), the data tag, and stickers affixed to line-sets. Additionally, R-290 units will feature specific warning labels as detailed below.

R449 refrigerant possesses characteristics closely resembling those of R-404A, requiring minimal modifications to existing units aside from a TXV replacement.

In contrast, R-290 exhibits distinct properties that necessitate different considerations.

What is R290?

R-290 is Propane

- Extremely Pure
- Highly Flammable
- **NO ADDED ODORANT** (no smell)
- Heavier than air (pools up in low areas)

R290 SAFETY HAZARDS

Fire/Explosion



Asphyxiation

- You cannot get enough air to breath – there's not enough oxygen
- R404 and R449 are also asphyxiants



How To Use This Manual

Ice-O-Matic provides this manual as an aid to the end user and service technician in installation and maintenance of the **GEM-MFI-HEM Series** ice machines. Do not attempt to perform installation, start-up or maintenance unless you have read and fully understand this manual.

If, at any time, you encounter conditions that are not addressed in this manual, call, E-mail or write the Ice-O-Matic Service Department:

Ice-O-Matic
11100 E. 45th Ave.
Denver, Co. 80239
Attn: Technical Service Department
E-Mail: Tech.support@iceomatic.com

Telephone Numbers
800-423-3367 All Departments

Any Service communication must include:

- Model Number
- Serial number
- A detailed explanation of the problem

Keep this manual for future reference.

The GEM-MFI-HEM Series Service Parts Manual is available separately.

Ice-O-Matic icemakers and dispensers are not approved for outdoor installation.

WARNING: Always disconnect electrical power and shut off water supply whenever maintenance or repairs are performed on the ice machine and related equipment.

CAUTION: Always wear protective eyewear whenever maintenance or repairs are performed on the ice machine and related equipment



AMERICAN FORESTS

Plant-a-Tree Program

As part of our commitment to the global environment, Ice-O-Matic is devoted to sustainability in every aspect of our business. To offset the carbon footprint of our factory in Denver, we not only recycle materials in our packaging and manufacturing but also recycle our industrial and office waste products.

More important, we partner with AMERICAN FORESTS and plant a tree for every ice machine we sell, thereby supporting reforestation of key regions throughout the world. Our goal is to plant 150,000 trees through our Global Sustainability program. Trees reduce topsoil erosion, prevent harmful land pollutants from getting into our waterways and replace air pollutants with fresh, clean oxygen.



Energy Efficiency

Ice-O-Matic is consistently working to improve the energy efficiency of our ice machines. We are uncompromising in our pursuit of both productivity and energy efficiency and are continually looking for ways to improve both, thereby delivering the best value in energy efficient

Ice-O-Matic Warranty

Every Ice-O-Matic ice maker is backed by a warranty that provides both parts and labor coverage. To view the warranty details, register products, or check your warranty status visit the “Warranty and Water Filter Registration” page on www.iceomatic.com

Table of Contents

Introduction	Page i
Table Of Contents	Page ii
Freight Claim Procedure	Page iii
Warranty	Page iv
For The Installer (Guidelines)	Page 1
For The Installer (Applications)	Page 4
For The Installer (Location)	Page 6
Remote Condenser	Page 7
For The Plumber	Page 12
For The Electrician	Page 14
For The Installer (Completed Remote Installation)	Page 16
For The Installer (Check List)	Page 17
Start Up	Page 19
Component Description	Page 20
Electrical Sequence	Page 24
Operation: Water	Page 25
Operation: Refrigeration (Remote)	Page 26
Operation: Performance	Page 29
Sanitizing and Cleaning	Page 31
Remote Condenser Maintenance	Page 32
Air Cooled Maintenance	Page 33
Bearing Maintenance	Page 34
Sensor Maintenance	Page 35
Auger Maintenance	Page 36
Service Diagnosis	Page 37
Control System Diagnostics	Page 39
Removal and Replacement: Water Reservoir and Bin Controls	Page 40
Removal and Replacement: Bearing and Breaker	Page 41
Removal and Replacement: Auger	Page 42
Removal and Replacement: Water Seal	Page 43
Removal and Replacement: Evaporator	Page 44
Removal and Replacement: Gear Motor	Page 45
Removal and Replacement: Fan Blade and Fan Motor	Page 46
Refrigeration System Service	Page 48
Wiring Diagrams	Page 50
Service History	Page 62

Important!**Inspect Promptly**

This merchandise has been carefully inspected and packed in accordance with the carrier's packing specifications. Responsibility for safe delivery has been assumed by the carrier. If loss or damage occurs, you as the consignee must file a claim with the carrier and hold the container for carrier's inspection.

Visible Loss or Damage

Any external evidence of loss or damage must be fully described and noted on your freight bill or express receipt and signed by the carrier's agent. Claims should be filed on a form available from the carrier.

Concealed Loss or Damage

If loss or damage does not appear until merchandise has been unpacked, make a written request for inspection by the carrier within 15 days of the delivery date. Then file a claim on a form from the carrier.

File Claim Without Delay Do Not Return Damaged Merchandise to Ice-O-Matic

Ice-O-Matic Warranty

Every Ice-O-Matic ice maker is backed by a warranty that provides both parts and labor coverage. To view the warranty details, register products, or check your warranty status visit the “Warranty and Water Filter Registration” page on www.iceomatic.com

Installation Guidelines:

For proper operation of the Ice-O-Matic ice machine, the following installation guidelines must be followed. Failure to do so may result in loss of production capacity, premature part failures, and may void all warranties.

Ambient Operating Temperatures: (Not including remote condenser)

Minimum Operating Temperature: 50°F (10°C)

Maximum Operating Temperature 100°F (38°C)

Note: Ice-O-Matic ice makers and dispensers are not approved for outdoor installation.

Incoming Water Supply

Minimum incoming water temperature: 40°F (4.5°C)

Maximum incoming water temperature: 100°F (38°C)

Minimum incoming water pressure: 20 psi (1.4 bar)

Maximum incoming water pressure: 60 psi (4.1 bar)

Note: If water pressure exceeds 60 psi a water pressure regulator must be installed.

Drains

All drain lines must be installed per local codes. Flexible tubing is not recommended. Route bin drain, vented float overflow drain and water condenser drain individually to a floor drain. The use of condensate pumps for draining water is not recommended by Ice-O-Matic. Cold water drains should be insulated to prevent condensation from forming. Ice-O-Matic assumes no responsibility for improperly installed equipment.

Water Filtration

A water filter system should be installed with the ice machine.

Clearance Requirements: Self-contained air-cooled ice machines must have a minimum of 6 inches (15cm) of clearance at the rear, top, and sides of the ice machine for proper air circulation.

Stacking

Ice-O-Matic GEM-MFI-HEM ice machines are not designed to be stacked.

Dispenser Application

The GEM and HEM ice machines are approved for specific dispenser applications, reference page 4. The MFI Series is not approved for dispenser applications.

Electrical Specifications

Refer to the serial plate at the rear of the ice machine to make sure proper voltage and circuit breaker size have been supplied. Make sure the machine is on a dedicated circuit. The GEM-MFI-HEM Series are not supplied with an electrical power cord and will need to be installed and wired per local electrical codes.

Adjustments

Level the machine within 1/8 inch in all directions. Adjust the cabinet or bin legs as required.

Check the bin control for proper operation.

Check the water level in the reservoir for proper adjustment.

Check the water regulating valve adjustment if water cooled.

Air and Water Cooled

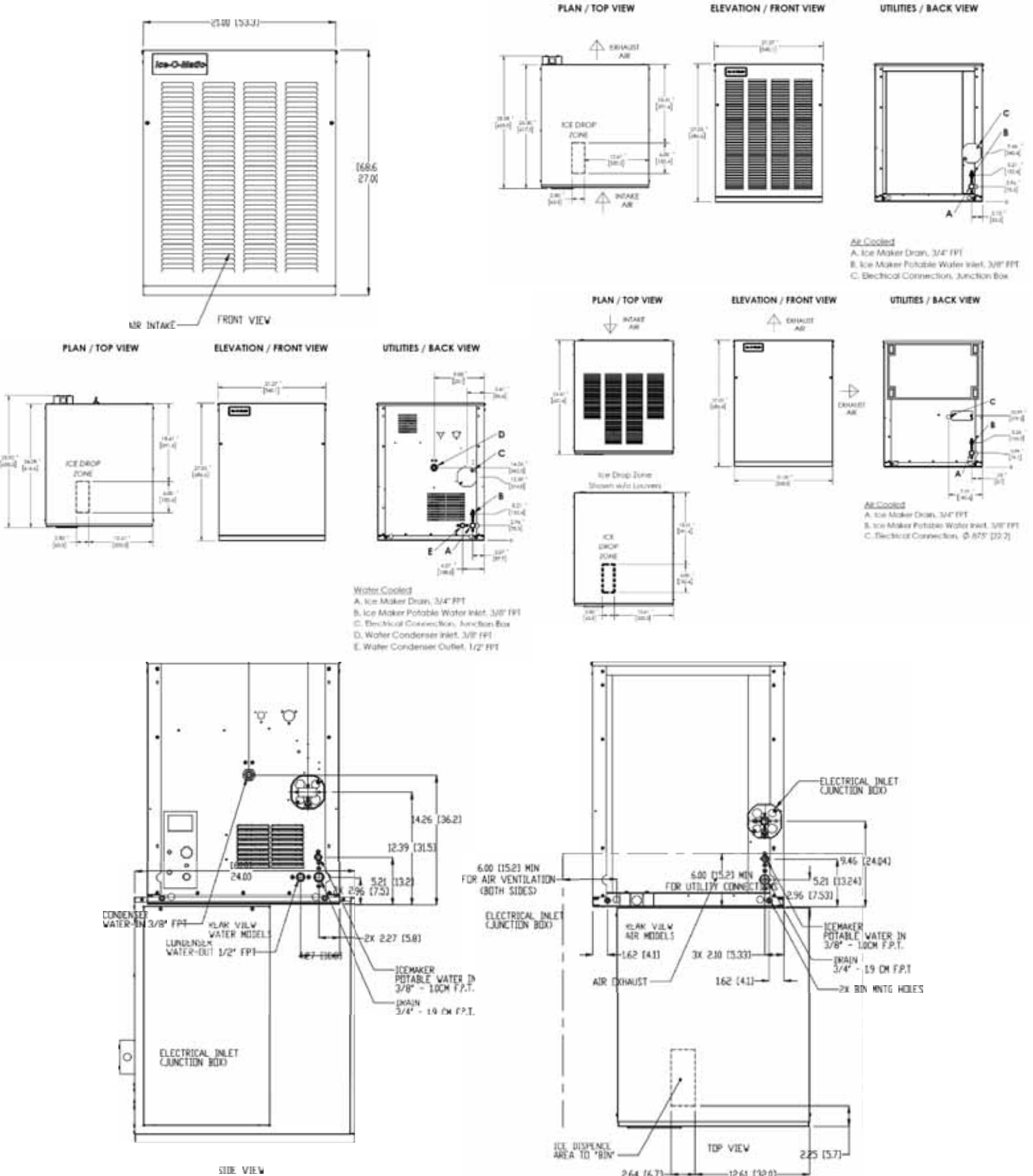

Remote

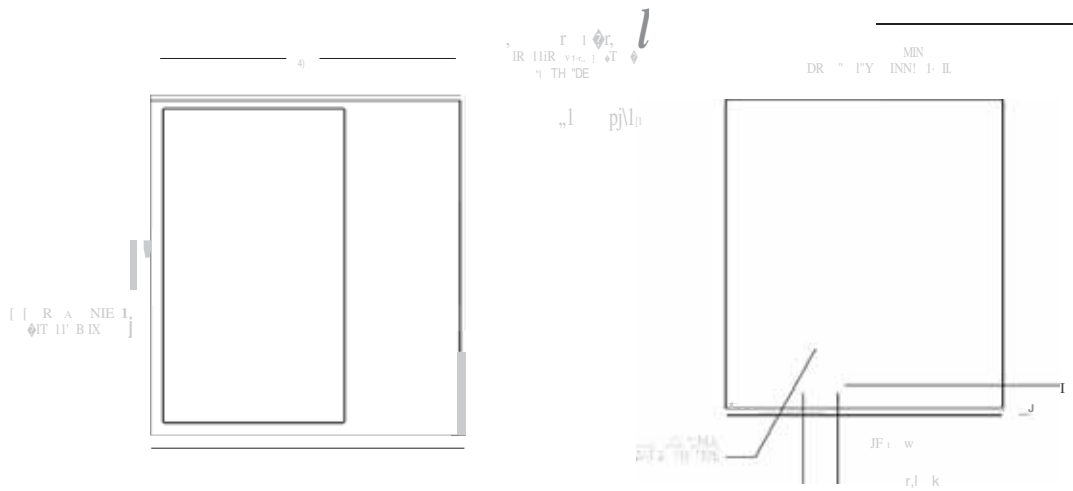
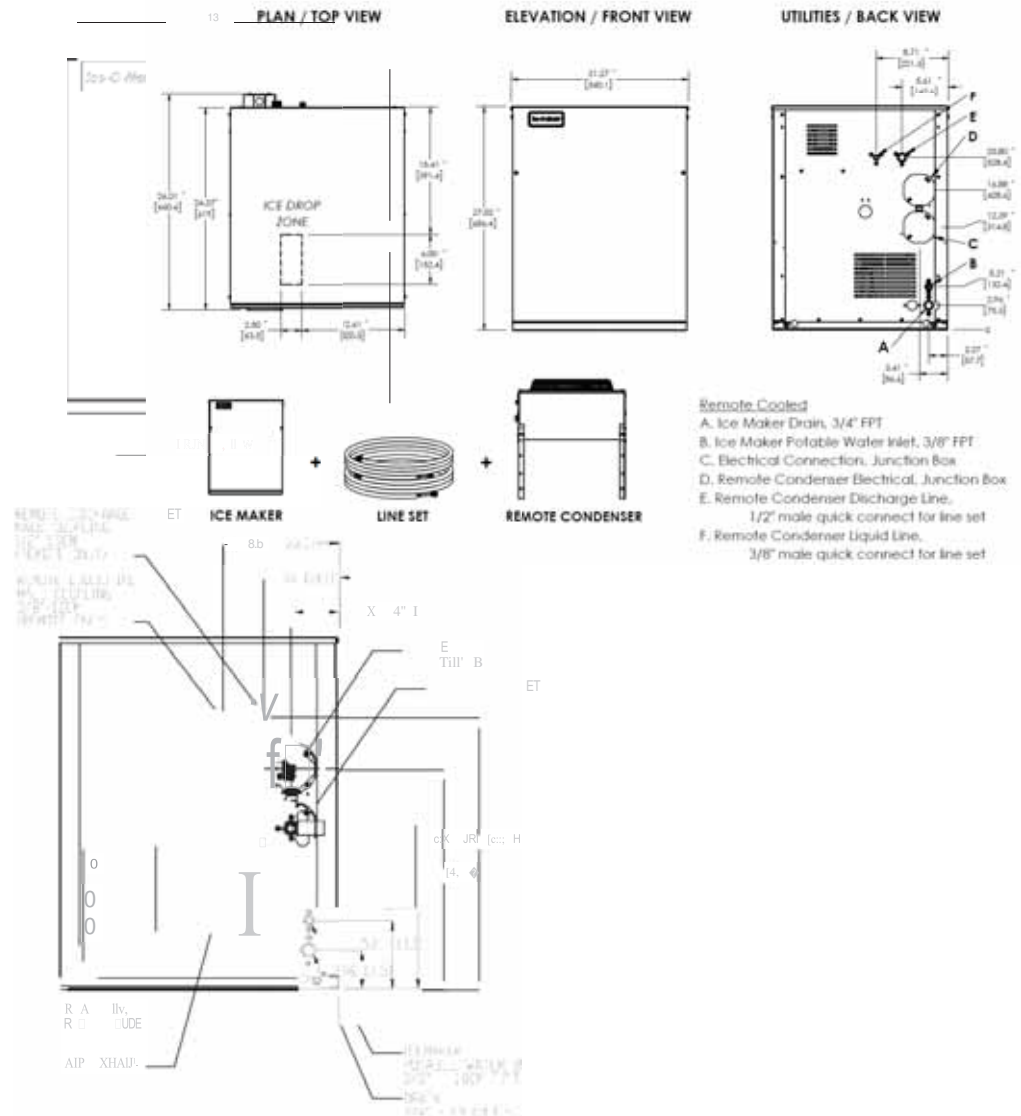

Bin Application

The GEM and HEM Series are designed to fit the following Ice-O-Matic Bins

- B42, using Bin Top KBT 24 (Note: 21 inch wide cabinet ONLY)
- B25, B40 B55 using Bin Top KBT 19.
- B100-B120 using Bin Top KBT 23 (one unit) or KBT 22 (two units).
- B700-30, B1000-48, B1325-60, B1600-60.

Dispenser Application

The GEM and HEM Series can be placed on and used with certain ice and beverage dispensers. Kits are required for proper operation. The MFI Series is not approved for dispenser applications.

IOM Gem Accessory List

Dispenser	GEM0450	GEM0650	GEM0956
ICE-O-Matic IOD150	KBT15022, KGEMDIV	KBT15022, KGEMDIV	KBT15022, KGEMDIV
ICE-O-Matic IOD200 or IOD250	KBT25022_KGEMDIV+KGEMBIOD	KBT25022_KGEMDIV+KGEMBIOD	KBT25022_KGEMDIV+KGEMBIOD,
Cornelius ED or DF150	KBT15022+R629088514*	KBT15022+ R629088514*	KBT15022+R629088514*
Cornelius ED or DF200	KBT25022+KGEM200	KBT25022+ KGEM200	KBT25022+ KGEM200
Cornelius ED or DF250	KBT25022+ KGEM250	KBT25022+ KGEM250	KBT25022+ KGEM250
Cornelius ED300	KGEM300+629087966*	KGEM300+629087966*	KGEM300+629087966*
Cornelius Flavor Fusion	KDIL-N-CFF+62988681 Black*	KDIL-N-CFF+62988681 Black*	KDIL-N-CFF+62988681 Black*
Lancer (Must have N in the part number) 30 Inch 4500 Model	KDIL-N-L and Lancer Part Number 82-3491	KDIL-N-L and Lancer Part Number 82-3491	KDIL-N-L and Lancer Part Number 82-3491

* Cornelius Part Number

All the dispensers have automatic agitation to keep the ice from clumping. If agitation is too frequent, the Pearl Ice will be damaged and will become difficult to dispense. The Ice-O-Matic and Cornelius dispensers need to be set to 2 seconds on every 3 hours and the Lancer needs to be set to 4 seconds on, 150 seconds off.

The Ice-O-Matic and most Cornelius dispensers also have a restrictor plate at the outlet of the hopper. When used, that plate should be adjusted to be 1.5 inch open to limit the speed of the Pearl Ice flows out during dispensing.

Ice Machine Specifications

Model Number	WxDxH (Inches)	Basic Electrical	Condenser	Minimum Circuit Ampacity	Maximum Fuse Size	Refrigerant Charge oz. R404
GEM0450A 2	21x24x27	115/60/1	Air	16.00	20	22
GEM0450W2	21x24x27	115/60/1	Water	14.35	20	18
GEM0650A2	21x24x27	115/60/1	Air	21.00	30	24
GEM0650W2	21x24x27	115/60/1	Water	19.50	30	19
GEM0650R2	21x24x27	115/60/1	Remote	23.50	30	208
GEM0655A2	21x24x27	230/50/1	Air	10.10	15	24
GEM0655W2	21x24x27	230/50/1	Water	9.50	15	19
GEM0956A 2	21x24x27	208-230/60/1	Air	11.80	15	30
GEM0956W2	21x24x27	208-230/60/1	Water	11.20	15	22
GEM0956R2	21x24x27	208-230/60/1	Remote	15.30	20	208
GEM0955A 2	21x24x27	230/50/1	Air	13.40	20	30
GEM0955W2	21x24x27	230/50/1	Water	13.10	15	22
GEM1306A	21x24x27	208-230/60/1	Air	15.80	20	30
MFI0500A2	21x24x27	115/60/1	Air	16.00	20	22
MFI0500W2	21x24x27	115/60/1	Water	14.35	20	18
MFI0800A2	21x24x27	115/60/1	Air	21.00	30	24
MFI0800W2	21x24x27	115/60/1	Water	19.50	30	19
MFI0800R2	21x24x27	115/60/1	Remote	23.50	30	208
MFI0805A2	21x24x27	230/50/1	Air	10.10	15	24
MFI0805W2	21x24x27	230/50/1	Water	9.50	15	19
MFI1256A2	21x24x27	208-230/60/1	Air	11.80	15	30
MFI1256W2	21x24x27	208-230/60/1	Water	11.20	15	22
MFI1256R2	21x24x27	208-230/60/1	Remote	15.30	20	208
MFI1255A2	21x24x27	230/50/1	Air	13.40	20	30
MFI1255W2	21x24x27	230/50/1	Water	13.10	15	22
MFI1506A	21x24x27	208-230/60/1	Air	15.80	20	30

Location:

Ice-O-Matic ice machines are designed to be installed indoors in a controlled environment. Install the ice machine in a location where it has enough space around it to be accessible for service. A minimum of 6 inches must be allowed at the back for air circulation on air cooled models. Try to avoid hot, dirty and crowded locations. Be sure that the location of the machine is within the environmental limitations.

Storage Bin:

Remove the bin packaging. Tip the storage bin on its back, using parts of the packaging to protect the exterior finish. Remove the skid and install the legs into the threaded holes in the bottom of the bin. Turn the leg levelers all the way in preparation for leveling later. Return the bin to the upright position.

Note: Do not push the bin into position but lift it there. Pushing a bin, especially one with ice in it, can cause damage to the bin legs and mounts.

Install the appropriate bin top according to the instructions provided with the bin top.

Ice machine:

The ice machine is heavy, so the use of a mechanical lift is recommended for lifting the machine high enough to install on top of the bin. After the unit is placed on the bin, line it up so it is even with the back side. Secure the ice machine to the bin with the hardware provided with the ice machine. Remove the front panel and remove any shipping blocks or packaging material.

Proper functioning of the bin door requires the bin door, when it is opened, to be in a stable position. If the ice machine is too far forward on the bin, the opened door may not be stable, resulting in an unexpected closing of the bin door.

If the ice machine is to be mounted on a bin or dispenser other than an Ice-O-Matic, refer to the manufacturer's instructions for machine mounting. Ice-O-Matic will not be responsible for damage or injury that results from unexpected closing of the bin door as a result of the ice machine being too far forward on the bin.

Water Limitations:

An ice machine is a food manufacturing plant: it takes a raw material, water and transforms it into a food product, ice. The purity of the water is very important in obtaining pure ice and maximizing product life. This section is not intended as a complete resource for water related questions, but it does offer these general recommendations:

- Check with a water treatment specialist for a water test and recommendations regarding water filters and treatment.
- In most cases, the water used to make ice should be filtered or treated, depending upon the water. There is no one type of water filter that is effective in all situations. That is why a water test is important.

RO Water Limitations:

Water conductivity must be no less than 35 microSiemens/cm.

Notice:

Ice-O-Matic ice machines are designed and manufactured with the highest regard for safety and performance and meet or exceed the standards of UL, NSF and CUL.

Ice-O-Matic assumes no liability or responsibility of any kind for products manufactured by Ice-O-Matic that have been altered in any way, including the use of any part and/or other components not specifically approved by Ice-O-Matic.

Ice-O-Matic reserves the right to make design changes and/or improvements at anytime. Specifications and design are subject to change without notice.

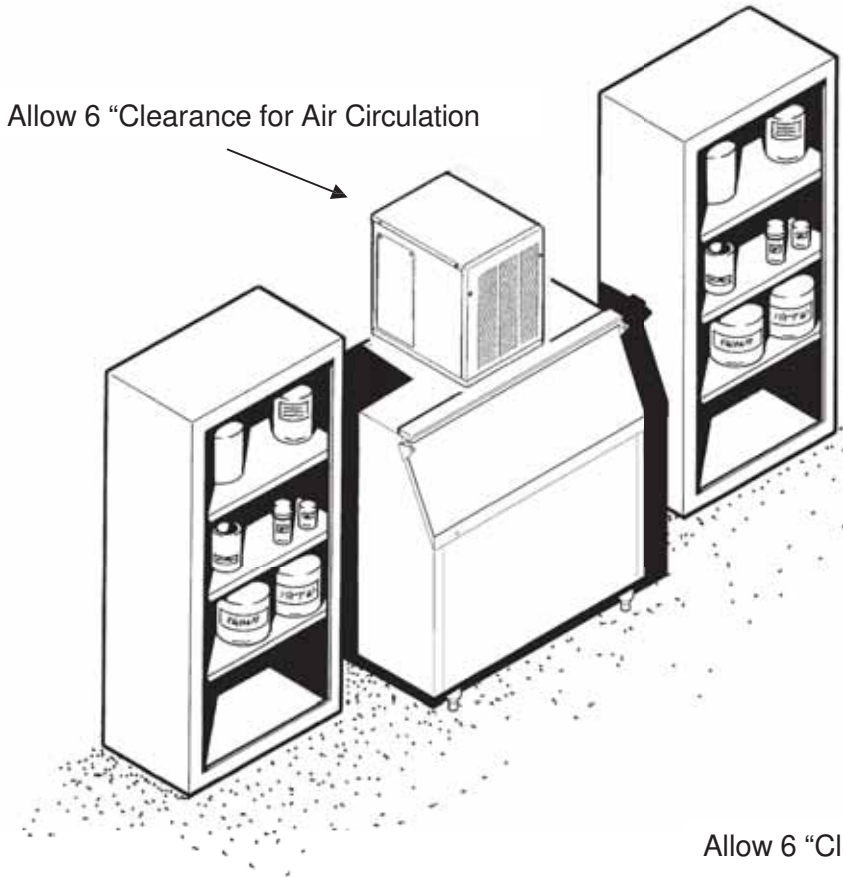

A proper installation locates the ice machine indoors, but in a place where the heat and noise it produces are not objectionable.

Air cooled machines discharge hot air out the back and must have a minimum of 6 inches of clearance behind the ice machine.

Space for maintenance access is also important. If two units are placed side by side on a bin, side access becomes even more important.

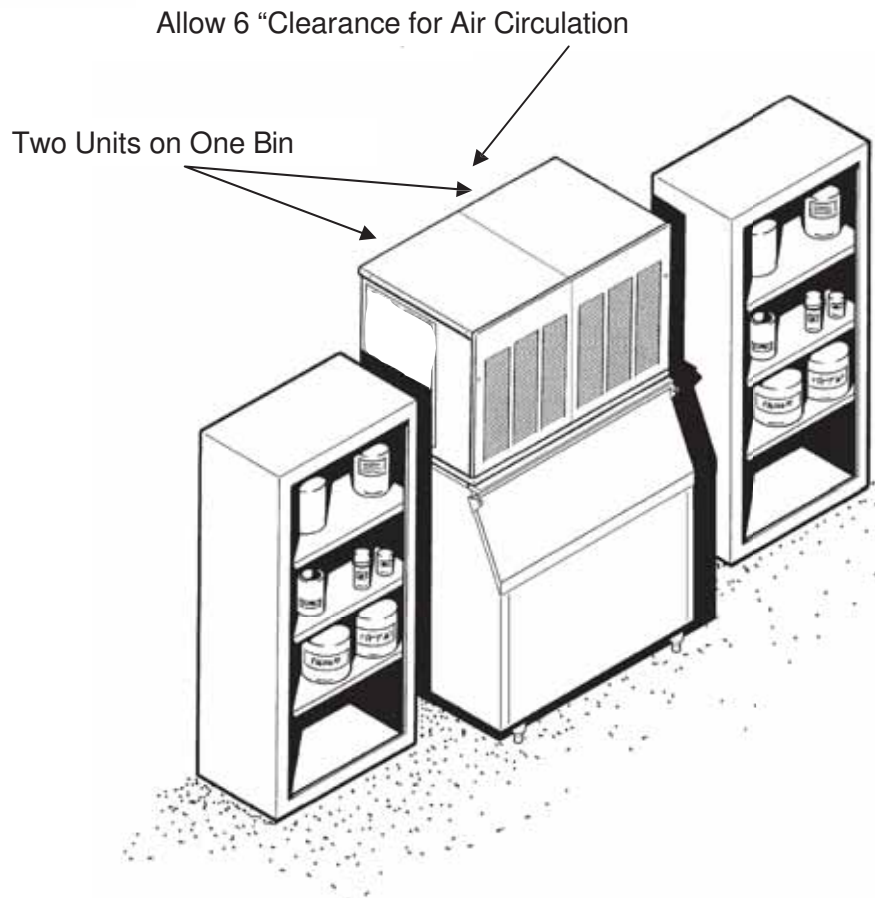

GEM-MFI SERIES

Remote Condenser

TOP VIEW

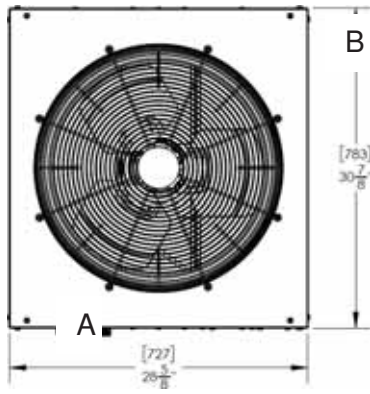

SIDE VIEW

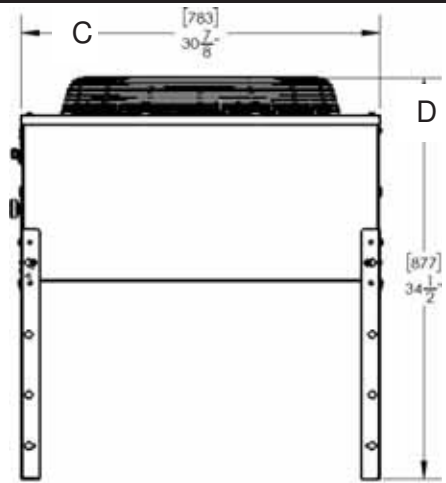

**FRONT VIEW/
ELECTRICAL
CONNECTIONS**

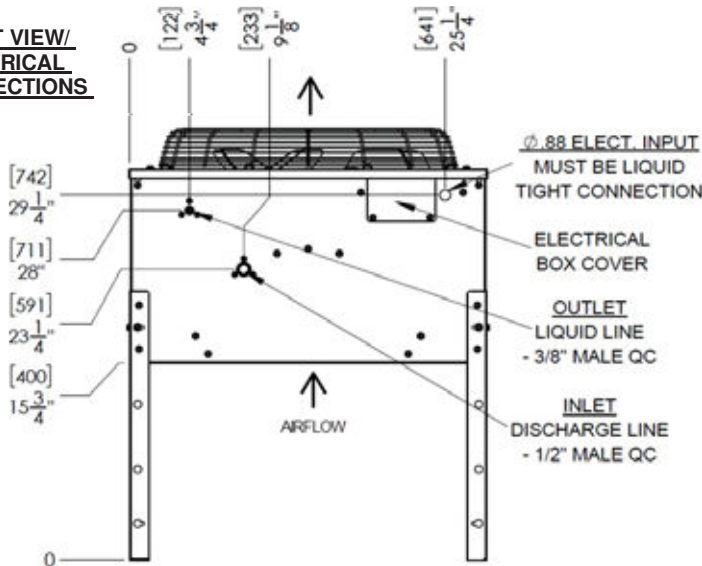

LINESET

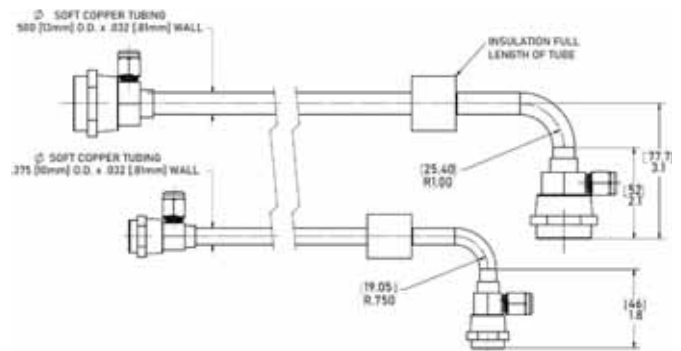

RC Dimensions (Inches)

	RC100G49	RC106G49	RC306C49 (W/HM)
A	27 5/8	28 5/8	35.34
B	30 7/8	30 7/8	30.87
C	30 7/8	30 7/8	30.87
D	34 1/2	34 1/2	35.02
GEM-MFI Model Number	GEM0650R49 MFI0800R49	GEM0956R49-MFI1256R49 GEM1306R49-MFI1506R49	GEM2006R49 MFI2306R49

LINESETS

RL404-25 (Replaces RT325404)	25 ft (7.6 m) Precharged Line Set / Tubing Kit for R404A Models
RL49-25	25 FT (7.6m) Precharged Line Set/ Tubing Kit R449a
RL404-40 (Replaces RT340404)	40 ft (12.0 m) Precharged Line Set / Tubing Kit for R404A Models
RL49-40	40 ft (12.0 m) Precharged Line Set / Tubing Kit for R449A Models
RL404-75 (Replaces RT375404)	75 ft (22.9 m) Precharged Line Set / Tubing Kit for R404A Models
RL49-75	75 ft (22.9 m) Precharged Line Set / Tubing Kit for R449A Models

Use the following for planning the placement of the remote condenser relative to the ice machine.

Location Limits: Remote condenser location must not exceed ANY of the following:

- Maximum rise from the ice machine to the remote condenser is 35 physical feet.
- Maximum drop from the ice machine to the remote condenser is 15 physical feet.
- Physical line set maximum length is 100 feet.
- Calculated line set length maximum is 150 feet.

Calculation Formula

- Drop = $dd \times 6.6$ (dd= distance in feet)
- Rise = $rd \times 1.7$ (rd = distance in feet)
- Horizontal Run = $hd \times 1$ (hd = distance in feet)
- Calculation: Drop(s) + Rise(s) + Horizontal Run = $dd+rd+hd$ =Calculated Line Length

Configurations that do NOT meet these requirements must receive written authorization from Ice-O-Matic. This includes multipass or rack system remote condensers.

Do NOT:

- Route a line set that rises, then falls, then rises.
- Route a line set that falls, then rises, then falls.

Calculation Example 1:

The remote condenser is to be located 5 feet below the ice machine and then 20 feet away horizontally. (5 feet x 6.6=33 feet) + (20 feet) = 53 feet. This location would be acceptable.

Calculation Example 2:

The remote condenser is to be located 35 feet above the ice machine and then 100 feet away horizontally. (35 feet x 1.7=59.5 feet) + (100 feet) = 159.5 feet. 159.5 feet is greater than the 150 maximum is NOT acceptable.

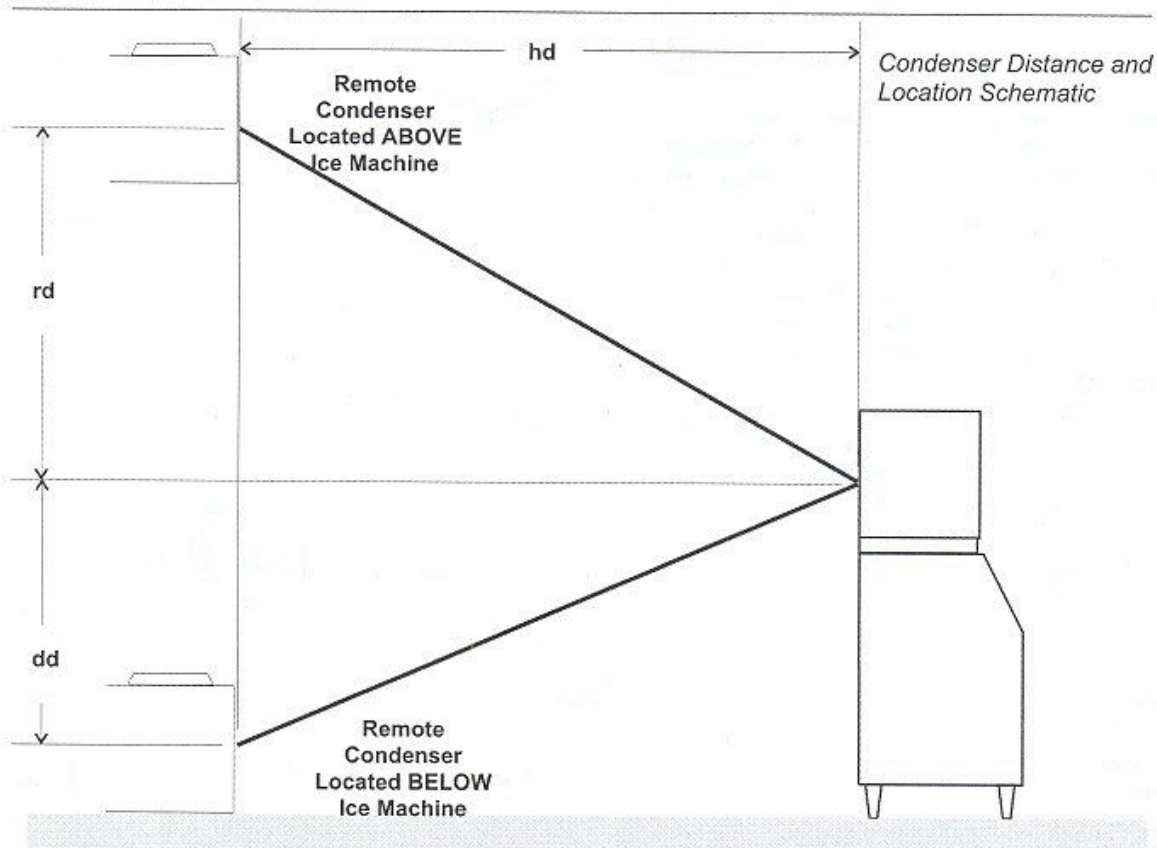

Remote Condenser Location:

Limited to a 25 foot or a 40 foot length of precharged refrigerant tubing connecting the ice machine to the remote condenser. The remote condenser must be above or level with the ice machine. Select the best available location, protecting the remote condenser from extremes of dirt, dust and sun. Meet all applicable building codes. Usually the services of a licensed electrician are required.

Roof Attachment:

1. Install and attach the remote condenser to the roof of the building, using the methods and practices of construction that conform to the local building codes, including having a roofing contractor secure the remote condenser to the roof.
2. Have an electrician connect the remote condenser fan motor to the ice machine, using the junction box at the back of the ice machine.

Precharged Line Set Routing

CAUTION: Do not connect the precharged tubing until all routing and forming of the tubing is complete. See the coupling instructions for connecting information.

1. Each set of precharged tubing refrigerant lines consists of a 3/8 diameter liquid line and a 1/2 inch diameter discharge line. Both ends of each line have quick connect couplings, one end has a Schrader valve connection, that end goes to the condenser.

Note: The openings in the building ceiling or wall, listed in the next step, are the minimum sizes recommended for passing the refrigerant lines through.

2. Have the roofing contractor cut a minimum hole for the refrigerant lines of 1.750 inch. Check local codes, a separate hole may be required for the electrical power to the condenser.

CAUTION: DO NOT KINK OR CRIMP REFRIGERANT TUBING WHEN INSTALLING IT.

3. Route the refrigerant lines through the roof opening. Follow straight line routing whenever possible. Any excess tubing **MUST** remain within the building.
4. Spiral the excess length of precharged tubing inside the building. Use a horizontal spiral (does not need to be as tight as illustrated) to avoid any traps in the lines.
5. Have the roofing contractor seal the holes in the roof per local codes.

CAUTION: The couplings on the sets of precharged lines are self sealing when installed properly. Carefully follow the instructions:

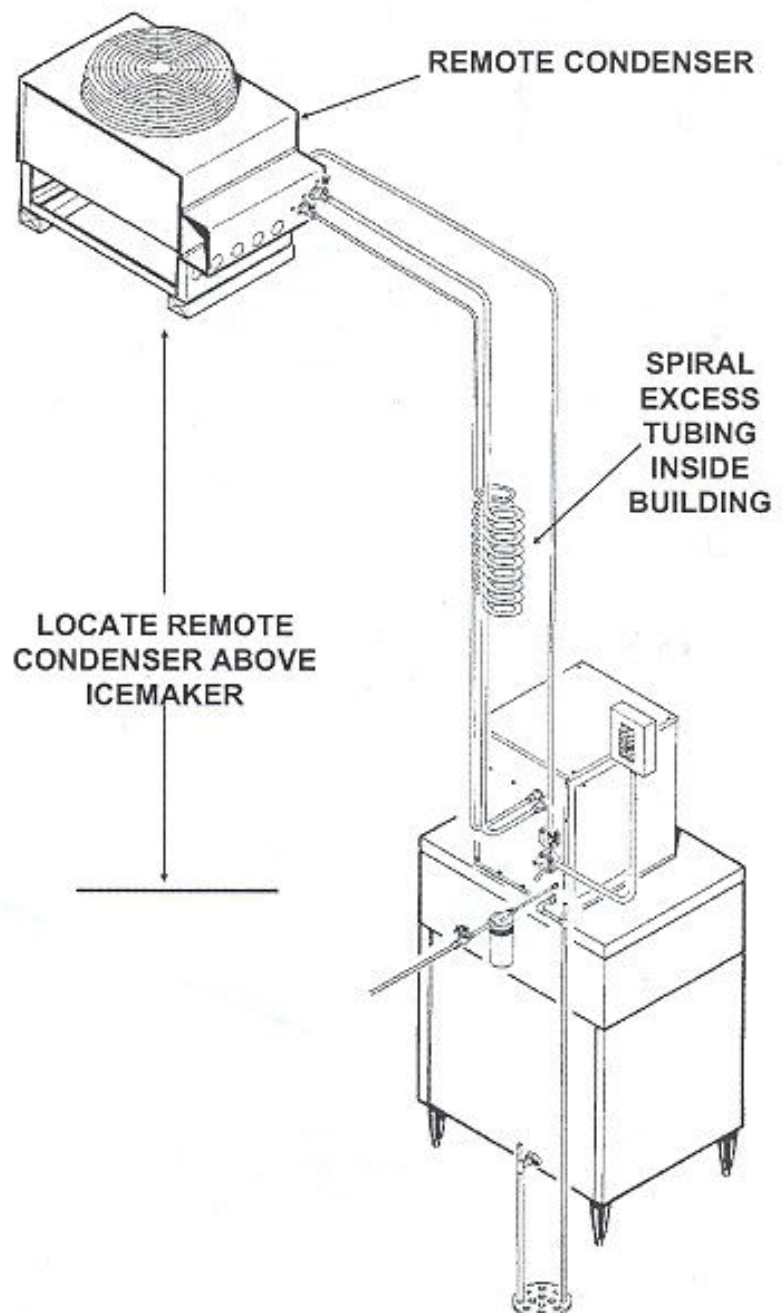

Typical Installation

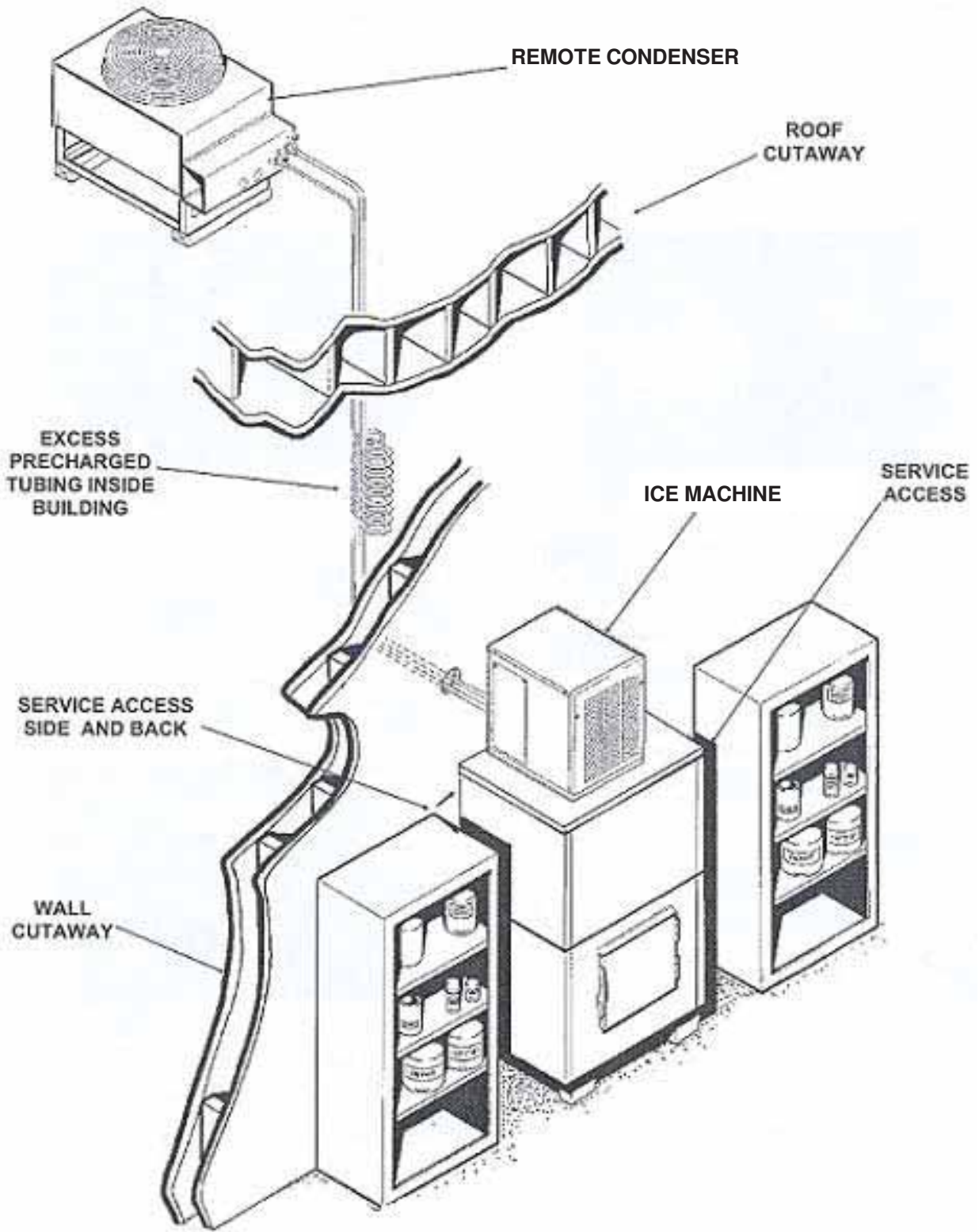

Coupling Instructions:**Initial Connections:**

1. Remove the protector caps and plugs. Wipe the seats and threaded surfaces with a clean cloth to be certain that no foreign matter remains on them.
2. Lubricate the inside of the couplings, especially the O-Rings with refrigerant oil.
3. Position the fittings on the correct connections on the remote condenser and ice machine.
 - The 1/2 inch discharge line (**Schrader valve end**) goes to the remote condenser fitting marked "Discharge Line"
 - The 3/8 inch liquid line (**Schrader valve end**) goes to the remote condenser fitting marked "Liquid Line".
 - The 1/2 inch discharge line goes to the ice machine fitting marked "Discharge Line".
 - The 3/8 inch liquid line goes to the ice machine fitting marked "Liquid Line".

**Final Connections:**

- 4a. Begin by tightening the couplings together by hand. Continue to turn the swivel nuts by hand until it is certain that the threads are properly engaged.

- 4b. Using two wrenches, one to rotate the swivel nut and one to hold the tubing, tighten each coupling.

It is **CRITICAL** that **ONLY** the NUT on the precharged tube be turned or the diaphragms will be torn loose by the piercing knives and be loose in the refrigeration system causing severe operational problems.

Note: As the coupling is tightened, the diaphragms in the quick connect couplings will begin to be pierced. As that happens, there will be increased resistance to tightening the swivel nut.

- 4c. Continue tightening the swivel until it bottoms out or a very definite increase in resistance is felt (no threads should be showing). Do **NOT** over tighten.

5. Using a marker or pen, mark a line lengthwise from the coupling union nut to the bulkhead. Then tighten the coupling and additional 1/4 turn. As the nut turns, the line will show when the 1/4 turn is made.

6. After all connections are made, and after the king valve has been opened, check the couplings for leaks.



Water Inlet:

- **Air Cooled Models:** The recommended water supply is clean, cold water. Use 3/8 inch O.D. copper tubing, connect to the 3/8 FPT at the back of the cabinet. Install a hand valve near the machine to control the water supply.
- **Water Cooled Models:** A separate 3/8 inch O.D. copper line is recommended, with a separate hand valve to control it. Connect to the 3/8 inch FPT condenser inlet at the back of the cabinet. The water pressure to all lines must always be above 20 psig, and below 80 psig.
- **Water Treatment:** In most areas, a water filter of some type will be useful. In areas where the water is highly concentrated with minerals, the water should be tested by a water treatment specialist, and the recommendations of the specialist regarding filtration and/or treatment should be followed.

Drains:

- **Air Cooled Models:** Connect a rigid drain tube to the 3/4 FPT drain fitting at the back of the cabinet. The drain is a gravity type, and a 1/4 inch per foot fall is the minimum acceptable pitch for the drain. There should be a vent at the highest point of the drain line, and the ideal drain receptacle would be a trapped and vented floor drain. Use only 3/4 inch rigid tubing.
- **Water Cooled Models:** Connect a separate drain line to the 1/2 inch condenser drain connection at the back of the cabinet. Do not vent this drain.
- **Storage Bin:** Connect a separate gravity type drain line to the ice storage bin drain. Vent this drain if there is a long horizontal run from the bin to the floor drain. Insulation of this drain line is recommended.

WATER COOLED MODELS

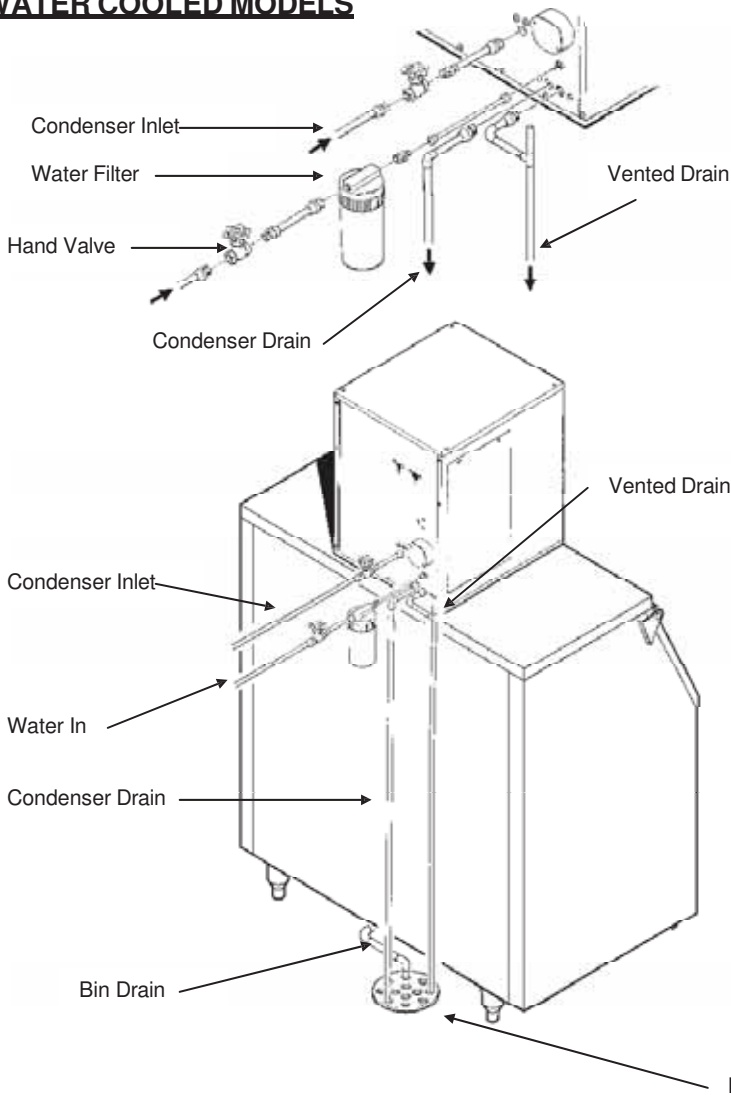

AIR COOLED MODELS

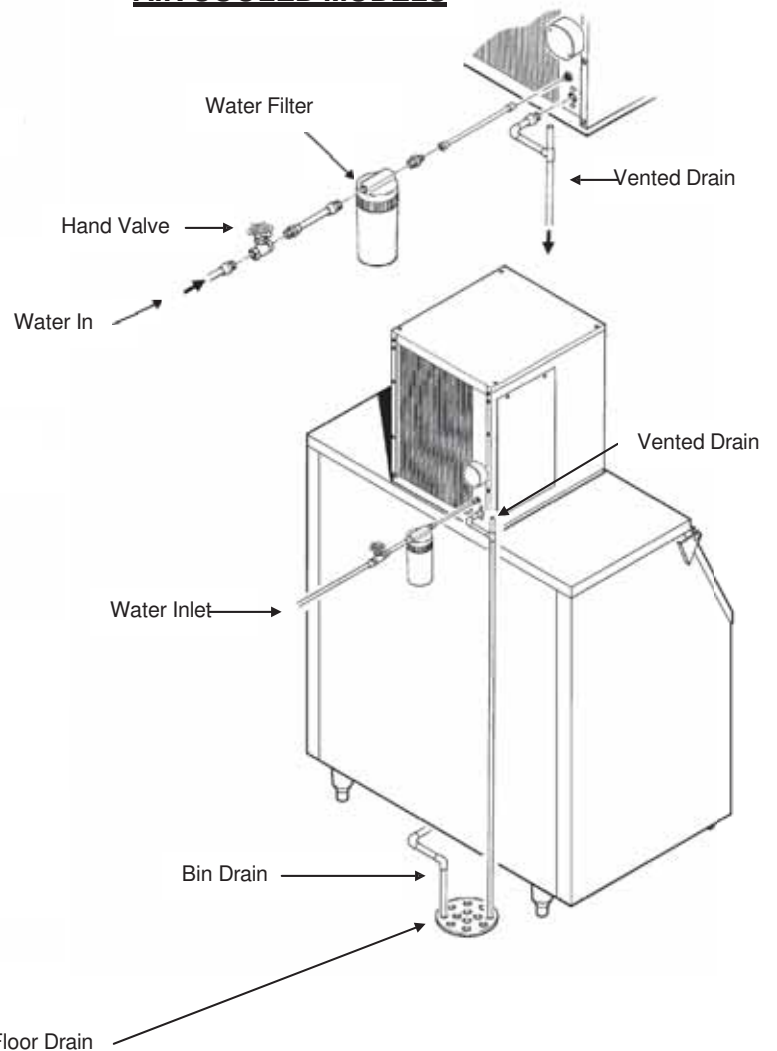

Water Inlet:**• Remote Cooled Models:**

The recommended water supply is cold water. Use 3/8 inch O.D. copper tubing, connect to the 3/8 inch FPT on the back of the cabinet. Install a hand valve near the machine to control the water supply.

Drains:**• Remote Cooled Models:**

There is one 3/4 inch FPT drain at the back of the cabinet; the drain line is of the gravity type, and 1/4 inch per foot fall is an acceptable pitch for the drain tubing. There should be a vent at the highest point of the drain line, and the ideal drain receptacle would be a trapped and vented floor drain. Use only 3/4 inch rigid tubing.

Storage Bin:

Install a separate gravity type drain. Insulation of this drain line is recommended.

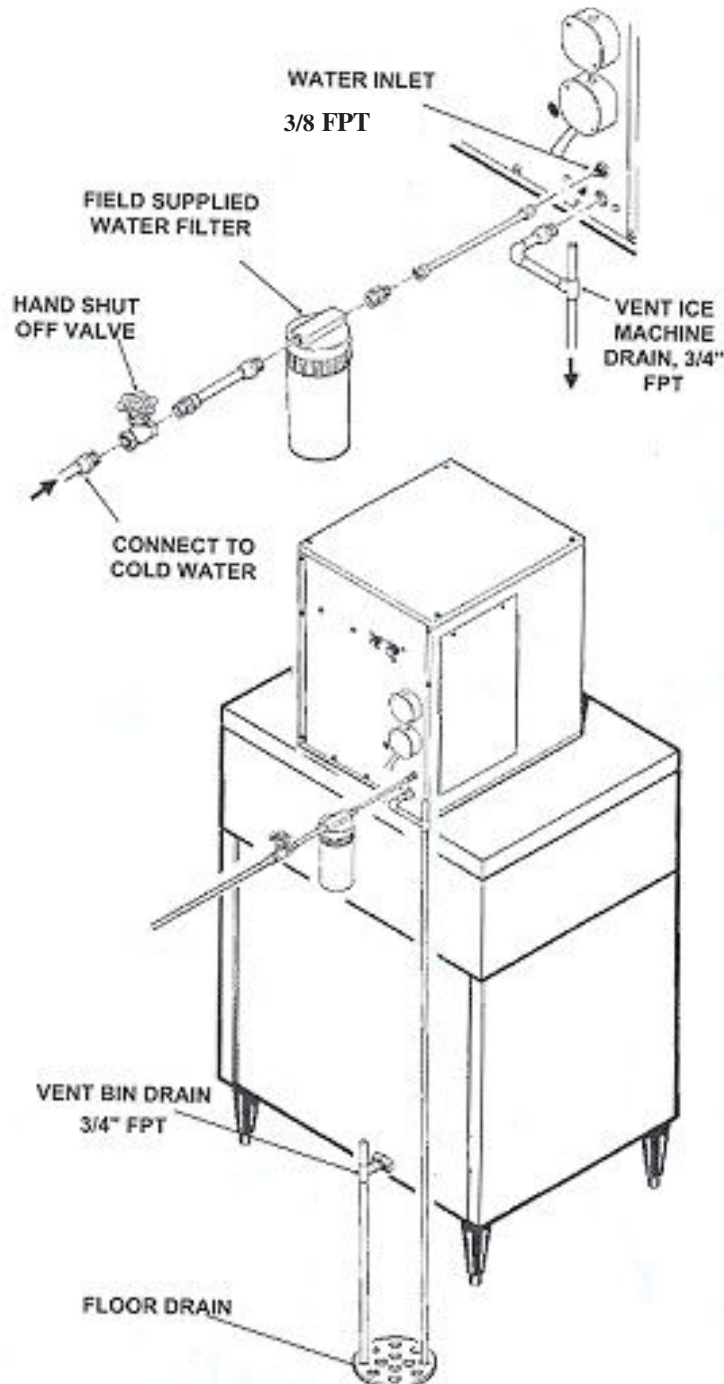

Electrical Connections:

Check the ice machine nameplate (located on the back panel) for the voltage requirements, and minimum circuit ampacity. The ice machine requires a solid chassis to earth ground.

Connect the ice machine to its own electrical circuit so it is individually fused. Voltage variation must remain within the limitations, even under starting conditions.

**Note: All external wiring must conform to national, state and local electrical codes.
The use of a licensed electrician is required to perform the electrical installation.**

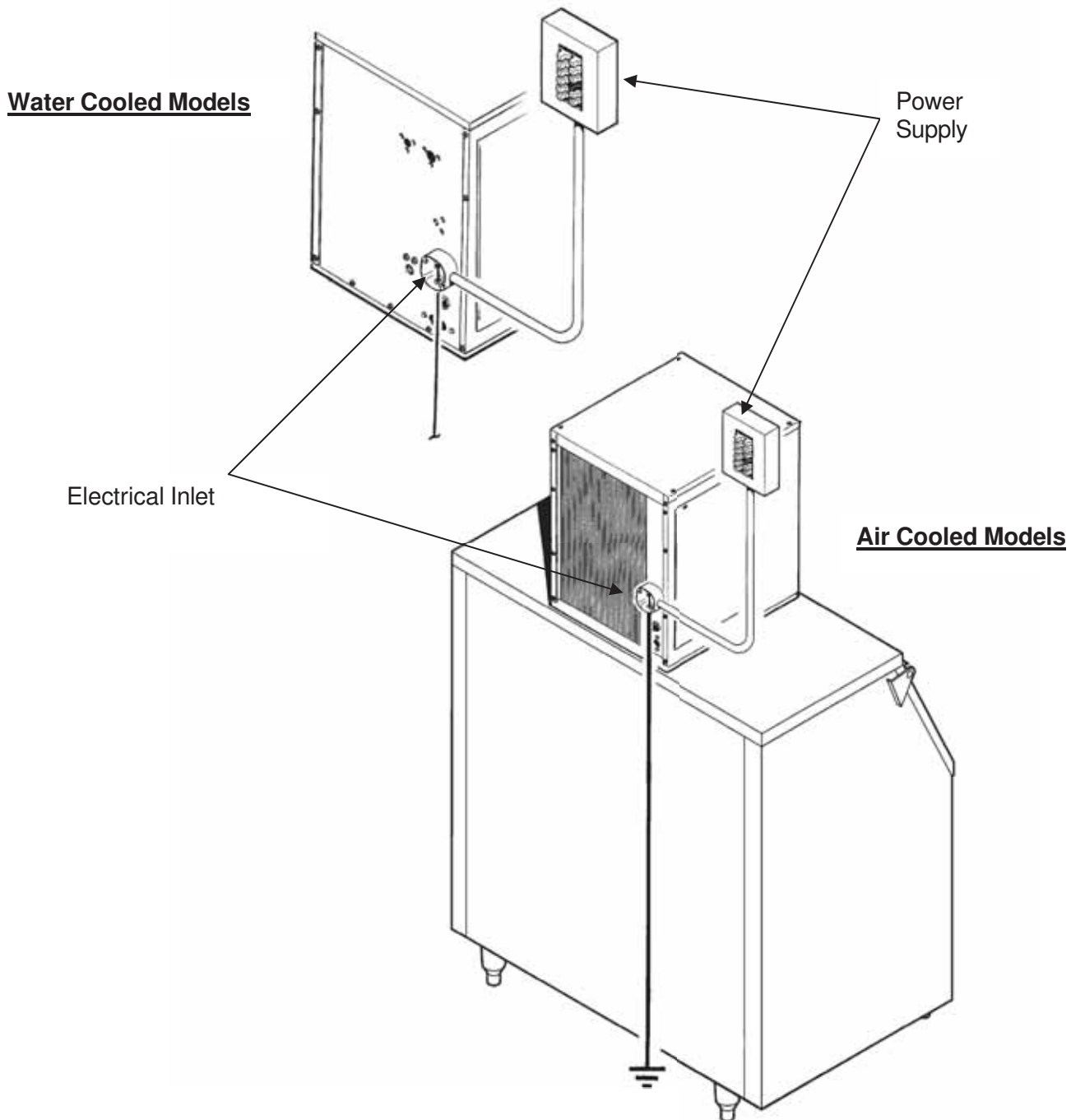

INSTALLATION MUST CONFORM TO ALL APPLICABLE CODES.

Connect the electrical power to the unit to the wires in the junction box at the rear of the machine. Check the nameplate (located on the back panel) for the voltage requirements, and for the minimum circuit ampacity. The machine requires a solid chassis to earth ground wire.

Connect the ice machine to its own electrical circuit so it is individually fused. Voltage variation must remain within design limitations, even under starting conditions.

There is a separate junction box for the remote condenser fan motor. Install an interconnecting wire between the remote condenser and the junction box at the back of the ice machine.

The remote condenser must be wired to the ice machine in accordance with local and national electrical codes with a minimum of 18 AWG. wire with a ground bonding wire connected to the ground screw provided in both the condenser and machine field wiring boxes. All outdoor wiring must be in rainproof conduit.

All external wiring must conform to national, state and local electrical codes. The use of a licensed electrician is required to perform the electrical installation.

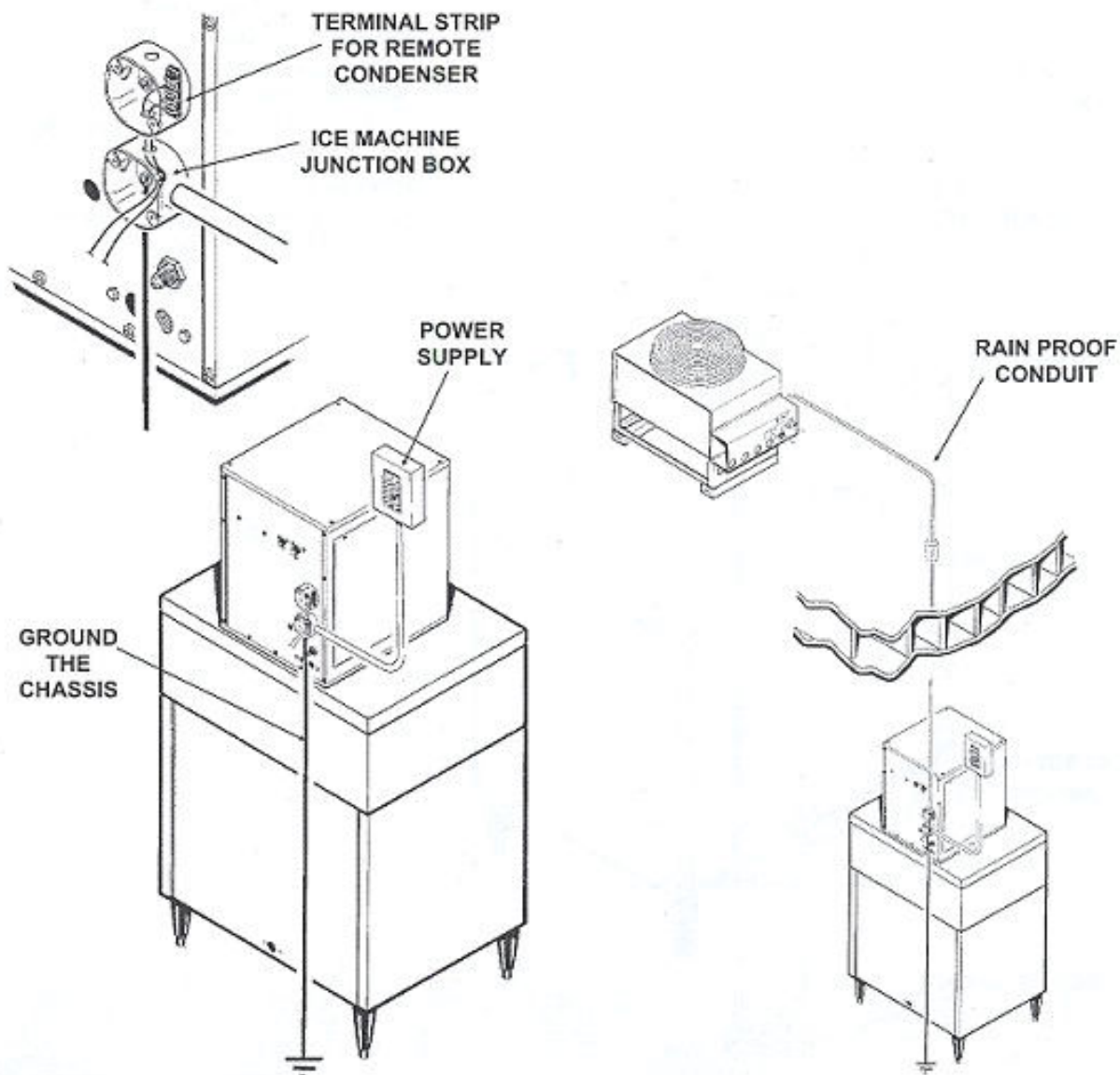

Completed Installation

A typical installation should generally appear as illustrated below. The best place for the remote condenser is above the ice machine, although other locations are permissible.

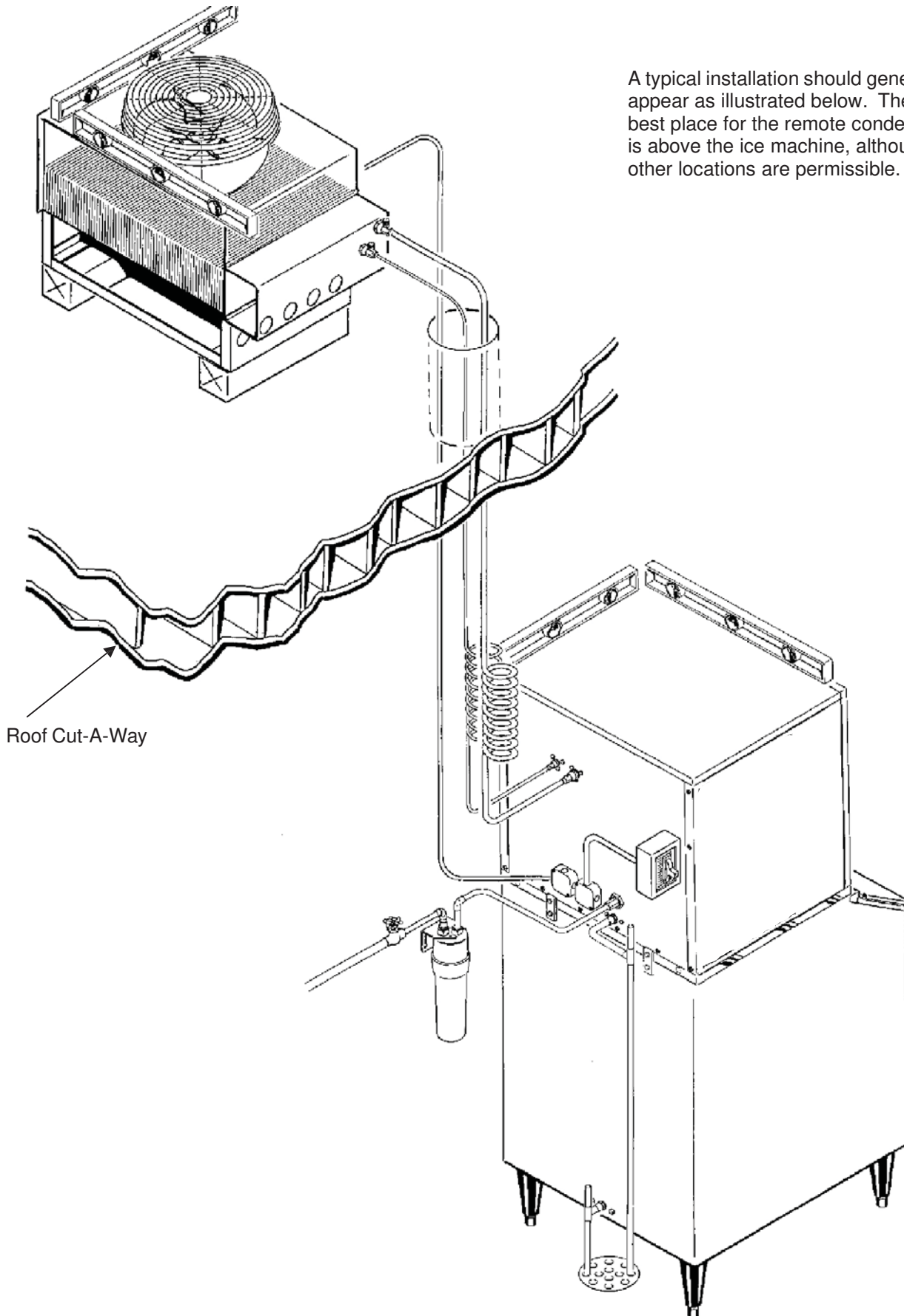

Final Check List: Air and Water Cooled

- ____ 1. Is the ice machine installed indoors in a location where the air and water temperatures are controlled and where they do not exceed the design limitations?
- ____ 2. Is there an electrical service disconnect within sight of the installed machine?
- ____ 3. Has the voltage been checked and compared to the nameplate requirements?
- ____ 4. Have all the plumbing connections been made and checked for leaks?
- ____ 5. Is the ice machine and storage bin level?
- ____ 6. Is there a minimum of 6 inches of clearance at the back of the machine for proper service access and air circulation?
- ____ 7. Is the water pressure a minimum of 20 psig?
- ____ 8. Has the ice machine been secured to the bin?
- ____ 9. Is there clearance over the top of the ice machine for service access?
- ____ 10. Is there a water shut off valve installed near the ice machine?
- ____ 11. Have all the shipping blocks been removed from the ice machine?

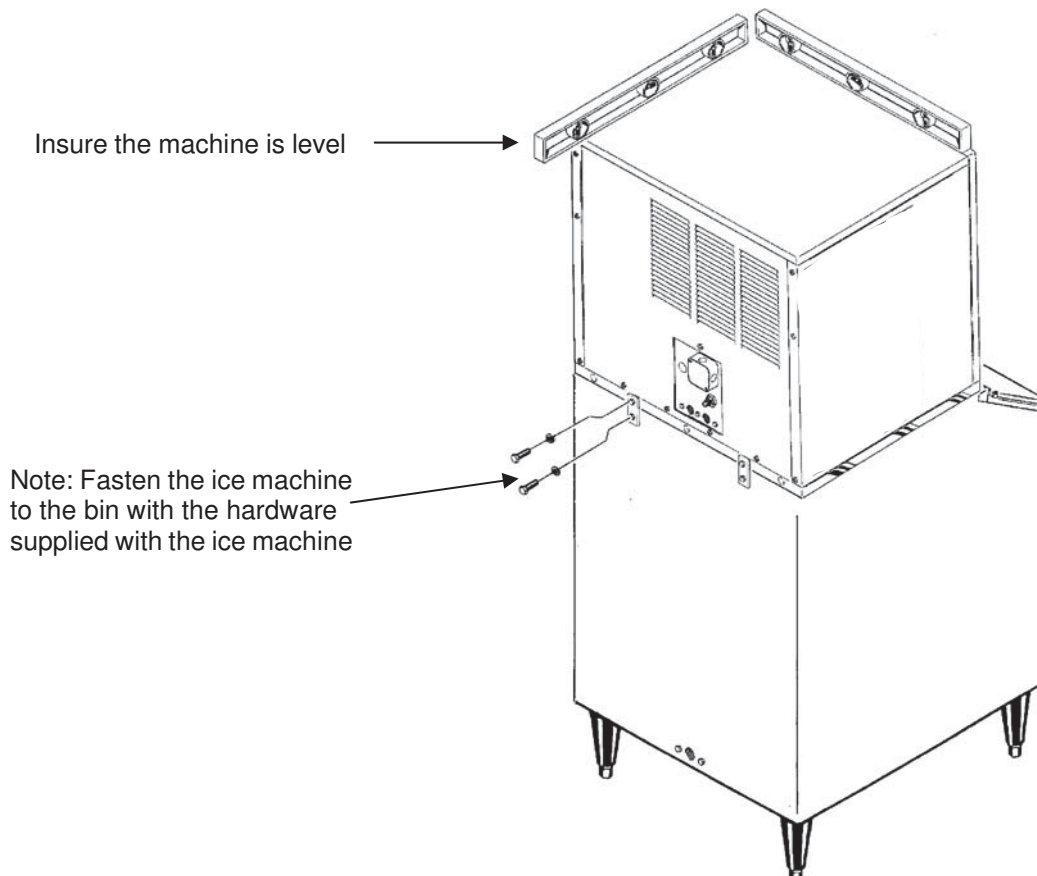

Final Check List: Remote

- 1. Is the ice system installed indoors in a location where air and water temperatures are controlled, and where they do not exceed the design limitations?
- 2. Is there an electrical service within sight of the installed machine? Has the voltage been checked, and compared to nameplate requirements?
- 3. Have all the plumbing connections been made and checked for leaks?
- 4. Has the machine and bin been leveled?
- 5. Is there a minimum of 6 inches clearance at the rear, left and right of the machine for proper service access?
- 6. Is the water pressure a minimum of 20 psig?
- 7. Has the machine been secured to the bin or dispenser?
- 8. Is there a water shut off valve installed near the machine?
- 9. Is the remote condenser installed per local codes, and in a place where it has adequate ventilation and minimal solar heat gain?
- 10. Has all shipping material and literature (inside front panel) been removed from the units?
- 11. Have the remote condenser and pre-charged lines been properly installed?
- 12. Has the electrical connection between the ice maker and condenser been made?
- 13. Verify that the master switch is in the OFF position.
- 14. Switch ON the electrical power.
- 15. Refer to the Pre-Start instructions

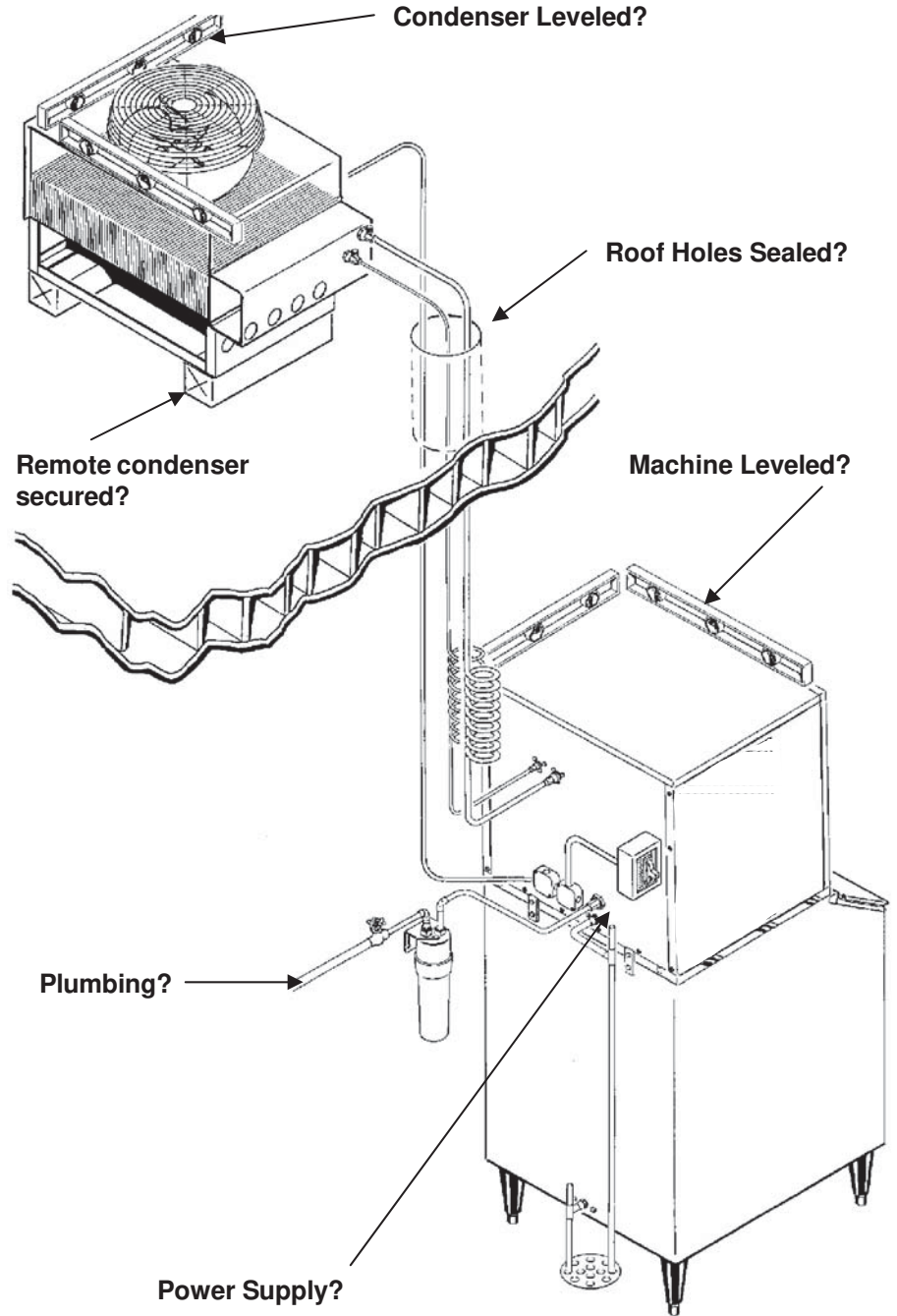

Pre-Start Inspection: Air and Water Cooled

1. Remove the front and side service panels.
2. Check that any shipping blocks have been removed.
3. Inspect the interior of the ice machine for loose screws or wires.
4. Check that no refrigerant lines are rubbing each other.
5. Check that the fan blades turn freely (Air Cooled).
6. Check that the unit is installed correctly according to the final check list.

Start Up:

1. Go through the pre-start inspection.
2. Open the hand valve, observe that water enters the water reservoir, fills the tube from the water reservoir to the evaporator and then shuts off. (Water cooled only, Turn the water supply **ON** to the water cooled condenser). Check for leaks.
3. Switch the master (mode) switch **ON**. The electrical start up sequence in automatic.
 - a. There should be a short (15 second) delay before the gear motor starts.
 - b. After the gear motor starts, the compressor will start.
4. On air cooled models, the condenser will begin to discharge warm air, on water cooled models, the water regulating valve will open and warm water will be discharged into the drain.
5. The unit should soon be making ice, if desired; the low side pressure may be checked: it should be 34-38 psig. R- 290 units it is not recommended to check pressure as this is a critically charged unit. however the pressure should be 26-28 psig.

The suction line temperature at the compressor is normally very cold, nearly to the point of frost up to the compressor body, but not on it.

The air cooled discharge pressure will depend upon air and water temperatures, but should be between 200 psig and 280 psig. R290 Discharge around 150-200 psig.

The water cooled discharge pressure should be a constant at about 245 psig. R290 unit around 175 psig

Note: The above pressures are for new, clean machines. You can expect to see some values higher, and some lower between different units.
6. **There are no adjustments to make**, so replace the panels.
7. Clean and/or sanitize the storage bin interior, wipe off the exterior with a clean, damp cloth.
8. Give the owner/user the service manual, instruct him/her in the operation of the unit, and make sure they know who to call for service.
9. Fill out the manufacturer's registration and mail it to Ice-O-Matic.

Pre-Start Inspection: Remote

1. Remove the front and side service panels.
2. Check that any shipping blocks have been removed.
3. Inspect the interior of the ice machine for loose screws or wires.
4. Check that no refrigerant lines are rubbing each other.
5. Check that the fan blades turn freely (Remote Condenser).
6. Check that the refrigerant lines are properly installed.
7. Check that the electrical power has been on for at least 4 hours and that the compressor dome is warm.
8. Check that the unit is installed correctly according to the final check list.

Start Up:

1. Go through the pre-start inspection.
2. Open the hand valve, observe that water enters the water reservoir, fills the tube from the water reservoir to the evaporator and then shuts off. (Water cooled only, Turn the water supply **ON** to the water cooled condenser). Check for leaks.
3. Open the King Valve.
4. Switch the master switch **ON**. The electrical start up sequence is automatic.
 - a. There should be a short (15 second) delay before the gear motor starts and the liquid line opens.
 - b. After the liquid line opens, the low pressure control will close and the compressor will start.
5. The remote condenser fan turns, and the condenser begins to discharge warm air.
6. The unit should soon be making ice, if desired; the low side pressure may be checked: it should be 28-35 psig. R-449A refrigerant is very similar to R-404A it should be 29-36 The air cooled discharge pressure will depend upon air and water temperatures, but should be between 200 psig and 280 psig. R-449A 180 psig and 290 psig.
7. **There are no adjustments to make**, so replace the panels.
8. Clean and/or sanitize the storage bin interior, wipe off the exterior with a clean, damp cloth.
9. Give the owner/user the service manual, instruct him/her in the operation of the unit, and make sure they know who to call for service.
10. Fill out the manufacturer's registration and mail it to Ice-O-Matic.

- **Control Box:** Contains the electrical controls that operate the machine.
- **High Pressure Cut Out Switch:** An auto-reset switch sensing the high side refrigeration pressure. It will shut the machine off if the discharge pressure exceeds 450 psig. R-290 cut out is 350 psig
- **Pump Down Control:** A switch to control the compressor, depending upon low side pressure closes at 30 PSIG and opens at 15 PSIG.
- **Evaporator:** A vertical stainless-steel tube refrigerated, and water filled. Utilizes a stainless-steel auger.
- **Water Reservoir:** Float operated, it maintains the water level in the evaporator at a constant level, and it also contains the water level sensor.
- **Water Level Sensor:** Senses if there is water in the reservoir to make ice out of. Will shut the ice machine off if there is no water in the reservoir.
- **Ice Discharge Chute:** Directs the ice produced by the evaporator into the storage bin.
- **Ice Level Sensor:** An “electronic eye”, it senses the presence of ice in the bottom of the discharge chute. Operates to turn on and off automatically as the level of ice in the bin changes.
- **Gear Motor:** An oil filled, speed reduction gearbox, driving the auger.
- **Cleaning Drain Tube:** When uncapped and lowered, drains the evaporator.
- **Compressor:** The refrigerant vapor pump.
- **Expansion Valve:** The refrigerant metering device.

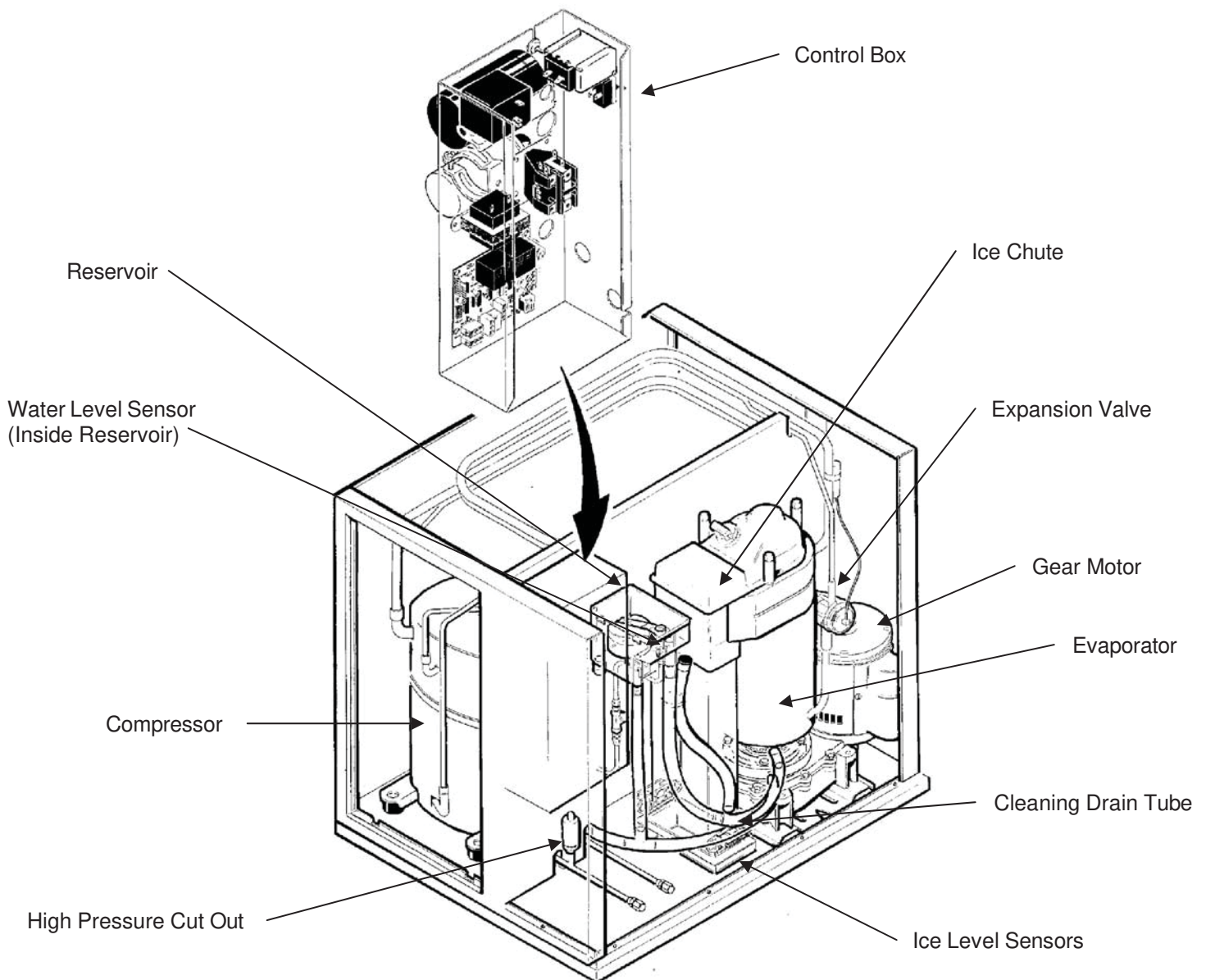

- **Contactor:** A definite purpose contactor connecting the compressor and the fan motor to the power supply.
- **Circuit Board:** Controls the operation of the ice machine using input from the sensors and pressure controls. Switches loads on and off thru relays. (Reference Photo Below)
- **Potential Relay:** The compressor start relay.
- **Mode (ON/OFF) Switch:** Manual control for the machine.

Control Board

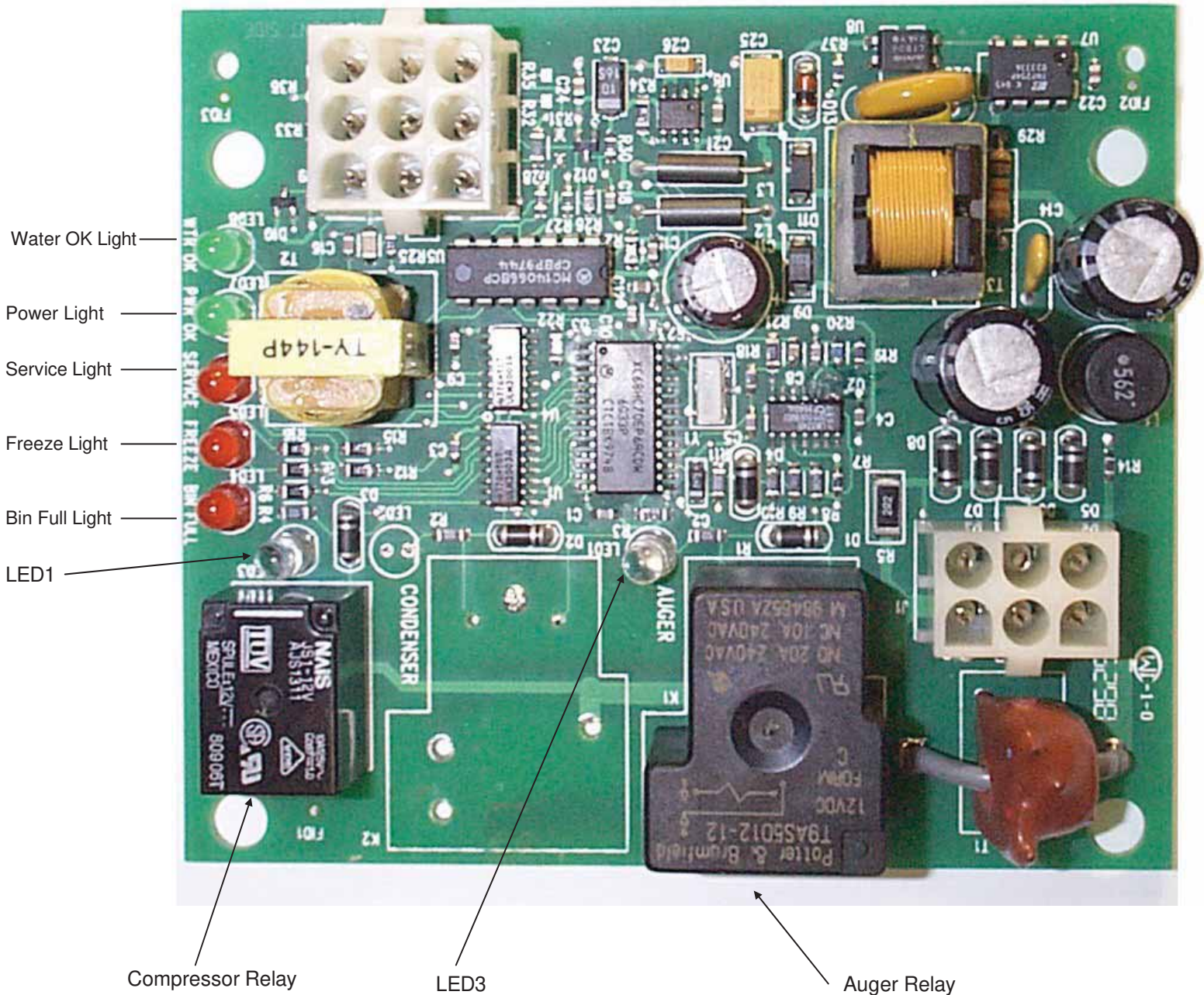

- **Evaporator:** A refrigerated vertical tube filled with water and containing a water seal and auger.
- **Auger:** A solid stainless steel double spiral auger, it pushes the ice crystals up to the top of the evaporator.
- **Water Seal:** A two part “face” seal, the top half rotating with the auger, the bottom half stationary, the sealing action being where the two “faces” meet.
- **Ice Sweep:** A plastic cap with “fingers”. It revolves with the auger to “sweep” the ice into the ice chute.
- **Breaker (Divider):** Where the ice is compressed and much of the extra water is squeezed out of it before it is discharged into the bin.
- **Motor:** A split phase motor that drives the gear reducer.
- **Thrust Bearings:** As the ice is pushed up the evaporator, the auger is thrust down, and pressure from the auger thrust is taken up by this bearing.

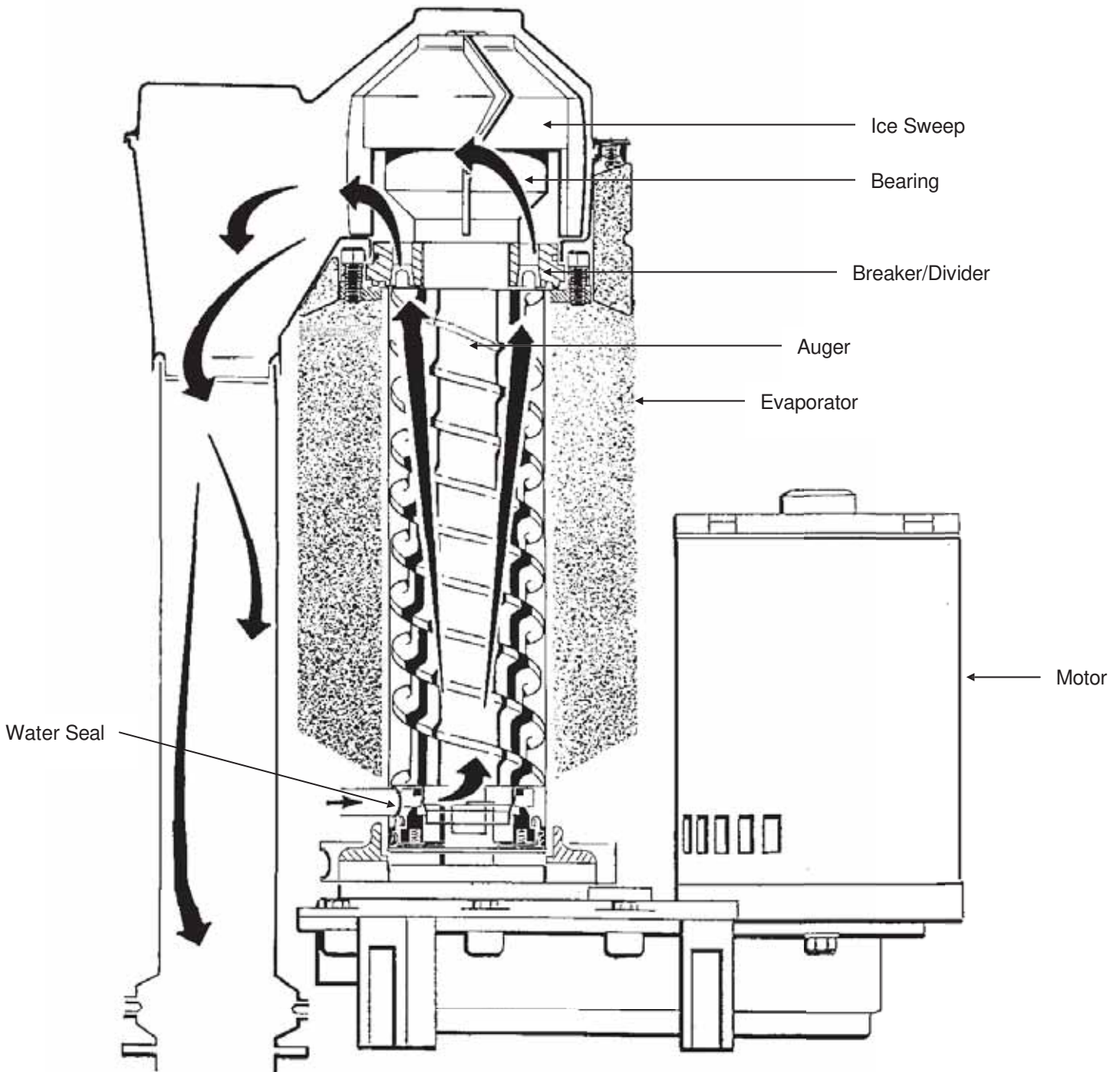

Electrical Sequence:

There are 7 indicator lights on the control board:

- **WTR-OK:** (Water OK) *Green*. Normal=Glowing. Glow when there is water in the reservoir.
- **PWR-OK:** (Power OK) *Green*. Normal=Glowing. Glows when the power board has power and is functional.
- **Service:** *Red*. Normally Off.
- **Freeze:** *Red*. Normally glowing when making ice.
- **Bin Full:** *Red*. Normally Off when making ice.
- **LED1:** *White*. Located next to the Control Board's Compressor Relay. Normally glowing when making ice.
- **LED2:** *White*. Located next to the Control Board's Auger Motor Relay. Normally glowing when making ice.

If the machine is switched **OFF** at the mode switch, but otherwise ready to go, switching the mode switch **ON** does the following:

- The **PWR-OK** light glows.
- If there is water in the float reservoir, the **WTR-OK** light glows.
- After 10 seconds the **Freeze**, **LED1** and **LED3** lights glow and the machine starts up.

Start Up:

- The compressor relay and auger motor relay become energized, connecting power to the windings of the auger motor and contactor coil.
- The contactor is energized, connecting power to the compressor, and the compressor starts.
- As ice is made it passes between the ice level sensors but because it is not a continuous stream it only interrupts the sensor's infrared beam momentarily. The bin full light remains off and the machine stays on until ice builds up in the bin and blocks the path between the sensors for 6 seconds or longer. When that occurs the bin full light glows and the machine shuts down.

Shut Down:

- The compressor relays opens, LED1 goes out.
- The compressor contactor opens.
- The auger motor stays on for 1 more minute, clearing out ice in the evaporator, and then
- The auger motor relay opens, LED3 goes out and the auger motor stops.

The compressor will not restart until 2 minutes or more have passed after last shutdown. If the path between the ice level sensors remains clear for more than 10 seconds the ice machine will restart.

Control Board Protection Devices:

- When the water level in the reservoir falls below the water level sensor's tip, the **WTR-OK** light goes out and the machine shuts down. When water refills the reservoir the **WTR-OK** light glows and the machine starts up again.
- If the auger drive motor currents becomes excessive the compressor and auger drive motor will be switched OFF and the **Service** light will blink. The control board will restart the auger drive motor in 4 minutes. If during the first 60 seconds after restart the auger motor current stays within limits, the compressor is restarted and the machine returns to normal operation. If the auger motor's current is excessive within 60 seconds after restart, the process will be repeated once more. If during that try the current is still excessive the machine shuts down and must be manually reset. The **Service** light will then be glowing continuously.

To Reset:

- Switch power to the unit off and then back on.

Other Protection Devices:

- If the **high pressure** control cut out switch opens the machine will stop immediately. It will automatically reset when the high pressure falls below its cut in point.
- If the **low pressure** control cut out switch opens the machine will stop immediately. It will automatically reset when the pressure rises above its cut in point.
- The **mode (ON-OFF)** switch is the manual control for the complete machine, but it is not a service disconnect.

Water

Water enters the machine through the 3/8 FPT at the rear of the cabinet, goes to the water reservoir which it enters through the float valve. The water then goes out the bottom of the reservoir tank to the bottom of the evaporator. Reservoir overflow or evaporator condensation is routed to the drain.

Water Level

The correct water level should be checked when the machine is making ice. Locate the water level in the reservoir, and compare it to the horizontal line molded into the side of the reservoir. The correct level should be between 1/8 inch above and 1/4 inch below the line. If needed, bend the float arm up or down to adjust the water level.

Water System

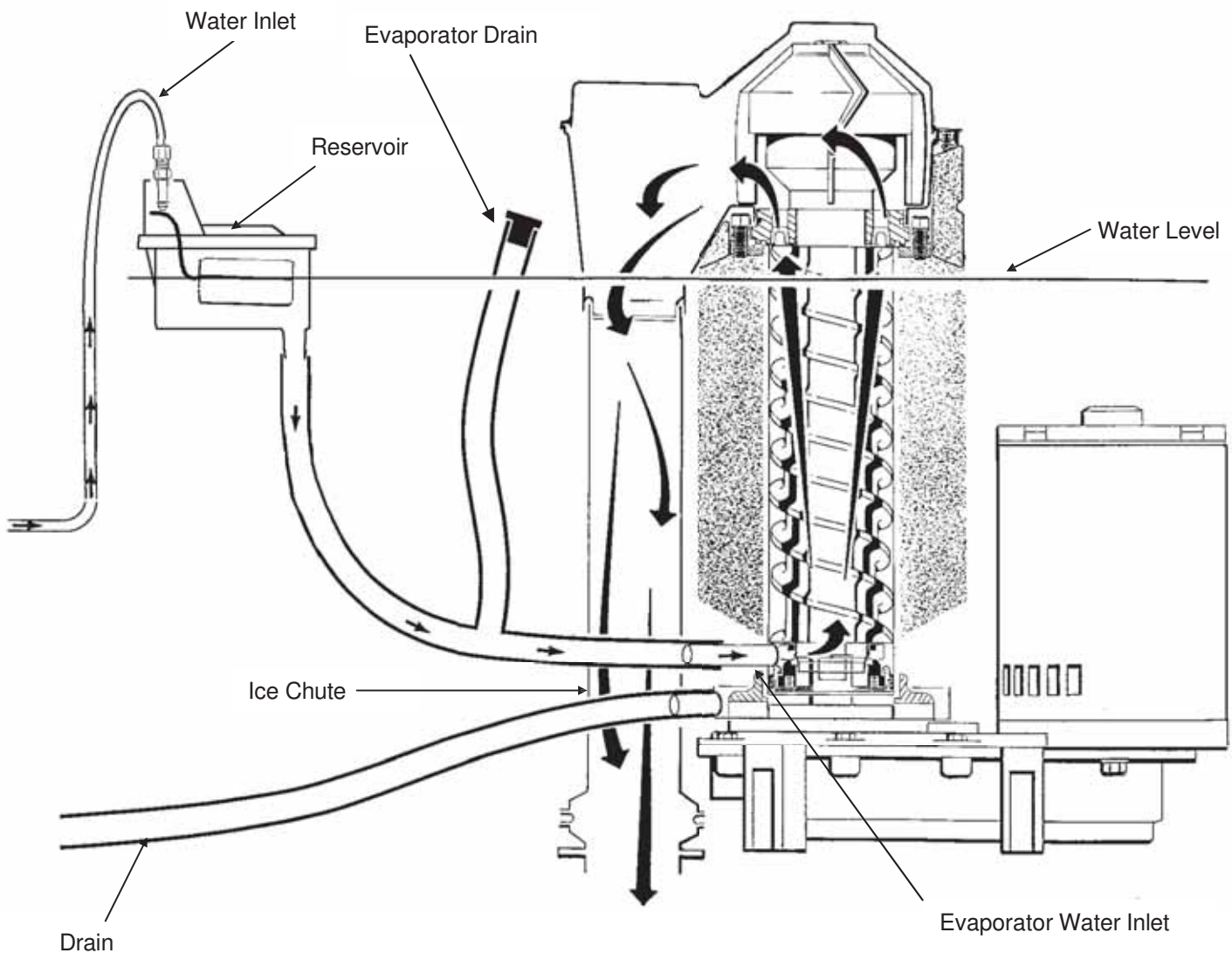

Beginning at the compressor, the refrigerant is compressed into a high temperature gas. The discharge line directs this gas to the condenser and to the head pressure control. At the remote condenser the gas is cooled by air and it then condenses into a liquid. This high pressure liquid then goes through the liquid line connection at the head pressure control. If the head pressure is high enough the liquid refrigerant will go through the valve and enter the receiver. From the receiver, the liquid refrigerant flows through the liquid line valve and then to the expansion valve.

The thermostatic expansion valve meters liquid refrigerant into the evaporator, the volume of liquid refrigerant depending upon the temperature of the evaporator; warmer evaporators get more refrigerant and colder evaporators get less. At the evaporator, the refrigerant enters an area of relatively low pressure, where it can easily "boil off" or evaporate. As it evaporates, it absorbs heat from the evaporator and whatever is in contact with it (such as the water inside it). After the evaporator, the refrigerant, now a low pressure vapor, goes through the suction line back to the compressor, where the cycle is repeated.

Refrigeration Schematic

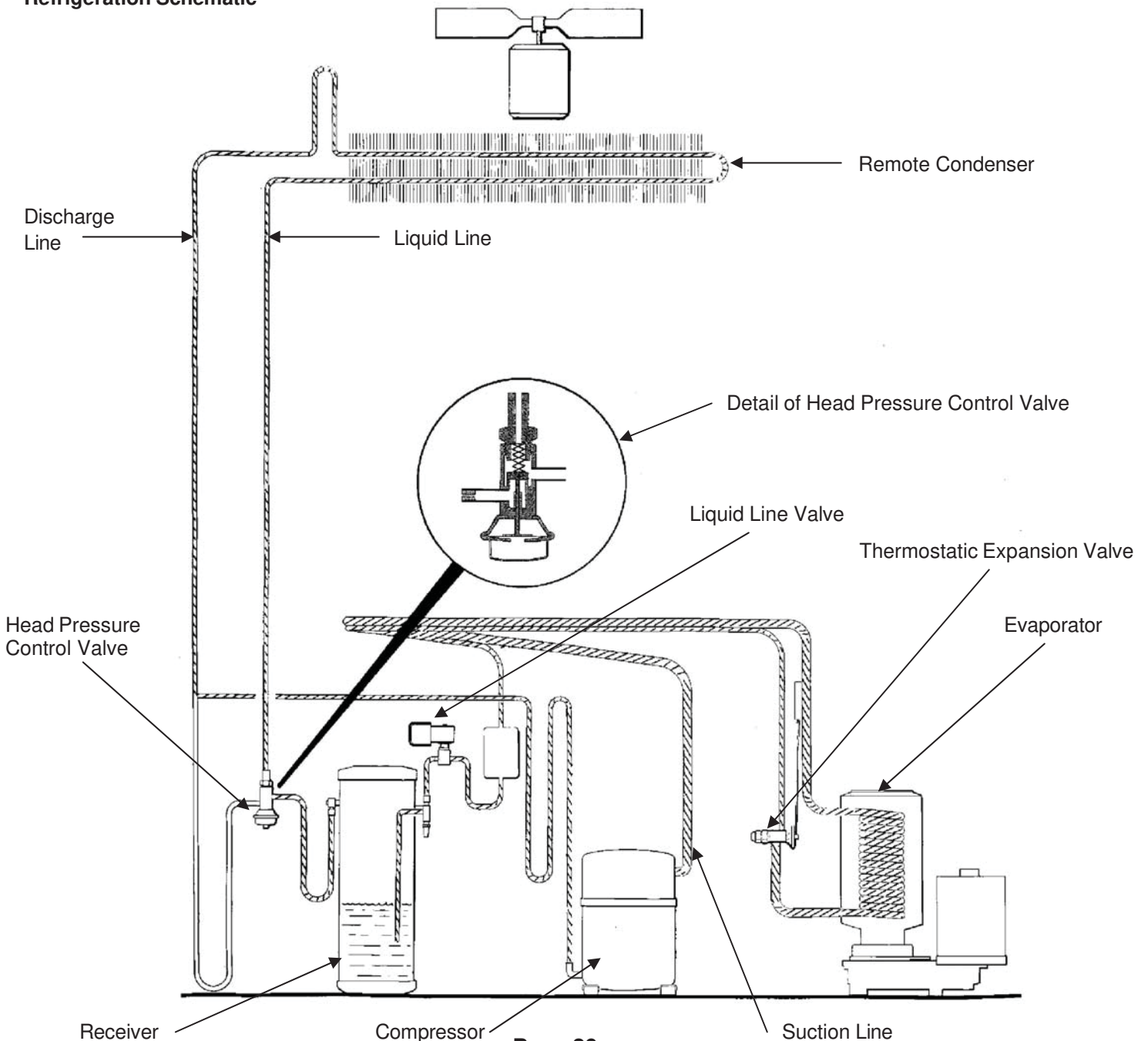

Low Condensing Temperature

The refrigeration system under low condenser air temperatures is much the same as it is under higher temperatures, with the exception that the resulting low head pressures cause the head pressure control to close off the liquid line between the condenser and the receiver.

This forces more refrigerant into the condenser (with a small amount of discharge gas going into the receiver to maintain pressure until the head pressure is built back up to 180 PSIG). At that pressure the valve opens up the liquid line from the condenser to the receiver.

Refrigeration Schematic

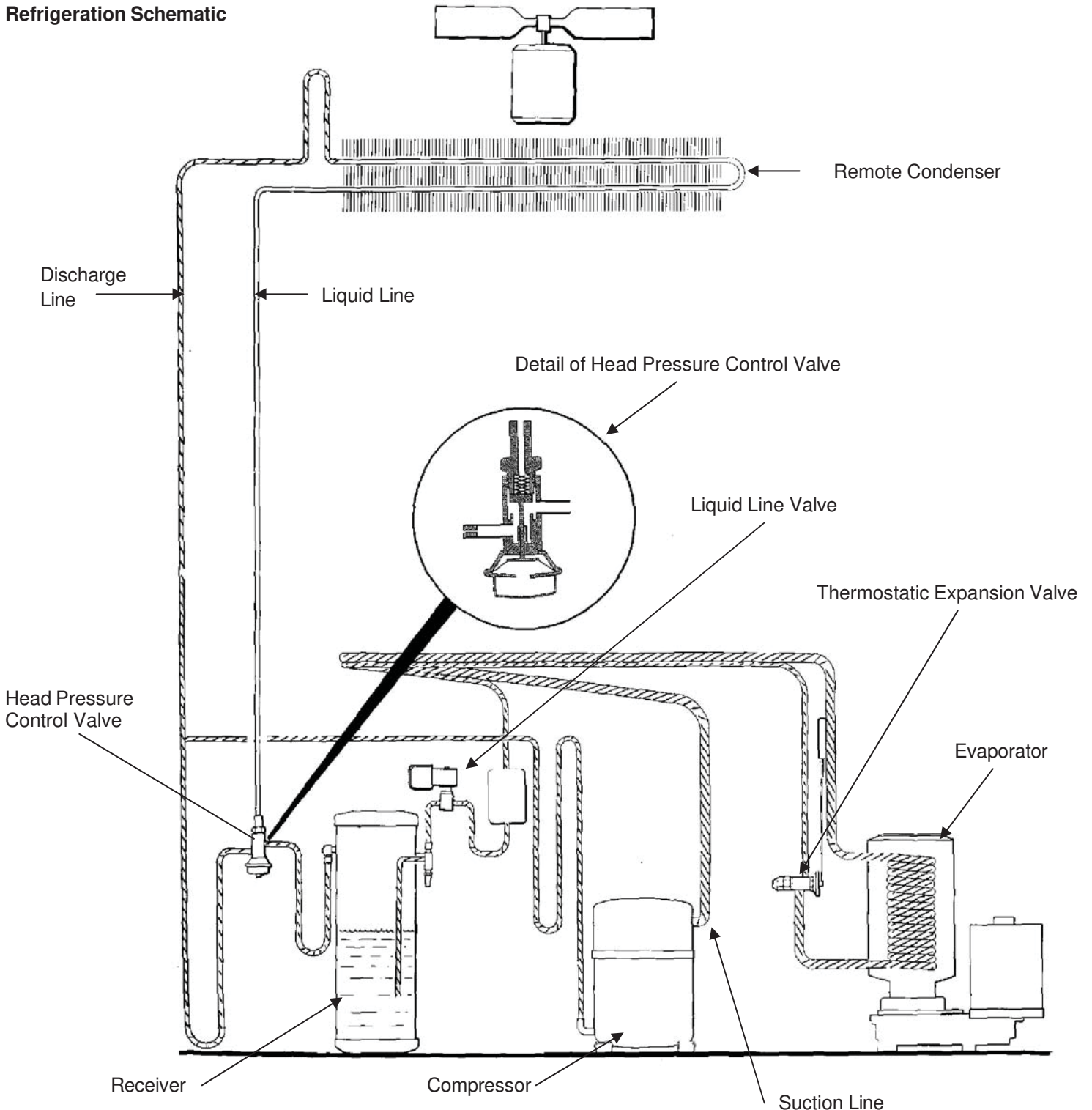

Pump Down

During the pump down cycle (usually initiated by the circuit board de-energizing the liquid line valve) the discharge gases flow through their normal path to the remote condenser, through the head pressure control and into the receiver. At this point the refrigerant flow is stopped by the closed liquid line valve.

This action forces the refrigerant into the receiver and keeps it out of the compressor. The pump down continues until the pump down control opens turning the compressor off.

Refrigeration Schematic

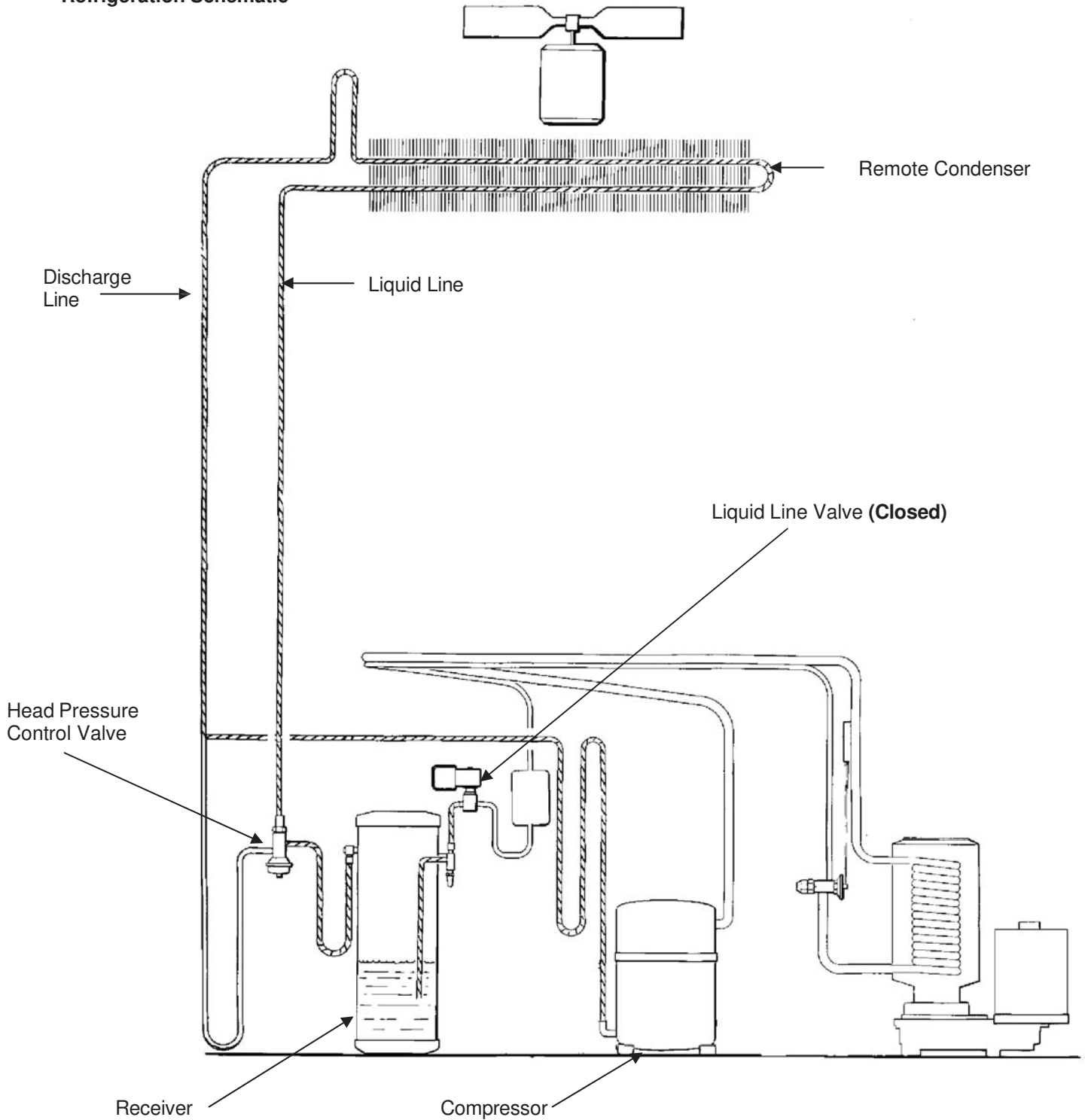

Beginning at the compressor, the refrigerant is compressed into a high temperature gas. The discharge line directs this gas to the condenser. At the condenser (air or water cooled) the gas is cooled by either air or water and then it condenses into a liquid.

This high pressure liquid then goes through the liquid line to the expansion valve. The thermostatic expansion valve meters liquid refrigerant into the evaporator, the volume of liquid refrigerant depending upon the temperature of the evaporator.

At the evaporator, the refrigerant enters an area of relatively low pressure, where it can easily “boil off” or evaporate. As it evaporates, it absorbs heat from the evaporator and whatever is in contact with it (such as water inside it). After the evaporator, the refrigerant, now a low pressure vapor, goes through the suction line back to the compressor, where the cycle is repeated.

Typical Low Side Pressure:

Air Cooled: (R404A-R449A)	34-38 PSIG
Water Cooled: (R404A-R449A)	32 PSIG
Air Cooled: (R290)	26-28 PSIG
Water Cooled: (R290)	26 PSIG

Typical Discharge Pressure:

Air Cooled: (R404A-R449A)	220-275 PSIG
Water Cooled: (R404A-R449A)	245 PSIG
Air Cooled: (R290)	155-200 PSIG
Water Cooled: (R290)	165 PSIG

Typical Compressor Amp Draw:

GEM0450/MFI0500	115/60/1	7.8 Amps
GEM0650/MFI0800	115/60/1	11.9 Amps
GEM0655/MFI0805	230/50/1	6.0 Amps
GEM0956/MFI1256	208-230/60/1	7.0 Amps
GEM0955/MFI1255	230/50/1	8.86 Amps
GEM1306A/MFI1506A	208-230/60/1	9.4 Amps

Typical Auger Drive Motor Amp Draw:

GEM0450/MFI0500	115/60/1	4.6 Amps
GEM0650/MFI0800	115/60/1	4.6 Amps
GEM0655/MFI0805	230/50/1	2.0 Amps
GEM0956/MFI1256	208-230/60/1	2.4 Amps
GEM0955/MFI1255	230/50/1	2.3 Amps
GEM1306/MFI1506	208-230/60/1	2.4 Amps

High Pressure Cut Out- Automatic Reset: 450 PSIG (R404 & R449) 350 psig (R290)

Low Pressure Cut Out- Automatic Reset: 15 PSIG

Refrigerant Charge: R404A

<u>GEM0450/MFI0500</u>		<u>GEM1306/MFI1506</u>	
Air Cooled:	22 ounces	Air Cooled:	30 ounces
Water Cooled:	18 ounces		
<u>GEM0650/MFI0800</u>		<u>GEM0655/MFI0805</u>	
Air Cooled:	24 ounces	Air Cooled:	24 ounces
Water Cooled:	19 ounces	Water Cooled:	19 ounces
<u>GEM0956/MFI1256</u>		<u>GEM0955/MFI1255</u>	
Air Cooled:	30 ounces	Air Cooled:	30 ounces
Water Cooled:	22 ounces	Water Cooled:	22 ounces

Typical Low Side Pressure:

Remote: (R404A)	28-35 PSIG
(R449A)	29-36 PSIG

Typical Discharge Pressure:

Remote: (R404A)	220-275 PSIG
(R449A)	180-275 PSIG

Typical Compressor Amp Draw:

GEM0650	115/60/1	11.9 Amps
GEM0956/MFI1256	208-230/60/1	7.0 Amps
GEM1306/MFI1506	208-230/60/1	10.5 Amps
GEM2006/MFI2306	208-230/60/1	14.9 Amps

Typical Auger Drive Motor Amp Draw:

GEM0650	115/60/1	4.6 Amps
GEM0956/MFI1256	208-230/60/1	2.4 Amps
GEM1306/MFI1506	208-230/60/1	2.4 Amps
GEM2006/MFI2306	208-230/60/1	2.4 Amps

High Pressure Cut Out- Automatic Reset: 450 PSIG

Pump Down Cut Out- Automatic Reset: 15 PSIG

Refrigerant Charge: R404A

GEM0650	Remote	208 ounces
GEM0956/MFI1256	Remote	208 ounces

Refrigerant Charge: R449A

GEM0650R49	Remote	201 ounces
GEM0956R49	Remote	201 ounces
GEM1306R49	Remote	201 ounces
GEM2006R49	Remote	208 ounces
MFI0800R49	Remote	201 ounces
MFI1256R49	Remote	201 ounces
MFI1506R49	Remote	201 ounces
MFI2306R49	Remote	208 ounces

ICE Machine and/or Bin/Dispenser Cleaning and Sanitizing Instructions

Cleaning should be scheduled at a minimum of twice per year.

Sanitizing should be performed after each cleaning or more frequently as required.

Note: Electrical power will be ON when performing the following cleaning instructions.

The cleaning and sanitizing of any commercial ice machine are important procedures all operators need to have in their preventive maintenance protocol. While similar, these two procedures are uniquely different and accomplish different things. Cleaning or de-liming, dissolves the mineral deposits on the evaporator and removes scale, calcium and other mineral buildup. Sanitizing disinfects the machine and removes microbial growth including mold and slime.

In either case, it is important to use solutions that do not harm the ice machine. Never use cleaning or sanitizing solutions that contain Nitric Acid, Sulfuric Acid, Hydrochloric Acid, Carboric Acid, Acetic Acid, diluted Acetic Acid or non-food-grade vinegar (concentration of acetic acid greater than 6% and does not contain enzymes created in processing) or any chlorine-based solution such as bleach, chlorine dioxide or any type of salts such as potassium chloride (potassium salts) or sodium chloride. Check the label or the manufacturer's Material Safety Data Sheet (MSDS) to be sure. These chemicals can attack the surface of the evaporator as well as other metal components causing corrosion and flaking. Reverse Osmosis (RO) water can be very acidic and can attack the evaporator and other metal in the ice machine. Because the RO process removes all minerals and metals from the water it can promote the faster growth of microbial, mold and slime. If RO water is used, Ice-O-Matic recommends the water pH is verified to be a neutral 7.0 to minimize the corrosive effects. Incorrect cleaners, sanitizers, and RO water that does not have a neutral pH could void the machine's warranty.

Cleaning

Prior to Cleaning the ice machine and/or Bin/Dispenser, perform the following:

1. Remove the ice machine front panel.
2. Turn the machine "OFF" at the ON/OFF selector switch.
3. Remove all ice in the storage bin. (**Required for cleaning and/or sanitizing**)

Cleaning Instructions-Ice Machine

1. Remove the cover from the water reservoir and block up the float.
2. Drain the water reservoir and freezer assembly using the drain tube attached to the freezer water inlet. Return the drain tube to its normal position and replace the end cap.
3. Add recommended amount of approved nickel safe ice machine cleaner (diluted per manufacturer's instructions) to the water trough. (Reference cleaner Manufacturer's instructions on the package)
4. Slowly pour the cleaning solution into the water reservoir until full. Wait 15 minutes, then switch the ON/OFF switch to the ON position.
5. As the ice machine begins to use water from the reservoir, continue to add more cleaning solution to maintain a full reservoir.
6. After all of the cleaning solution has been added to the reservoir, and the reservoir is nearly empty, switch the ON/OFF switch to the OFF position.
7. Drain the water reservoir and freezing assembly using the drain tube attached to the to the freezer water inlet. Return the drain tube to its normal position and replace the drain plug end cap. Wash and rinse the water reservoir.
8. **Sanitizing the Ice Machine is required after cleaning per Sanitizing Instructions**

Cleaning Instructions-Storage Bin/ Dispenser

1. Open the bin door and remove all of the ice in the storage bin, store the ice in a clean container for reuse or discard.
2. Add recommended amount of approved nickel safe ice machine cleaner (diluted per manufacturer's instructions) (Reference cleaner Manufacturer's instructions on the package)
3. Thoroughly wash all surfaces within the bin, this includes the bin door, bin walls, window track and snout area with soap and water and rinse. Note: An extended handle soft bristle brush may be required.
4. Allow the mineral deposits to absorb the cleaner for approximately 15 minutes to remove and loosen the mineral deposits. Note: This includes the bin drain.
5. Thoroughly wash all surfaces within the bin, this includes the bin door, bin walls, window track and snout area with soap and water and rinse. Note: Repeat Steps 3, 4 and 5 as required.
6. **Sanitizing the Storage Bin/Dispenser is required after cleaning per Sanitizing Instructions**

Sanitizing

Prior to Sanitizing the ice machine and/or Bin/Dispenser, perform the following:

1. Remove the ice machine front panel.
2. Turn the machine "OFF" at the ON/OFF selector switch.
3. Turn OFF the potable water supply to the ice machine.
4. Remove all ice in the storage bin. (**Required for cleaning and/or sanitizing**)

Sanitizing Instructions-Ice Machine

1. Use an EPA approved food equipment sanitizer at the solution mix recommended by the sanitizer manufacturer.
2. Slowly pour the sanitizer solution into the water reservoir until full. Wait 15 minutes, then switch the ON/OFF switch to the ON position.
3. As the ice machine begins to use water from the reservoir, continue to add more sanitizing solution to maintain a full reservoir.
4. After all of the sanitizing solution has been added to the reservoir, and the reservoir is nearly empty, switch the ON/OFF switch to the "OFF" position.
5. Drain the water reservoir and freezing assembly using the drain tube attached to the to the freezer water inlet. Return the drain tube to its normal position and replace the drain plug end cap. Wash and rinse the water reservoir. During this time, wipe down all other ice machine splash areas. Inspect to insure that water transport system components are in the correct position.
6. Place the ON/OFF switch to the "ON" position and replace the front panel.
7. Continue ice making for at least 15 minutes to flush out any cleaning or sanitizing solution.
8. **Remove and discard all ice in the storage bin. DO NOT USE any ice produced from the cleaning solution.**

Sanitizing Instructions- Bin/ Dispenser

1. Use an EPA approved food equipment sanitizer at the solution mix recommended by the sanitizer manufacturer.
2. Sanitize the bin interior, this includes the bin door, bin walls, window track and snout area with an approved sanitizer using the directions for that sanitizer. Note: This includes the bin drain.
3. **Remove and discard all ice in the storage bin. DO NOT USE any ice produced from the cleaning solution.**

Common Questions**•Ice-O-Matic Ice Machine/Bin Cleaning**

Cleaning or de-liming an ice machine refers to the process of removing mineral buildup and scale from the evaporator and other components. Ice-O-Matic recommends cleaning the ice machine at least every 6 months. More frequent cleaning may be needed depending on water quality and filtration system used. It is the responsibility of the operator to determine the optimal frequency for their particular environment. Cleaning will not remove microbial, mold, or slime. The machine should always be sanitized after cleaning.

Ice-O-Matic recommends a "nickel-safe" cleaner such as Nu-Calgon or equivalent. Typically the chemical composition is as follows:

- Water 53% to 82%
- Phosphoric Acid 15% to 40%
- Citric Acid 3% to 7%



WARNING

Ice Machine Cleaner contains acids.
KEEP OUT OF THE REACH OF CHILDREN
Refer to ice machine cleaner manufactures
emergency instructions on container label.

Ice-O-Matic recommends cleaning be done by a trained technician and that they follow detailed steps as prescribed in the Technical Service Manual.

Most cleaners list in their instructions an ounces to a gallon mixture for proper level of solution. Pouring undiluted cleaner directly into the machine will not give proper dilution level. Ice-O-Matic recommends mixing in a plastic container before pouring into trough.

•Ice-O-Matic Ice Machine/Bin/Dispenser Sanitizing

Ice-O-Matic recommends sanitizing or disinfecting an ice maker a minimum of every six months. More frequent sanitizing may be needed if the machine is in a high yeast environment or if RO water is being used. It is the responsibility of the operator to determine the optimal frequency for their particular environment.

Ice-O-Matic recommends an EPA approved sanitizer such as Nu-Calgon IMS-II or equivalent. Sanitizing is a simple matter of running the EPA approved sanitizer through the ice machine/bin/dispenser and wiping down surfaces with the sanitizer. If being done at the same time as the cleaning process, sanitizing must be done after the cleaning process. Follow the process as prescribed in the Owner's Manual. Note: this process requires the ice be removed from the bin.

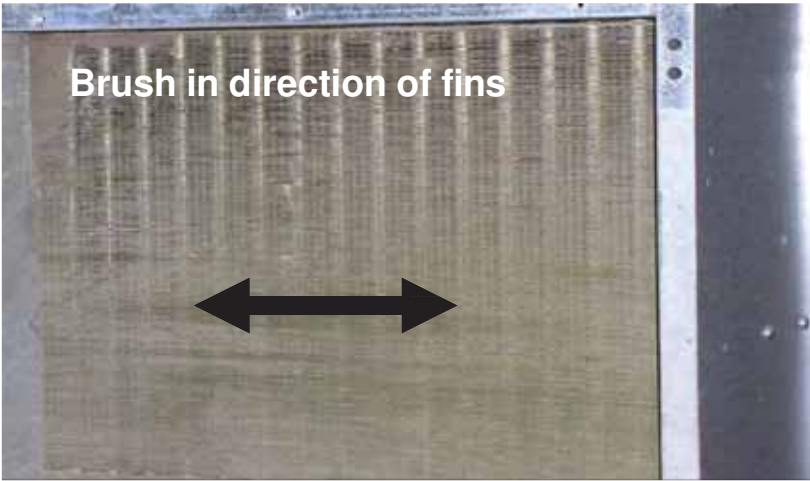

- Clean the condenser: the condenser may appear to be clean on the surface, but it can still be clogged internally. Check with a flashlight from the front to see if light can be seen through the condenser fins.

The condenser coil must be kept clean. The condenser can be cleaned with compressed air or by using a brush.

If a brush is used, brush in the direction of the fins taking care not to bend or distort the fins. Use a soft bristle nylon brush.

If the condenser fins are bent or distorted, this will restrict the airflow through the condenser and the fins will need to be straightened with a fin comb.

When cleaning the Condenser, check the fan blade for cleanliness and for balance. Balance is checked by spinning the blade by hand and looking for any wobble. Pull on the shaft in several directions to check the bearings of the motor.

The fins of the remote condenser require periodic cleaning.

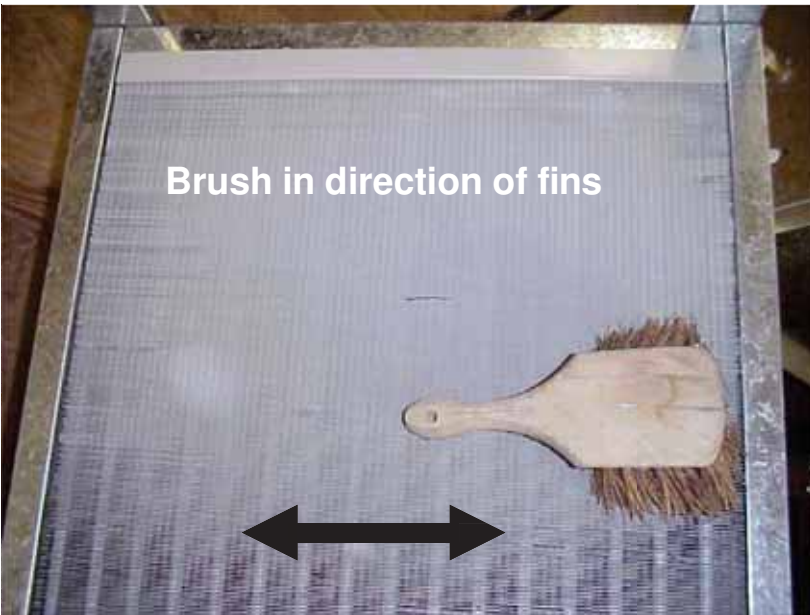

At 6 month intervals the fins on the inlet side of the condenser (bottom as shown) should be brushed free of dust and dirt. Brush in the direction of the fins as noted by the arrows.

Additionally look through the fins, using a flashlight if required, to insure there is no other blockage obstructing air flow between the fins.

If the air flow appears to be blocked, blow out the condenser using CO2 gas.

Caution: Disconnect electrical power before servicing this equipment.

Caution: Protective eye wear and gloves should be worn when cleaning the condenser.

Clean the air cooled condenser:

Air flow on this model is from front to back, so the inside of the ice machine will have to be available to clean the air cooled condenser. Use a vacuum cleaner or coil cleaner if needed. DO NOT use a wire brush.

- **Disconnect electrical power**, and remove the air filter if applicable. The filter may be cleaned or replaced.
- Clean the condenser: the condenser may appear to be clean on the surface, but it can still be clogged internally. Check with a flashlight from the front to see if light can be seen through the condenser fins.

GEM0956

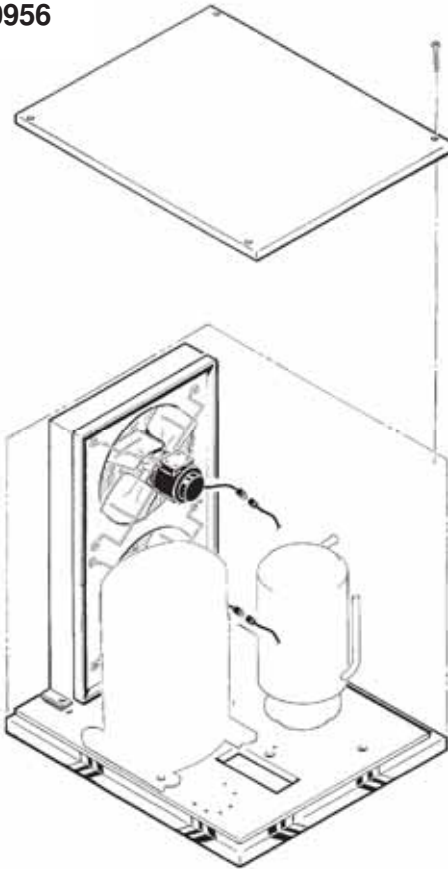

- Step 1. Remove the Top Panel
- Step 2. Remove two screws and unplug fan motors.
- Step 3. Pull fan motor assembly up and to the right to remove.
- Step 4. Clean the condenser.

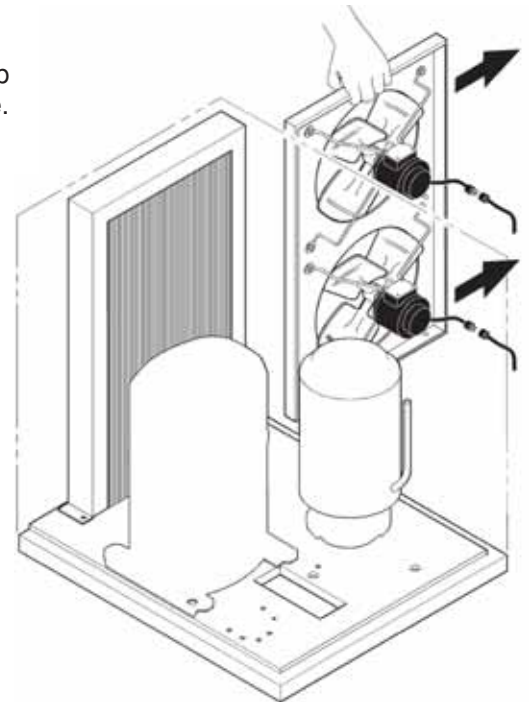

GEM0650

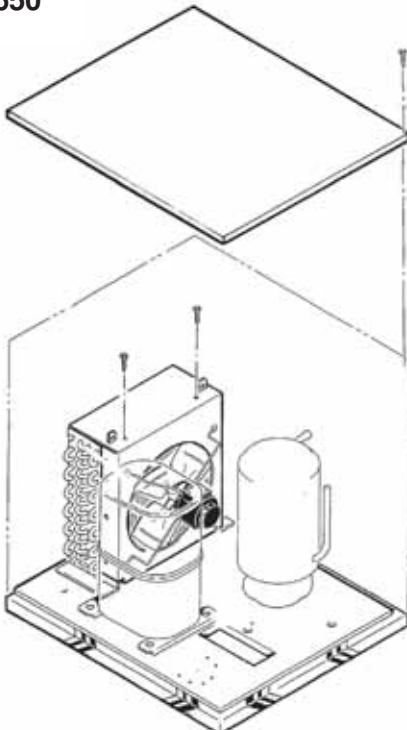

- Step 1. Remove the Top Panel
- Step 2. Remove the top portion of the fan shroud.
- Step 3. Clean the condenser.

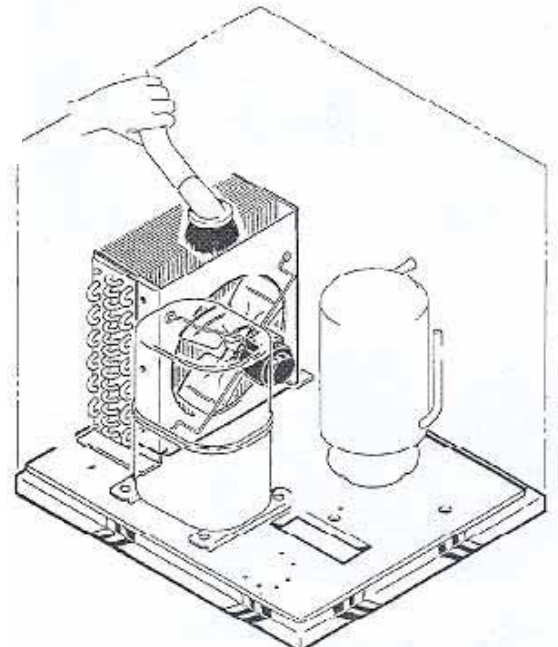

Bearing Maintenance:

The bearing in the breaker should also be checked at least **two (2)** times per year. Switch the machine **OFF** and check the bearing.



1. Remove the chute cover.



2. Unscrew the ice sweep



3. Removing the water shed and unscrewing the breaker cover.
Note: Left Hand Threads



4. Unscrewing the auger stud

5. Inspect the bearing. There should be plenty of grease in sight. If grease is needed the bearing and breaker should be removed to check the action of the bearing. It should rotate freely.

6. To remove the breaker, remove the lower ice chute then take out all four (4) Allen head cap screws and pull the breaker off the auger and evaporator.

7. If the bearing only needs grease, inject grease into the bearing using a grease needle.



See Removal and Replacement Section to replace bearings and seals.

Bin Control Sensor:

The bin control uses devices that sense light, therefore they must be kept clean enough so that they can “see”.

At least twice a year, remove the bin control sensors from the base of the chute, and wipe the inside clean, as illustrated.

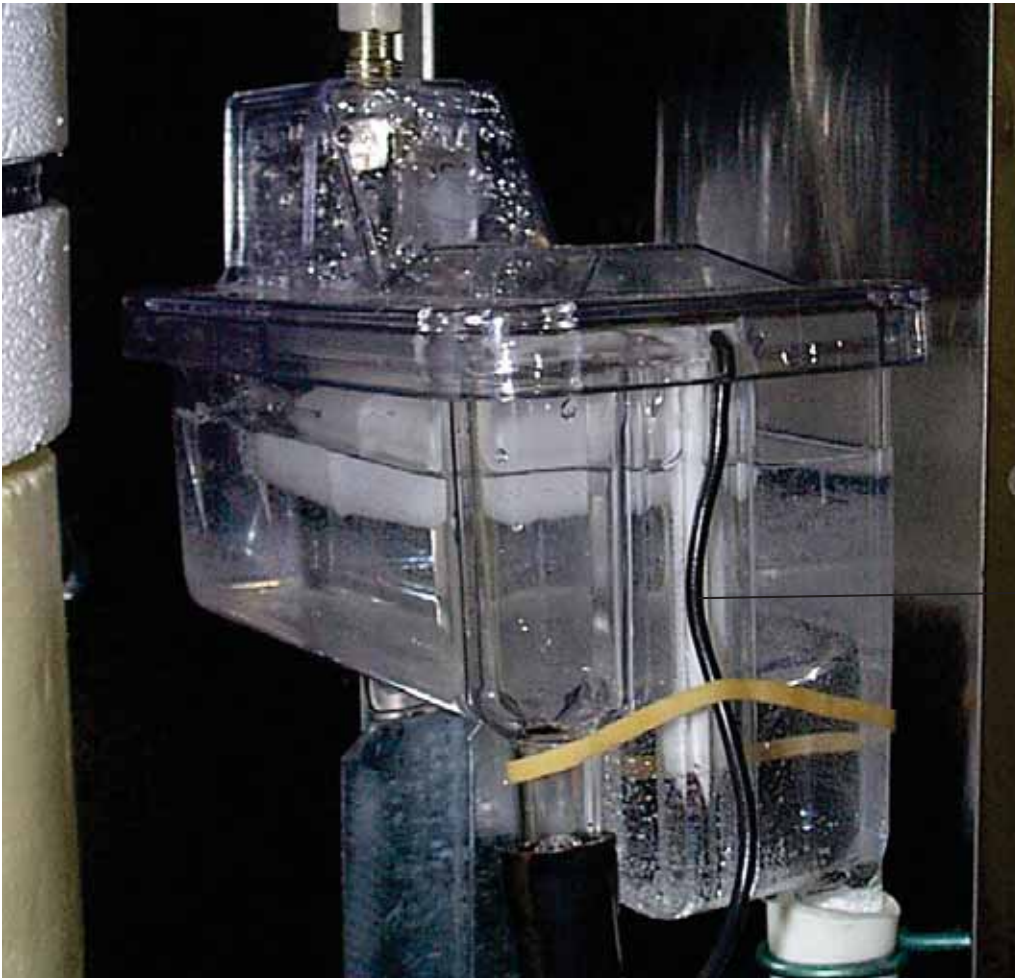
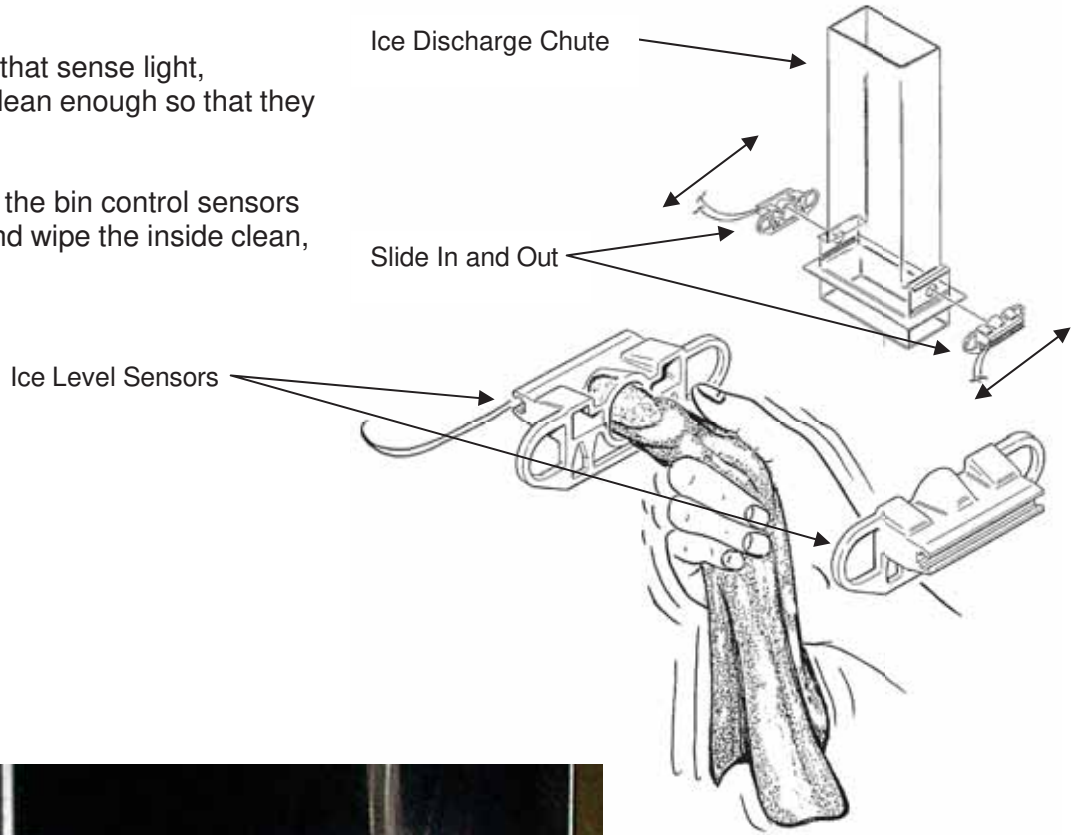

Water Sensor:

The ice machine uses a probe in the water reservoir to determine if there is water.

At least twice a year remove the probe from the reservoir and wipe the tip clean of mineral build-up.



Clean the probe's tip with ice machine cleaner and a soft cloth.

Auger:

In some areas, the water supply to the ice machine will contain a high concentration of minerals, and that will result in an evaporator and auger becoming coated with these minerals, requiring a more frequent removal than twice per year. If in doubt about the condition of the evaporator and auger, the auger can be removed so the parts can be inspected.

Note: Water filters can filter out suspended solids, but not dissolved solids. "Soft" water may not be the complete answer. Check with a water treatment specialist regarding water treatment.

For more information on removal of these parts, see **Removal and Replacement**.

1. **Disconnect electrical power to the ice machine.**
2. **Turn off the water supply to the ice machine.**
3. To remove the auger, remove the front and top panels.
4. Push back the bail clamp holding the ice chute cover to the ice chute, and remove cover.
5. Remove ice chute from evaporator.
6. Remove four (4) Allen screws holding breaker to evaporator.
7. Drain the evaporator by lowering and uncapping the evaporator drain hose.
8. Pull up to remove the auger. After the auger has been removed, allow the auger to dry: if the auger is not bright and shiny, it must be cleaned.
9. Clean the auger and evaporator as required. **DO NOT HONE THE EVAPORATOR.**
10. Replace the water seal.
11. Reverse to reassemble.

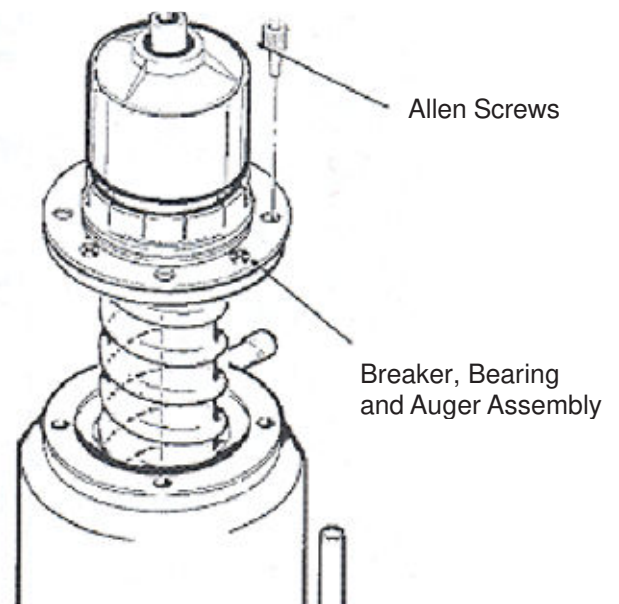
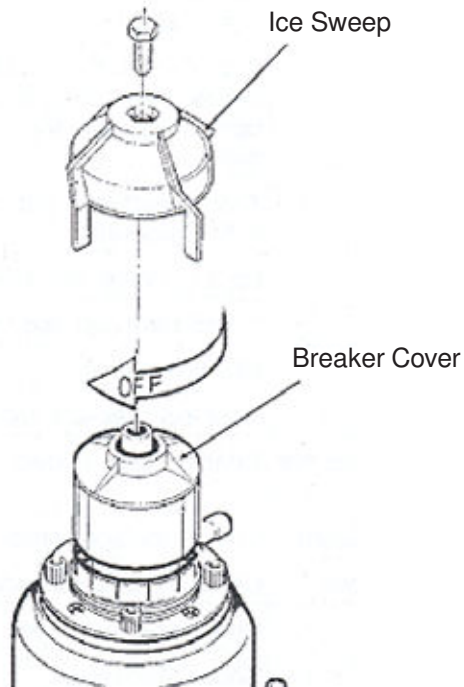

Symptom

No ice is made nothing operates.

Possible Cause

- Unit off due to no power
- Unit off due to master switch in **OFF** position
- Unit off due to low water level
- Unit off due to ice level sensors. (Photo Eyes) blocked.
- Unit off due to scale on water level sensor.
- Unit off due to high pressure control open.
- Auger motor hums but does not turn.
- Unit is shut down.
- Low pressure control open.
- No power to circuit board.
- Circuit board gear motor relay will not close.

Probable Correction

- Restore Power
- Switch master Switch to **ON**
- Check water supply, filter strainer, float valve. Correct water supply.
- Check/clean ice level sensors.
- Clean water level sensor.
- Check for water interruption (water cooled) of fan motor failure.
- Auger can't turn. Circuit board has not yet shut it down.
- Circuit board has shut ice machine down due to high auger motor amp draw. Check for cause of high amp draw, including bearings, gear motor condition and scale on auger and in evaporator.
- Auger not turning due to: motor failure; auger relay failure on circuit board; or or gears stripped. Check drive train.
- TXV restricted or not metering. Check bulb temperature.
- Lack of refrigerant, check for leak.
- Check for a restricted system.
- Check harness
- Hi or low pressure cut outs open.
- Check/replace board.
- Check/replace contactor.
- Check start capacitor.
- Check start relay.
- Check compressor windings.

No ice, auger motor is turning.

- Compressor contactor coil is open.
- Compressor will not start.

Symptom

Unit makes ice, but very slowly

Possible Cause

- High discharge pressure because of a dirty condenser.
- Low capacity because the auger and evaporator are coated with mineral scale.
- Low suction pressure due to low refrigerant charge.

Probable Correction

- Clean filter and condenser.
- Clean the water system.
- Locate leak. Recover the refrigerant, repair leak, replace drier, evacuate and weigh in the nameplate charge.

Water leak.

- Drain plugged up.
- Tubing cracked
- Condensation on drain tubing.
- Water hose off
- Reservoir cover off.
- Reservoir cracked.
- Evaporator water seal leaks.

- Clean out drain.
- Replace tubing.
- Insulate tubing.
- Reattach hose.
- Return cover to reservoir.
- Replace reservoir.
- Check base of evaporator and drip pan. If the seal leaks, shut off the water, remove the auger and replace the water seal. Check the gear motor for water infiltration.

Excessive water use.

- Water cooled model, water regulating valve not adjusted properly.
- Reservoir float valve leaks thru.
- Water cooled model, overcharged with refrigerant.
- Water cooled model, condenser coated with minerals.

- Adjust to 245 PSIG discharge pressure.
- Replace float valve or seat.
- Recover and weigh refrigerant. Weigh in correct charge.
- Acid clean the water cooled condenser.

Excessive ice meltage.

- Bin drain clogged
- Improper installation of drains, they are connected.
- Poor fit between bin door and door frame.

- Clean out bin drain.
- Drains must be separate.
- Adjust or replace.

Machine makes too much noise.

- Evaporator coated internally with minerals.
- Motor bearing dry.

- Clean with ice machine cleaner.
- Oil or replace motor.

The Control System consists of:

- Control Board
- Water Sensors
- Ice Sensors
- High Pressure Cut Out
- Low Pressure Cut Out

If the unit is **OFF**, check the **control board**:

1. Is the Power **OK** light on? If not check power to the unit. If it has power, and the Power **OK** light is **not** on, check the high pressure and low pressure cut outs. If they are both closed, replace the board. If the **POWER OK** light is **ON**, go to the next step.
2. Is the Water **OK** light on? If it is, go to the next step. If not, check the water level in the reservoir. If there is water in the reservoir, check that the water sensor is plugged in. To check the water sensor:
 - a. Unplug the water sensor.
 - b. Pull the water sensor from the reservoir.
 - c. Place one ohmmeter lead on the sensor's plug and the other on the sensor's tip. The meter should show nearly zero (0) resistance. If it reads infinite resistance, check the tip for corrosion. If it is clean and still reads open, replace the sensor.
OR, connect a copper wire to the wire where the water sensor plugs into and place the other end in the water. The **WATER OK** should go **ON**. If it does not, replace the board.
3. **Ice sensor Check.** Is the **BIN FULL** light **OFF**? If it is **OFF** and the **SERVICE** light is **OFF** and the unit is not running, replace the control board.
 - a. If it is **OFF** and the auger motor is running but the compressor is not, check the compressor contactor coil.
 - b. If it is **ON**, the ice sensors may be blocked. Remove them and check for mineral scale.
4. **High pressure** cut out check.
 - a. Disconnect electrical power.
 - b. Pull the wires off the high pressure cut out.
 - c. Use an ohmmeter to determine if the switch is **OPEN**. If it is, check the discharge pressure. If the discharge pressure is less than 300 PSIG, replace the high pressure cut out.
 - d. If the high pressure cut out is open and the system has high discharge pressure, check for the cause.
5. **Low pressure** cut out check.
 - a. Disconnect electrical power.
 - b. Pull the wires off the low pressure cut out.
 - c. Use an ohmmeter to determine if the switch is **OPEN**. If it is, check the suction pressure. If the suction pressure is greater than 20 PSIG, replace the low pressure cut out.
 - d. If the low pressure cut out is open and the system has low suction pressure, check for the cause.

Water Reservoir:

1. Disconnect electrical power supply.
2. Shut off water supply to the ice maker.
3. Remove the front panel.
4. Disconnect water inlet tube from reservoir inlet fitting.
5. To remove float valve, push in "locking tabs" as shown and pull float up. Note: The plunger/seat is available separately as a part.
6. To remove reservoir, pull up and remove water sensor.
7. Disconnect water outlet tubes.
8. Remove mounting screws from reservoir bracket, and remove reservoir from ice maker.
9. Reverse to reassemble.

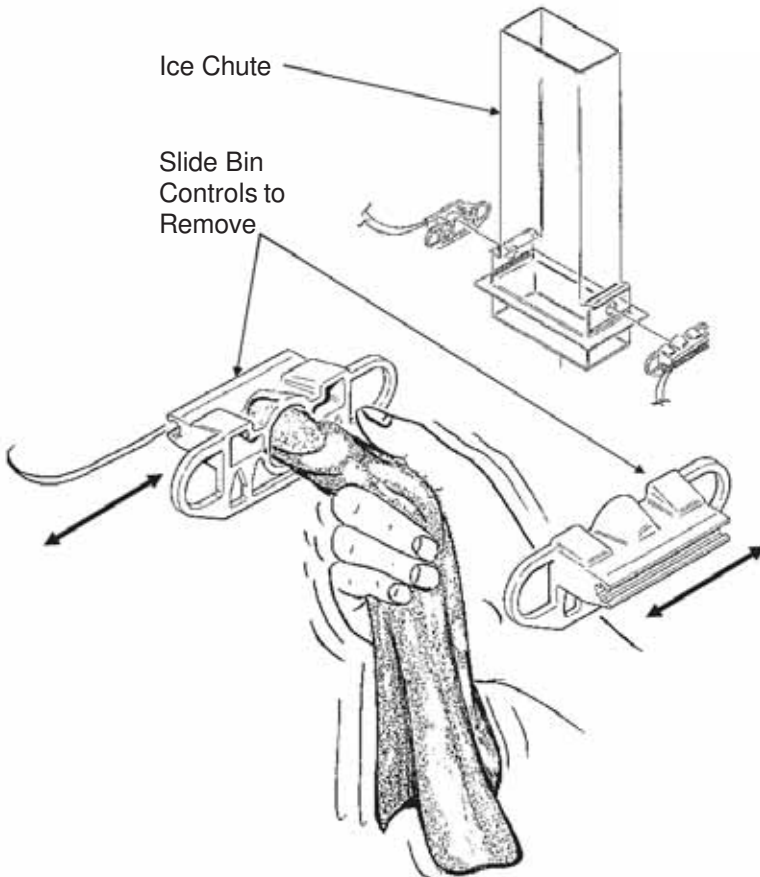
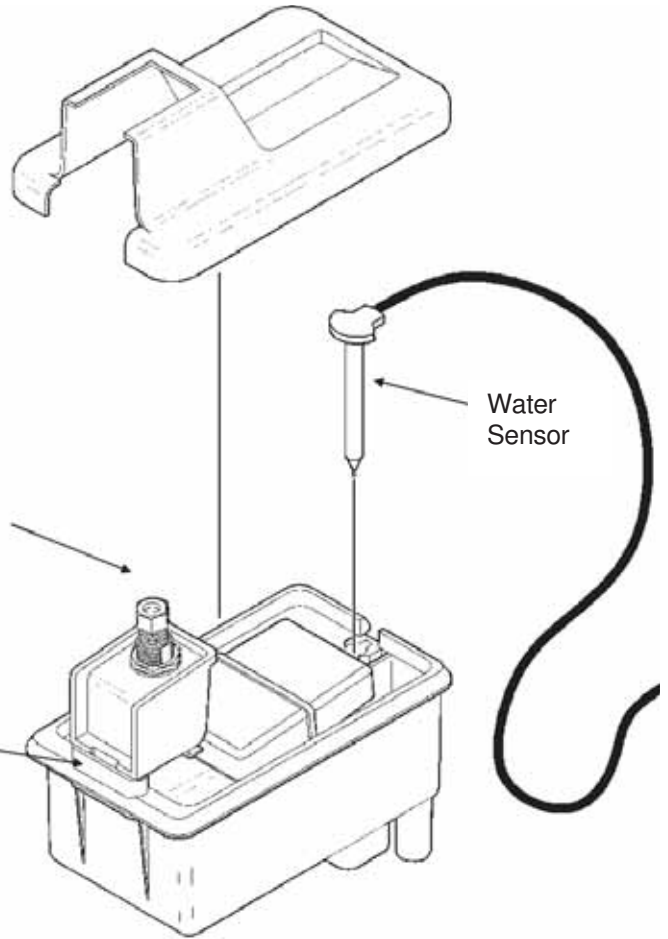

Bin Controls (Ice Level Sensors)

1. Disconnect electrical power supply.
2. Remove the front panel.
3. Remove the control box cover.
4. Locate ice chute, at the base of the chute, in front of and behind it are two plastic bin control mounts.
5. Slide each bin control to the left, and disconnect the electrical leads connecting the bin control to the circuit board.
6. Reverse to reassemble, be certain that the bin controls are aligned so that the ice level sensors are visible (centered) through the holes in the ice chute.

Note: Removal of the auger, water seal, evaporator and gear motor must begin at the top of the assembly.

To Remove the Breaker Bearing Assembly:

1. Disconnect electrical power.
2. Remove panels.
3. Push back bail clamp and remove ice chute cover.
4. Unscrew and remove ice sweep.
5. Lift up and remove ice chute.
6. The breaker may be removed from the auger and evaporator without disturbing the auger.
 - a. Unscrew breaker cover from breaker (**Note: Left Hand Threads**)
 - b. Unscrew auger stud from top of auger. (Fig. 1)
 - c. Unscrew four (4) Allen head cap screws holding breaker to evaporator. (Fig 2)
 - d. Lift up, and remove breaker/bearing assembly from auger and evaporator. (Fig 3)
7. Service the bearing. Check for rust, rough spots and damage.
 - a. The bearing is pressed into the breaker, to remove the bearing and replace it, an arbor press is needed.
 - b. Replace lower seals before installing new bearing in breaker. **Note:** Seals must be pressed in with a tool pushing against the outer edge only, they will not install by hand.
 - c. Replace parts as required. Re-grease bearings with Ice-O-Matic PN6051062-01 bearing grease.
 - d. Replace top seal and check the O-Rings, replace if cut or torn.
8. Reverse to reassemble: Specific tools and materials are required to install properly.
 - a. Add food grade grease such as Ice-O-Matic PN6051036-01 to the seal area before installing on the auger.
 - b. Check the seal to shaft areas for cuts or rough spots, none are permitted.



Fig. 1

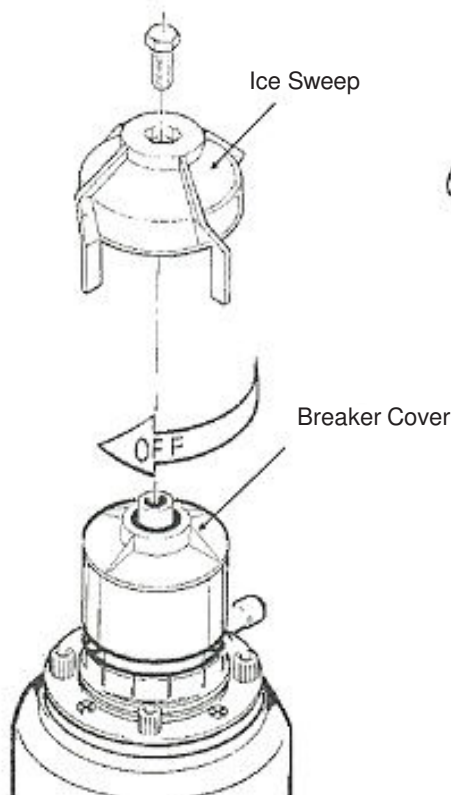

Fig. 2

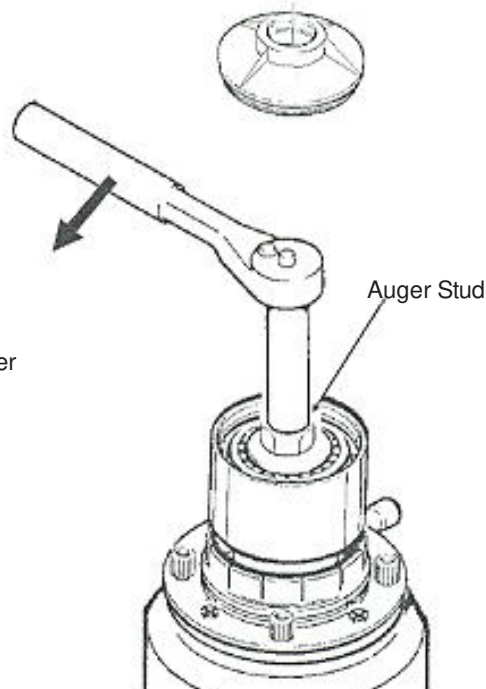
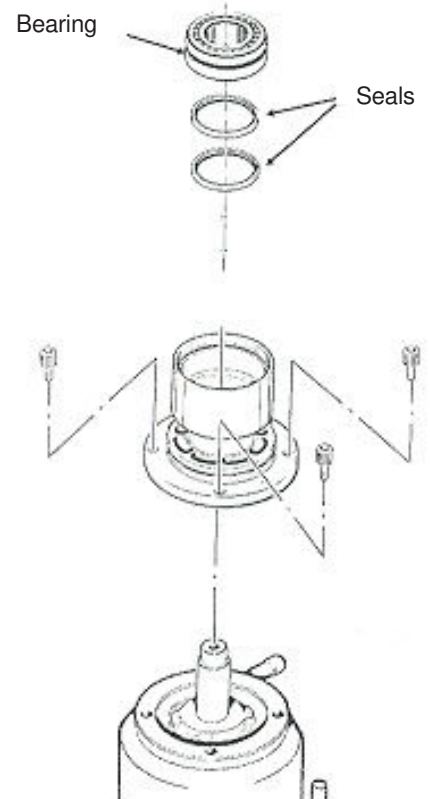

Fig. 3



To Remove the Auger:

1. Disconnect electrical power.
2. Turn off the water to the machine.
3. Unclip the evaporator drain hose, pull it down and drain the evaporator into the bin or container.
4. Remove the top panel.
5. Swing bail clip down and remove the ice chute cover.
6. Unscrew ice sweep.
7. Remove ice chute body.
8. The auger and breaker/bearing may now be removed as an assembly.
 - a. Unscrew four (4) Allen head cap screws holding breaker to evaporator.
 - b. Lift up on breaker and remove auger from evaporator.

Note: If the auger is stuck, the breaker must be removed from the auger.

9. The breaker may be removed from the auger and evaporator without disturbing the auger.
 - a. Unscrew breaker cover from the breaker. **(Note: Left hand Threads)**
 - b. Unscrew auger stud from top of auger.
 - c. Unscrew four (4) Allen head cap screws holding breaker to evaporator.
 - d. Lift up and remove breaker from evaporator.
 - e. If the auger is stuck, use a slide hammer type of puller to pull on the auger at the threaded hole. The size of that hole is 5/8"-18.
10. Inspect the auger, the critical areas of the auger are:
 - a. The auger body. It should be clean and shining. Sometimes an auger will appear clean when wet, but after it is dry it will be seen to be stained. Scrub the auger with ice machine cleaner and hot water.
 - b. The water seal area. Because the auger has been removed, the water seal will have to be replaced. Remove the water seal top half from the auger, and inspect the auger for minerals, clean as required.



Breaker and Auger Assembly

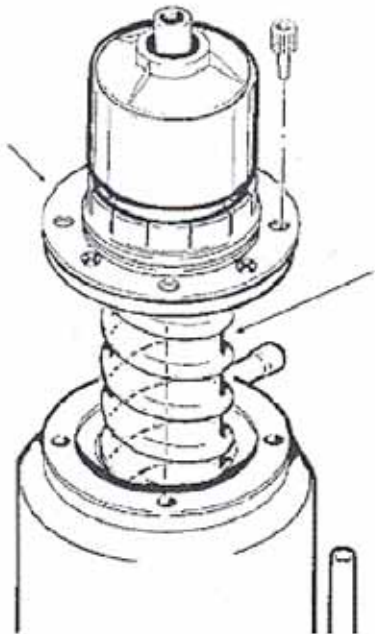

WARNING!
The auger has sharp edges, handle with care.

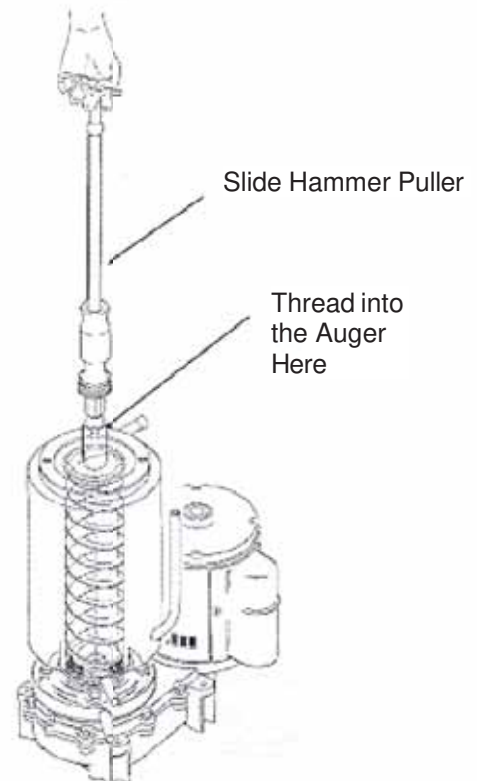

To Remove the Water Seal:

- (Assuming all steps to remove the auger have been performed)
1. The gear motor/evaporator assembly will have to be exposed.
 2. Remove the four (4) hex head cap screws holding the evaporator to the gear motor assembly. Lift the evaporator up and off the gear motor.
 3. Remove the snap ring or wire retainer from the groove under the water seal.
 4. Pull or drive out the lower half of the water seal.

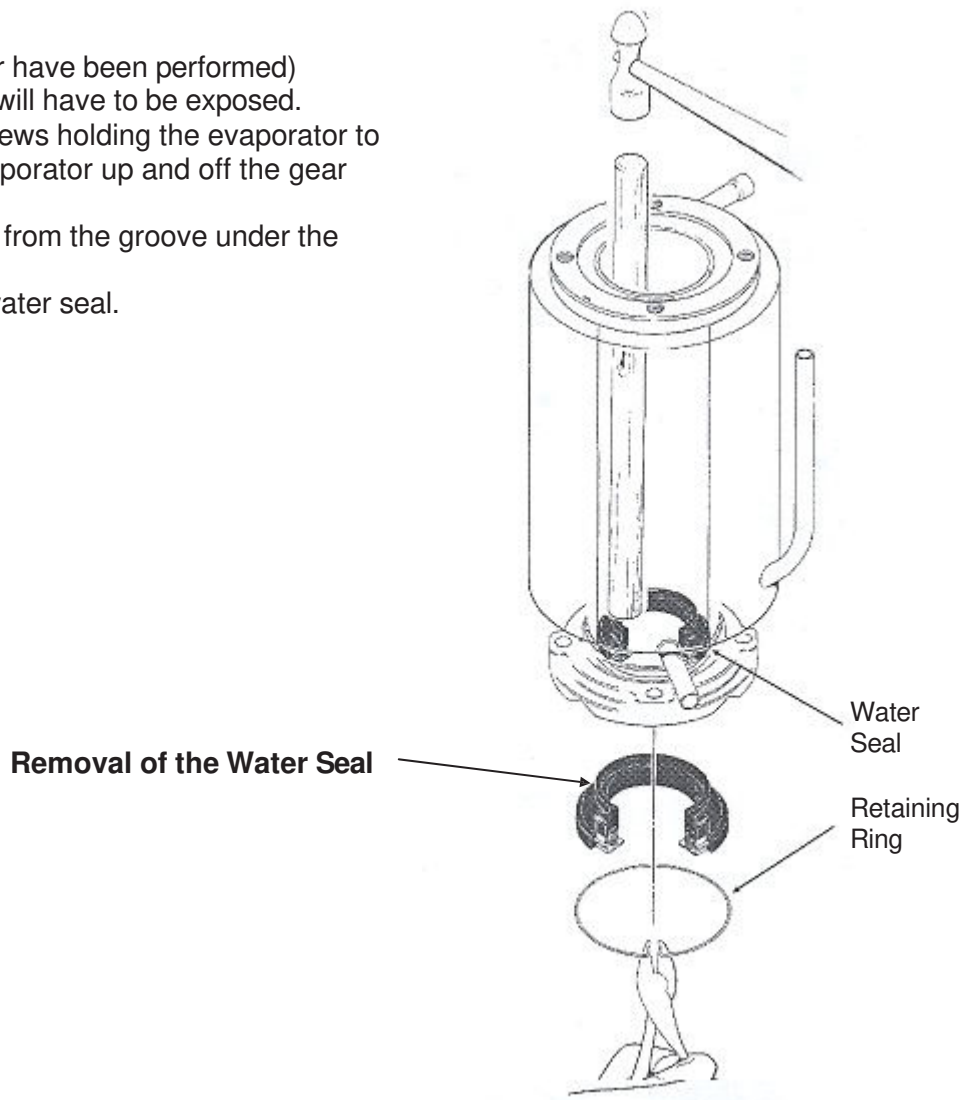

To Replace the Water Seal:

1. Lubricate the water seal with water, and push the water seal into the bottom of the evaporator slightly past the groove for the snap ring.
2. Replace the snap ring and pull the water seal down against it.
3. The part of the water seal that rotates with the auger must also be replaced. Remove the old part from the auger and clean the mounting area.
4. Place a small bead of food grade silastic sealant (Such as 732 RTV) on the area of the auger where the water seal is to be mounted.
5. Carefully push the water seal (Rubber side against the auger shoulder and the silastic.)
6. Allow the auger and seal to air dry until the silastic is dry on the surface.
7. If the original water seal was leaking, it would be a good idea to inspect the interior of the gear motor.

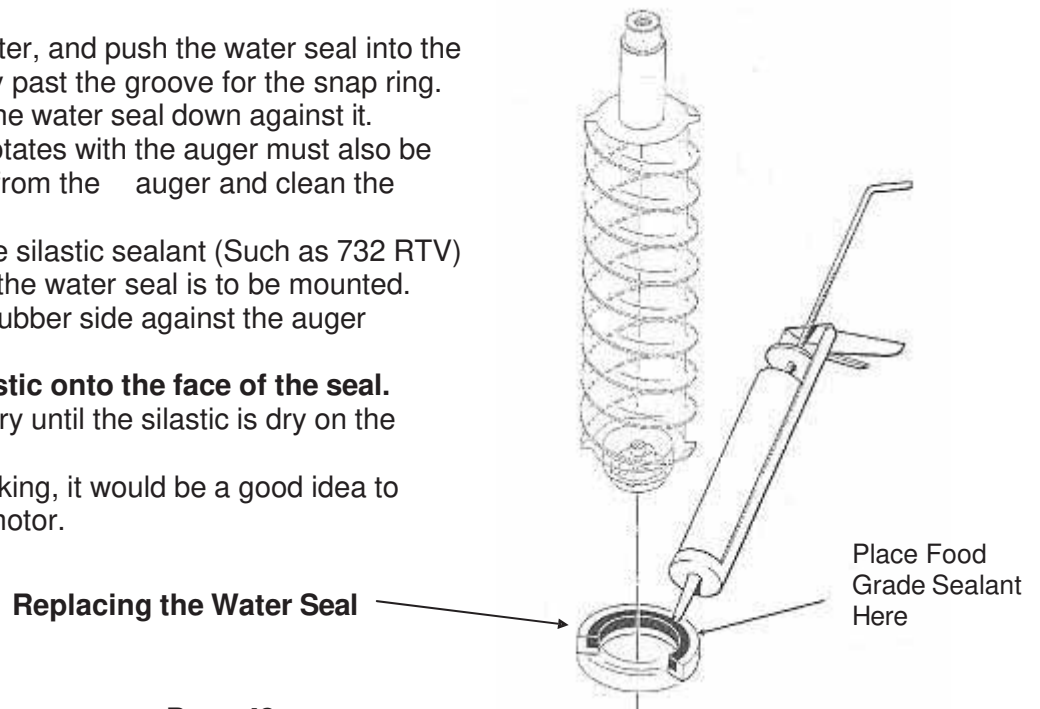

To Replace the Evaporator:

(Assuming all steps for removal of the thrust bearing, breaker, auger and water seal have been performed).

1. Recover the refrigerant from the ice machine.
2. Unsweat the refrigerant connections:
 - a. At the thermostatic expansion valve outlet.
 - b. At the suction line at the joint about three (3) inches from the evaporator.
3. Remove the evaporator.
4. Unsweat the drier from the liquid line.
5. After installing a new water seal in the new evaporator (see "to Replace the Water Seal") sweat in the new evaporator at the old tubing connections.
6. Install a new drier in the liquid line.
7. Evacuate the system until dehydrated, then weigh in the nameplate charge. Check for leaks.
8. Install auger, breaker, breaker bearing assembly and ice discharge chute in reverse order of disassembly.

To Reassemble the Evaporator and Auger:

1. After the gear motor has been inspected, fasten the evaporator to the gear motor. Torque the bolts to 110 **inch** pounds
2. Lower the auger into the evaporator barrel, slightly turning it to match up with the drive end. **Do Not Drop** the auger into the evaporator.
3. Complete the reassembly by reversing the disassembly for the breaker and thrust bearing.

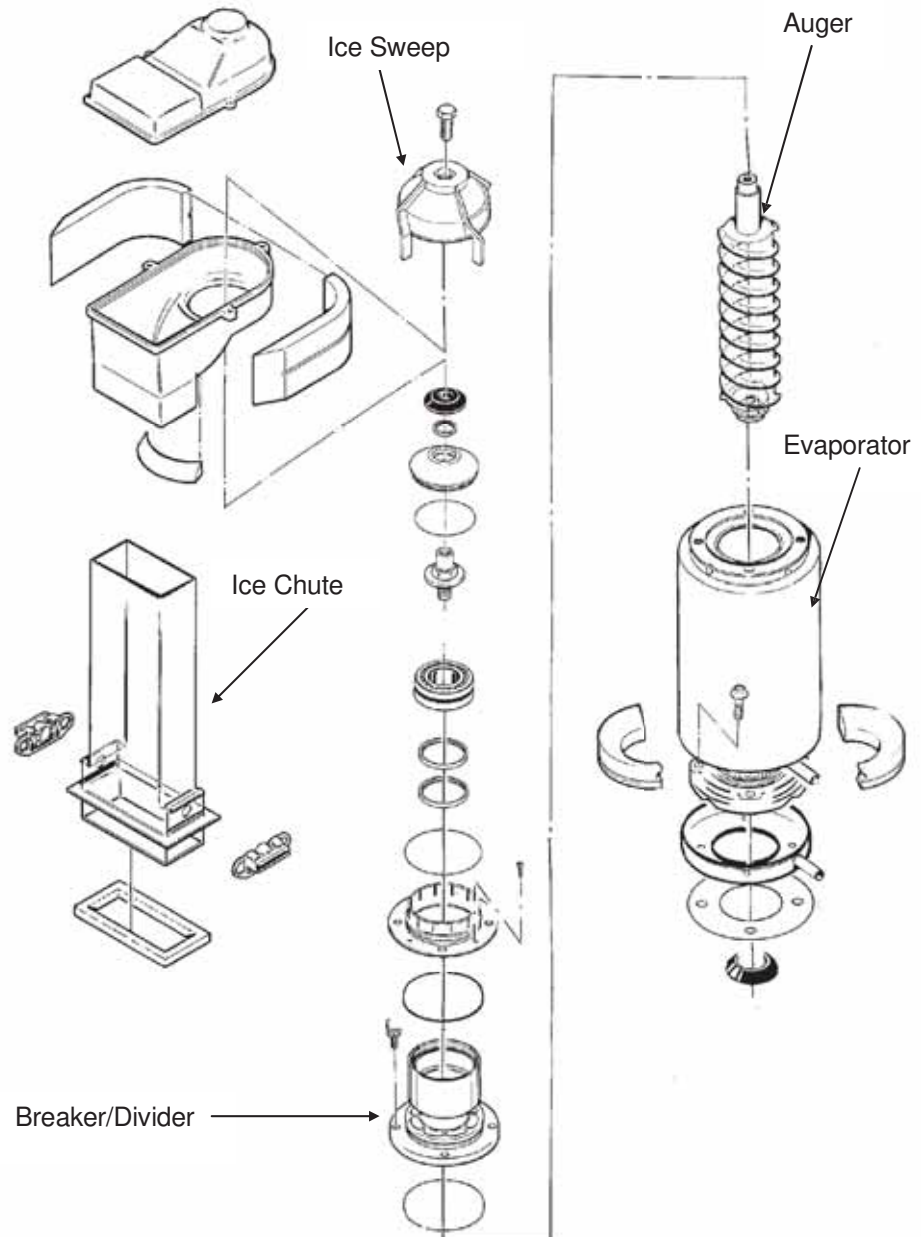

Caution: Heat sink the TXV body when unsweating or resweating the adjacent tubing.

To Check the Gear Motor:

1. Remove wires from terminals 1 and 2
2. Use an ohmmeter to check for continuity. If there is none, replace only the motor. If there is continuity but the motor will not start, check the motor's start switch.
3. Remove motor end bell or motor stator. With ohmmeter wires attached to 1 and 2 move centrifugal switch actuator up and down to simulate motor rotation. If the ohmmeter does not show any change, replace the switch or motor. If the ohmmeter shows an open circuit, replace the switch or motor.



To Remove and Repair the Gear Motor Assembly:

(Assuming that the procedures through removal of the water seal have been performed)

1. Remove the electrical wires from the gear drive motor.
2. Unscrew the four (4) cap screws holding the gear motor to the base of the machine. remove the gear motor from the machine.

Note: Bench test the gear motor, check for oil leaks, noise and amp draw.

To Inspect the Gear Case Assembly:

1. The oil charge is 14 ounces. Do not overfill.
2. There are no serviceable parts in the gearcase assembly. If the gears or bearings are damaged the entire gearcase assembly will require replacement.

Cover and Output Gear Assembly

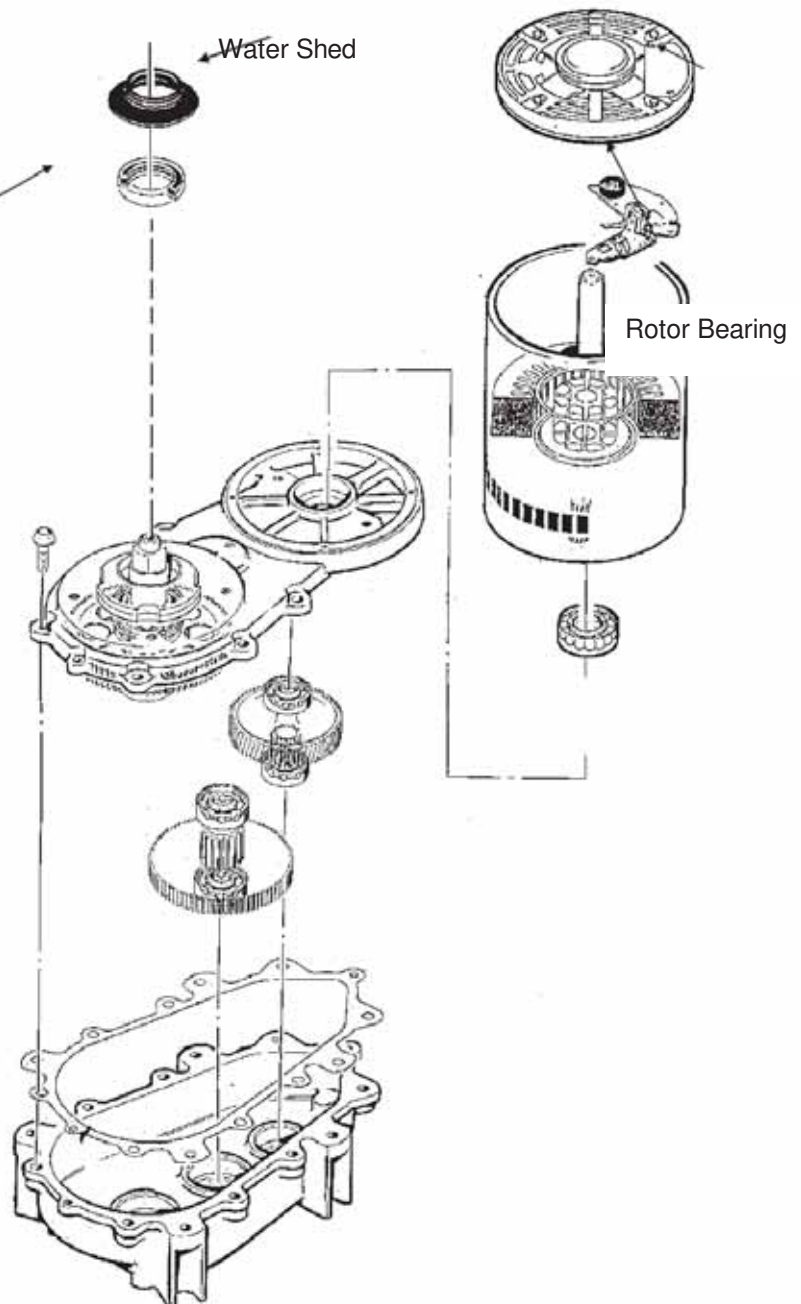

To Remove the Condenser Fan Motor Assembly: (GEM0956 Air Shown)

1. Disconnect electrical power to the ice machine
2. Remove top panel and the service panels.
3. Unplug the fan motor wire leads from the fan motors.
4. Remove the two (2) head bolt from the top end of the fan motor assembly. (Fig 1)
5. Lift up the fan motors and bracket assembly about ½ inch and pull out the fan assembly out the right service access hole. (Fig 2)
6. Repair as needed.
7. To Reassemble: Place the fan motor assembly lower flange holes over the two Allen head cap screws in the base, and install the hex head bolts at the top of the assembly. Plug the fan motors back in and replace the panels.



Fig.1

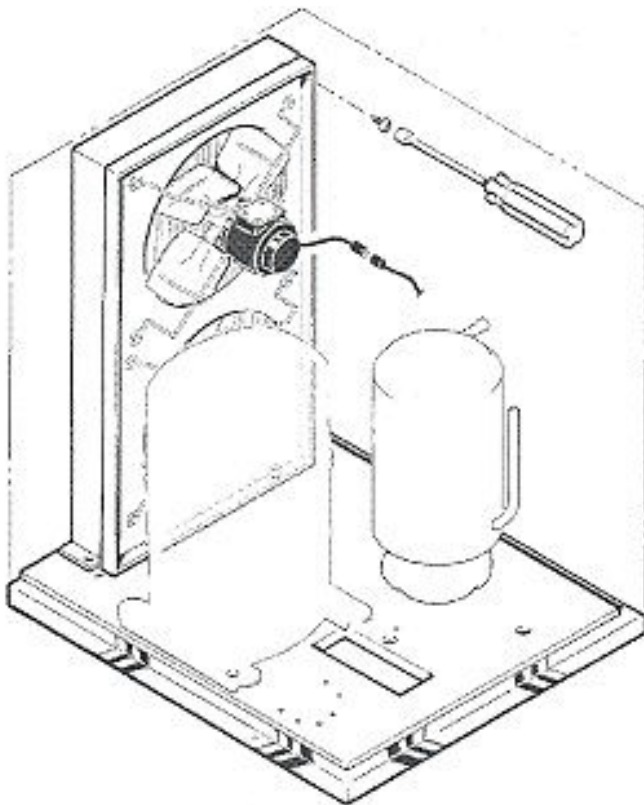
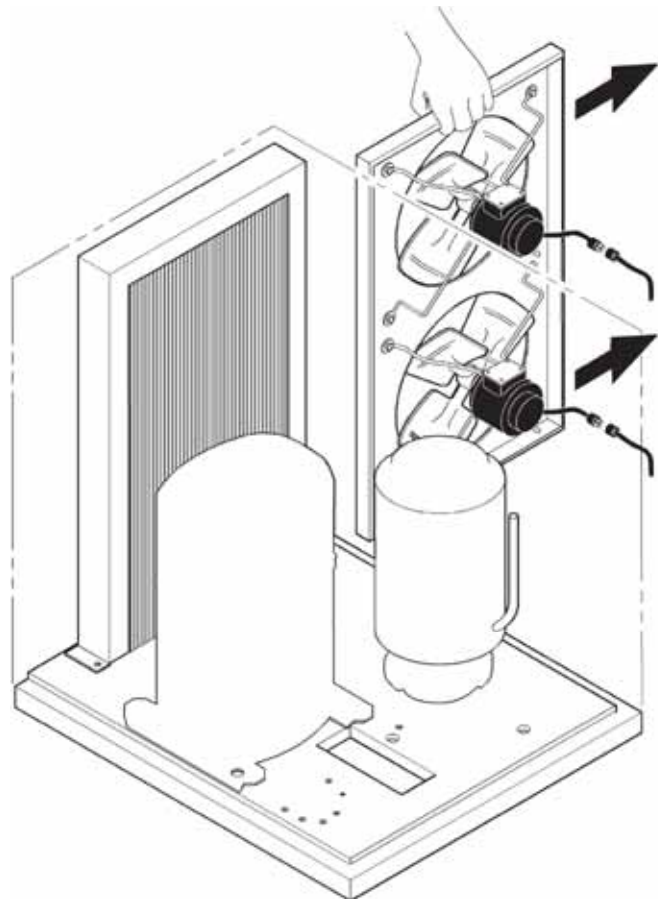
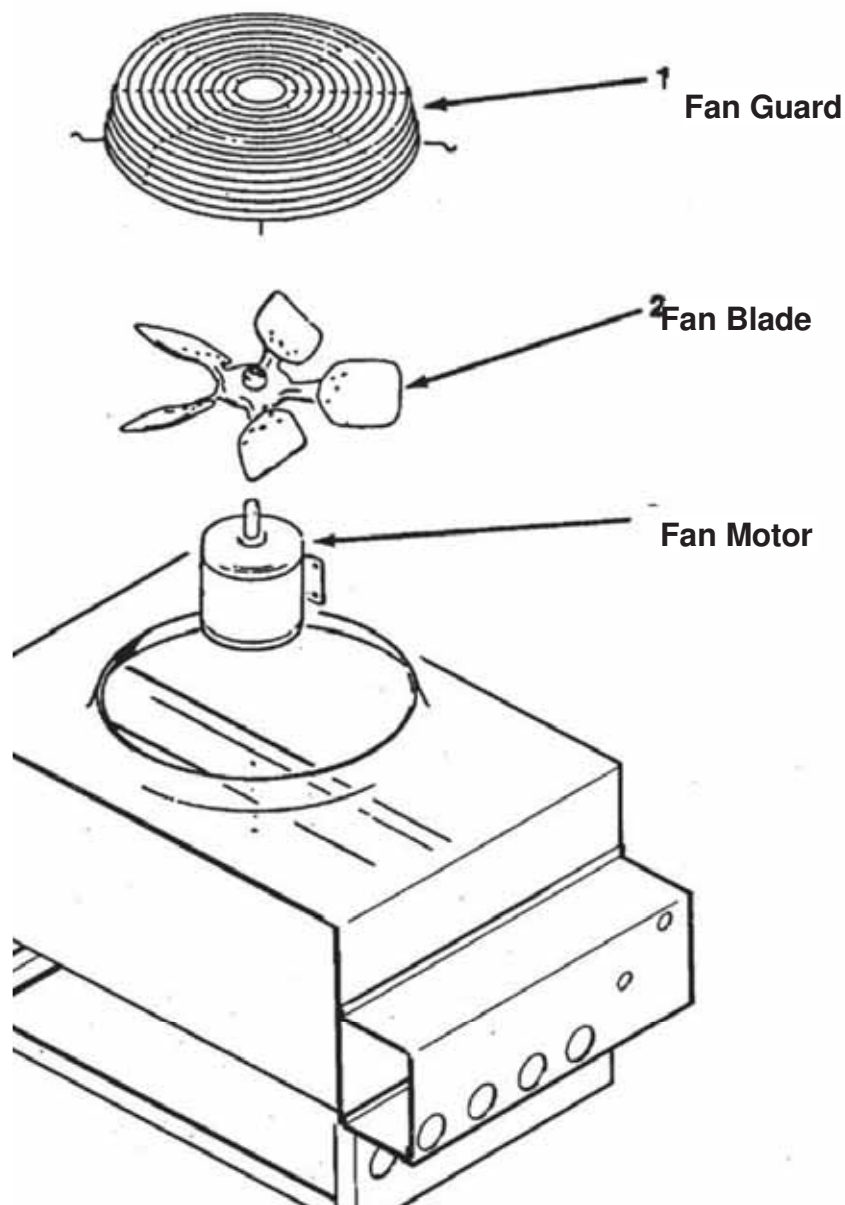

Fig. 2



To Remove the Remote Condenser Fan Motor Assembly:

1. Disconnect electrical power to the ice machine and/or remote condenser.
2. Remove fan guard.
3. Remove the fan blade.
4. Disconnect the electrical power lead to the fan motor.
5. Remove the four (4) bolts from the fan motor assembly.
6. Remove the fan motor assembly.
7. To Reassemble: Place the fan motor assembly on the condenser bracket and install the bolts. Wire the fan motor power leads, install the fan blade and replace the fan guard.



Refrigeration Service: Air and Water Cooled

General: This ice machine uses R404A refrigerant and polyolester oil. Do NOT use mineral oil in this refrigeration system.

- When the refrigeration system is serviced, a special liquid line drier is required. It is included with replacement compressor.
- R404A is not compatible with mineral oil so these ice machines use Polyolester oil. Polyolester oil absorbs water very easily. A system opened for service must be re-sealed as soon as possible (15 minutes maximum).
- Special leak detection equipment is required to locate small refrigerant leaks. Usually a leak detector capable of detecting Halogenated refrigerant or HFC-134a will work. Check with the leak detector manufacturer if in doubt.
- Evacuate to 300 microns.
- Liquid charge the system.

R-290 Troubleshooting

R-290 is an A3 refrigerant, which refers to refrigerant grade propane (pure), a substance that is odorless, highly flammable and displaces air as it is heavier than air. This refrigerant has been used in the industry for several years. Specific precautions should be taken when handling R-290. Since R-290 is flammable, work in an open, well-ventilated area.

Use appropriate tools to ensure safety.

- Combustible gas leak detector
- Tubing cutters
- Pinch-off tool
- Voltmeter
- Amp meter
- Temperature clamp probes
- Schrader taps
- Combustible gas Warning signs
- Refrigerant scale
- Vacuum pump
- Nitrogen
- R290 Temperature pressure Chart



All of the components work the same. But testing of the refrigeration section will be a little different. Pressure will not be tested until the last resort as these units are critically charged.

Using a temperature pressure chart you can determine approx. pressure.

Measuring compressor amperage can show workload of the compressor to determine if the charge is correct, restriction, or compressor performance. High amperage could be indicative of dirty condenser coils, condenser fan motor, compressor beginning to fail, or low voltage to the compressor.

Low amperage could be a compressor motor weak or failing, low refrigerant charge, restriction, or the valves in compressor not pumping

Using temperature clamps txv operation, hot gas valve operation, evaporator performance, and condenser performance can be determined.

Units are sealed no Schrader ports and will need to be resealed after refrigeration service.

Instructions for Liquid Charging R404A and R449:

In preparation for charging, the low side hose should have a sight glass, and/or a restricting device (such as a “Charge Faster”) installed in it for metering liquid into the low side of the system.

1. After a through evacuation shut off the manifold valves and switch off the vacuum pump.
2. Place a drum of R404A onto an electronic scale.
3. Attach the charging hose to the drum.
4. Open the valve on the drum and purge the charging hose.
5. Zero out the scale.
6. Shut the low side access valve at the ice machine.
7. Open the discharge manifold valve full open.
8. Watch the scale, when the correct charge is shown, shut the manifold valve.

Note: If all of the charge will not “go in” the discharge side:

- a. Shut the discharge access valve at the ice machine.
 - b. Switch the machine on.
 - c. Open the low side access valve at the ice machine.
 - d. Open the low side manifold valve and observe the sight glass to be certain that only gas is flowing into the system.
 - e. When the proper charge is indicated on the scale, shut off the manifold valves.
9. Shut off the valve on the refrigerant drum.
 10. Re-open the manifold valves until all liquid has flowed out of the hoses.
 11. Shut the low side access valve on the ice machine.
 12. Remove hoses from ice machine and replace all caps.

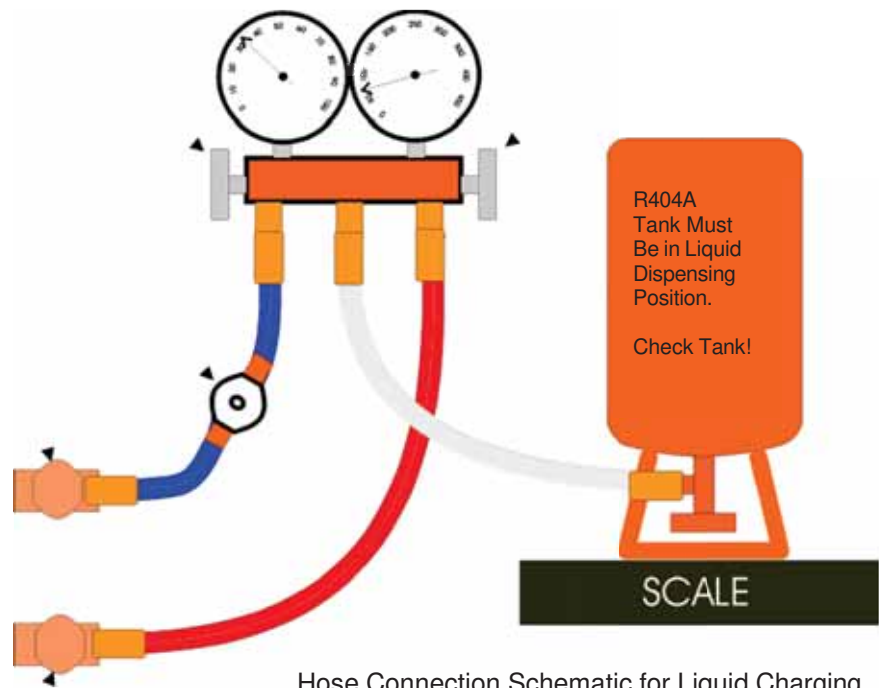

Hose Connection Schematic for Liquid Charging

GEM-MFI SERIES**R290 Charging procedure.**

1. Prepare for Safety
 - b. Ventilation and Safety: Work in a well-Ventilated area, as R290 is highly Flammable.
 - c. Safety Gear: Wear appropriate PPE.
 - d. Gas Detector: Use a combustible gas leak detector the entire time you are working on the unit.
 - e. Power Off: Make sure power is disconnected before you begin.
2. Connect the Equipment
 - a. Attach piercing valves to the systems process ports.
 - b. Attach manifold to Cylinder and set on scale.
 - c. Bleed the air out of hoses and pre-charge hoses.
 - d. Zero out the scales.
3. Charge the System
 - a. Open the appropriate hose on scale and weigh in the exact charge slowly.
 - b. Close manifold.
 - c. Pinch off Process port on system side of line tap side of valve using a pinch off tool.
 - d. Safely disconnect the R290 cylinder and disconnect the charging hose, purging any remaining refrigerant in the hose.
4. Seal the system.
 - a. Using leak detector make sure pinch off is secure no leaks.
 - b. Pinch again 1/ 4" before creating a double pinch. Cut access port off and recheck for leak.
 - c. Solder process tube to seal.

Refrigeration Service: Remote

General: This ice machine uses R404A or R449A refrigerant and polyolester oil. Do NOT use mineral oil in this refrigeration system.

Please Note: Due to Environmental regulations, we are moving away from R-404A refrigerant, and it is being replaced by R-449A refrigerant. These 2 refrigerants are very similar in pressures and only require an Expansion valve change. All other refrigeration practices are still going to be in use.

- When the refrigeration system is serviced, a special liquid line drier is required. It is included with replacement compressors.
- R404A and R449A is not compatible with mineral oil so these ice machines use Polyolester oil. Polyolester oil absorbs water very easily. A system opened for service must be re-sealed as soon as possible (15 minutes maximum).
- Special leak detection equipment is required to locate small refrigerant leaks. Usually a leak detector capable of detecting Halogenated refrigerant or HFC-134a will work. Check with the leak detector manufacturer if in doubt.
- Evacuate to 300 microns.
- Liquid charge the system.

Access Valves: To use the access valves:

- Remove the cap from the stem, use a 3/16 inch Allen wrench to check that the valve is CLOSED. Then remove the core cap.
- Close the valve and replace the caps when done. The valve must be closed and the caps tightened.

Torque Stem to 6-8 ft.-lb.
Torque Caps to 7-12 ft.-lbs

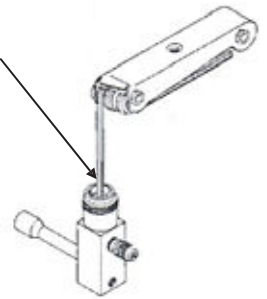

Charging Procedure

- Extra care must be taken when charging this remote system. No liquid refrigerant may be placed in the system at the compressor. DO NOT use the access valves at the front of the unit for weighing in the charge.

All liquid refrigerant must be weighed into the receiver through the front seated "king valve".

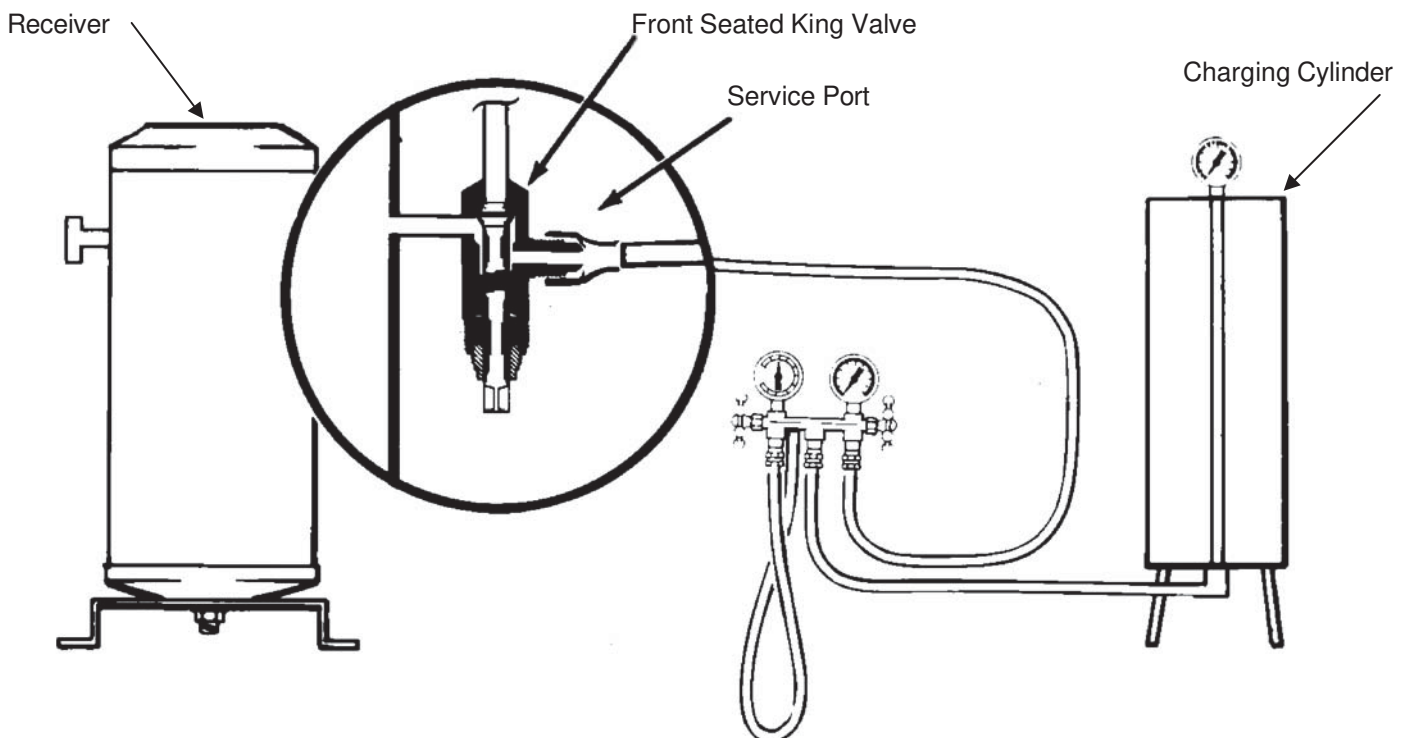

R-290 Troubleshooting

R-290 is an A3 refrigerant, which refers to refrigerant grade propane (pure), a substance that is odorless, highly flammable and displaces air as it is heavier than air. This refrigerant has been used in the industry for several years. Specific precautions should be taken when handling R-290. Since R-290 is flammable, work in an open, well-ventilated area.

Use appropriate tools to ensure safety.

- Combustible gas leak detector
- Tubing cutters
- Pinch-off tool
- Voltmeter
- Amp meter
- Temperature clamp probes
- Schrader taps
- Combustible gas Warning signs
- Refrigerant scale
- Vacuum pump
- Nitrogen
- R290 Temperature pressure Chart



All of the components work the same. But testing of the refrigeration section will be a little different. Pressure will not be tested until the last resort as these units are critically charged.

Using a temperature pressure chart you can determine approx. pressure.

Measuring compressor amperage can show workload of the compressor to determine if the charge is correct, restriction, or compressor performance. High amperage could be indicative of dirty condenser coils, condenser fan motor, compressor beginning to fail, or low voltage to the compressor.

Low amperage could be a compressor motor weak or failing, low refrigerant charge, restriction, or the valves in compressor not pumping

Using temperature clamps txv operation, hot gas valve operation, evaporator performance, and condenser performance can be determined.

Units are sealed no Schrader ports and will need to be resealed after and refrigeration service

Wiring Diagram GEM0450A/W, MFI0500A/W

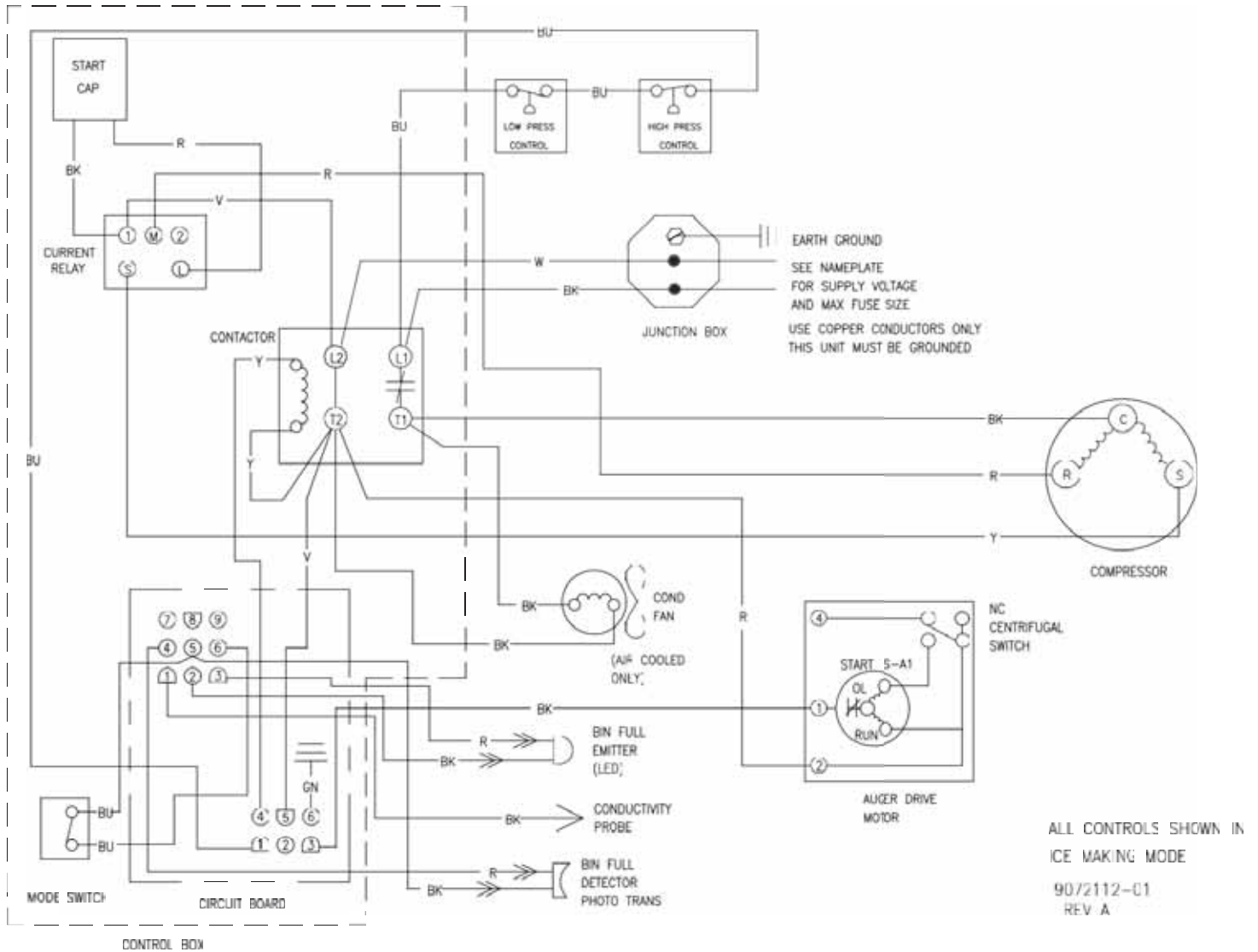

Ladder Diagram GEM0450A/W, MFI0500A/W

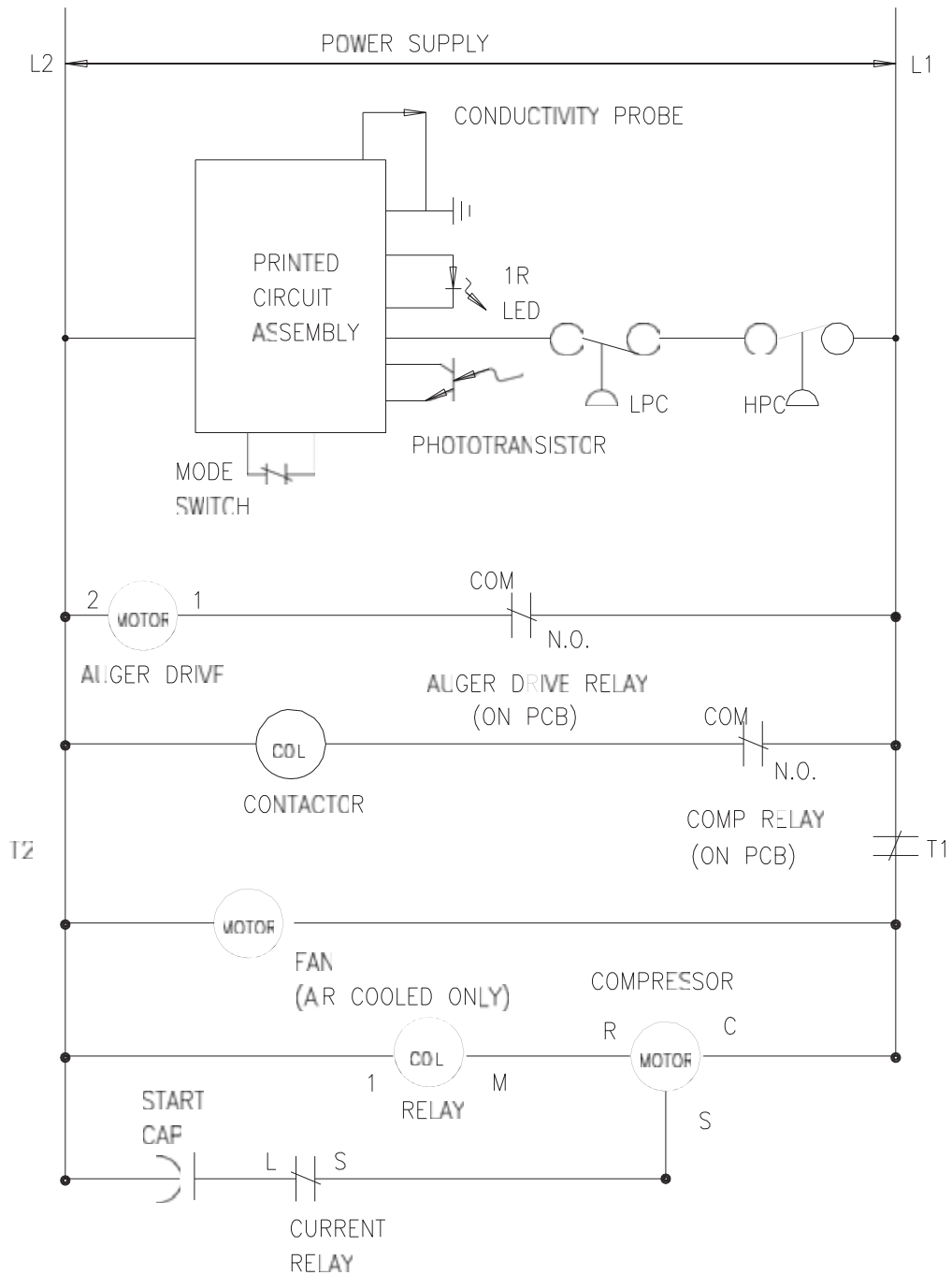

ALL CONTROLS SHOWN IN
ICE MAKING MODE

9072112-01
REV A

Wiring Diagram GEM0650A/W, MFI0800A/W

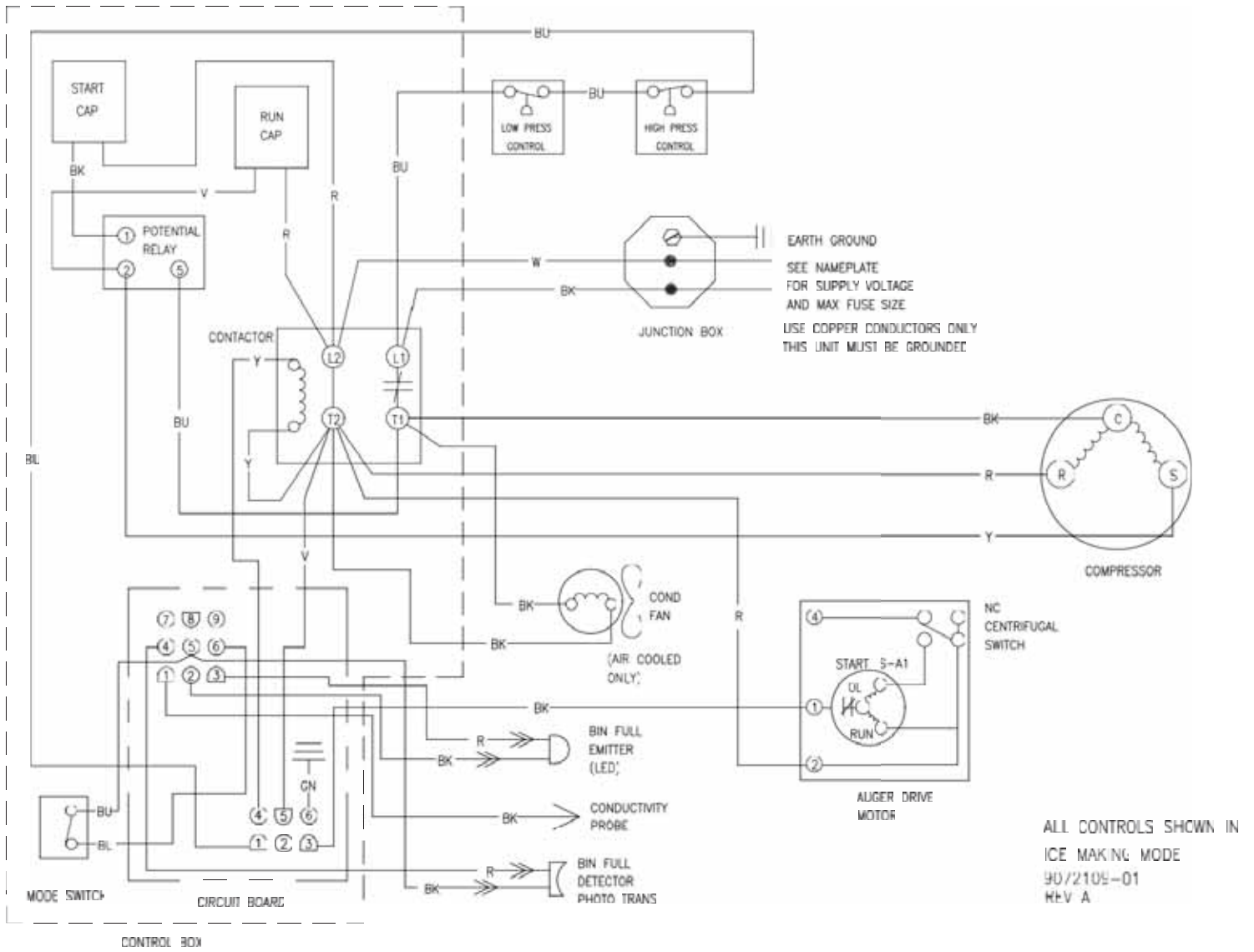

Ladder Diagram GEM0650A/W, MFI0800A/W

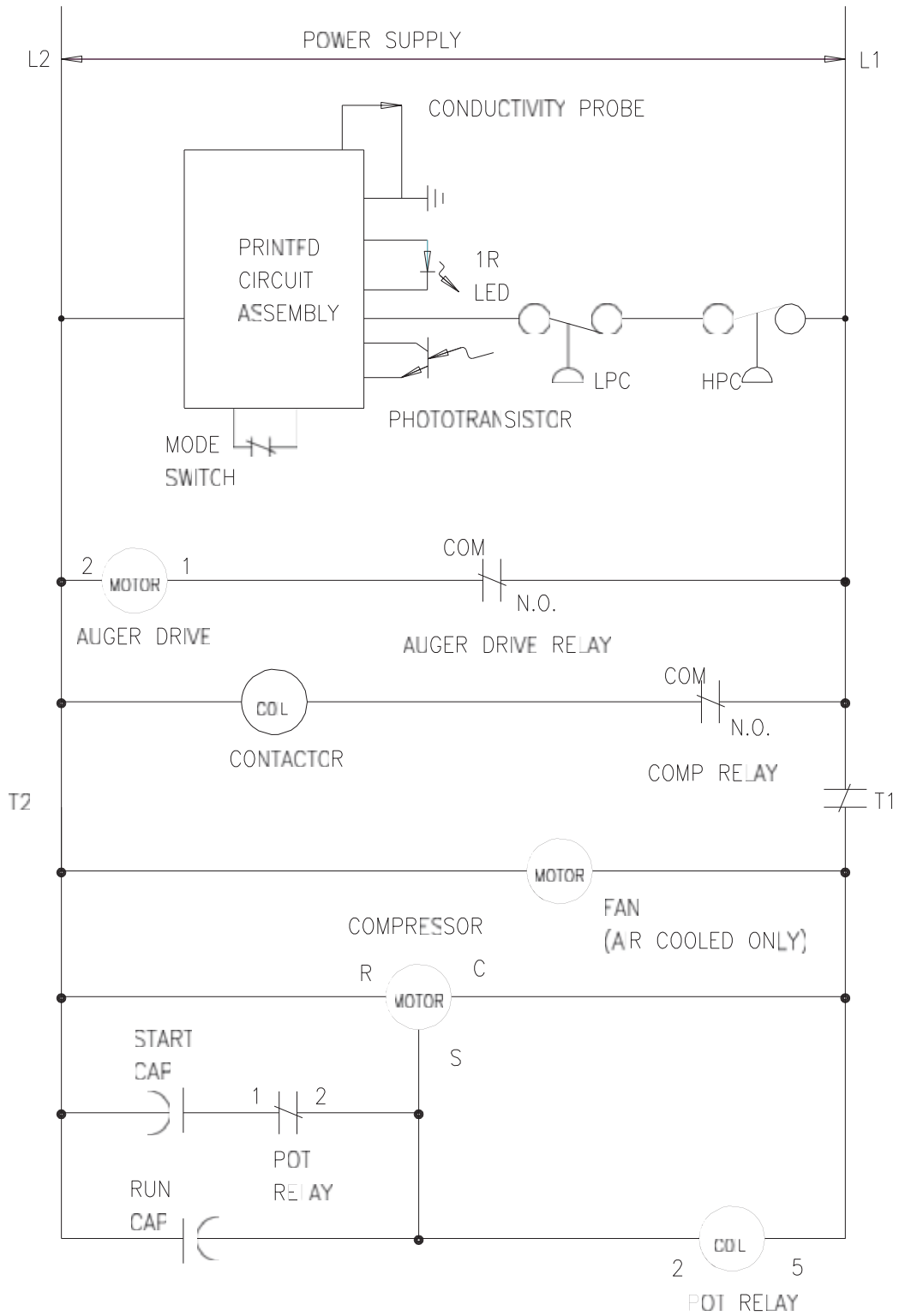

ALL CONTROLS SHOWN IN
ICE MAKING MODE

9C721C9-C1
REV A

**Wiring Diagram GEM0655A/W, MFI0805A/W
GEM0955A/W, MFI1255A/W**

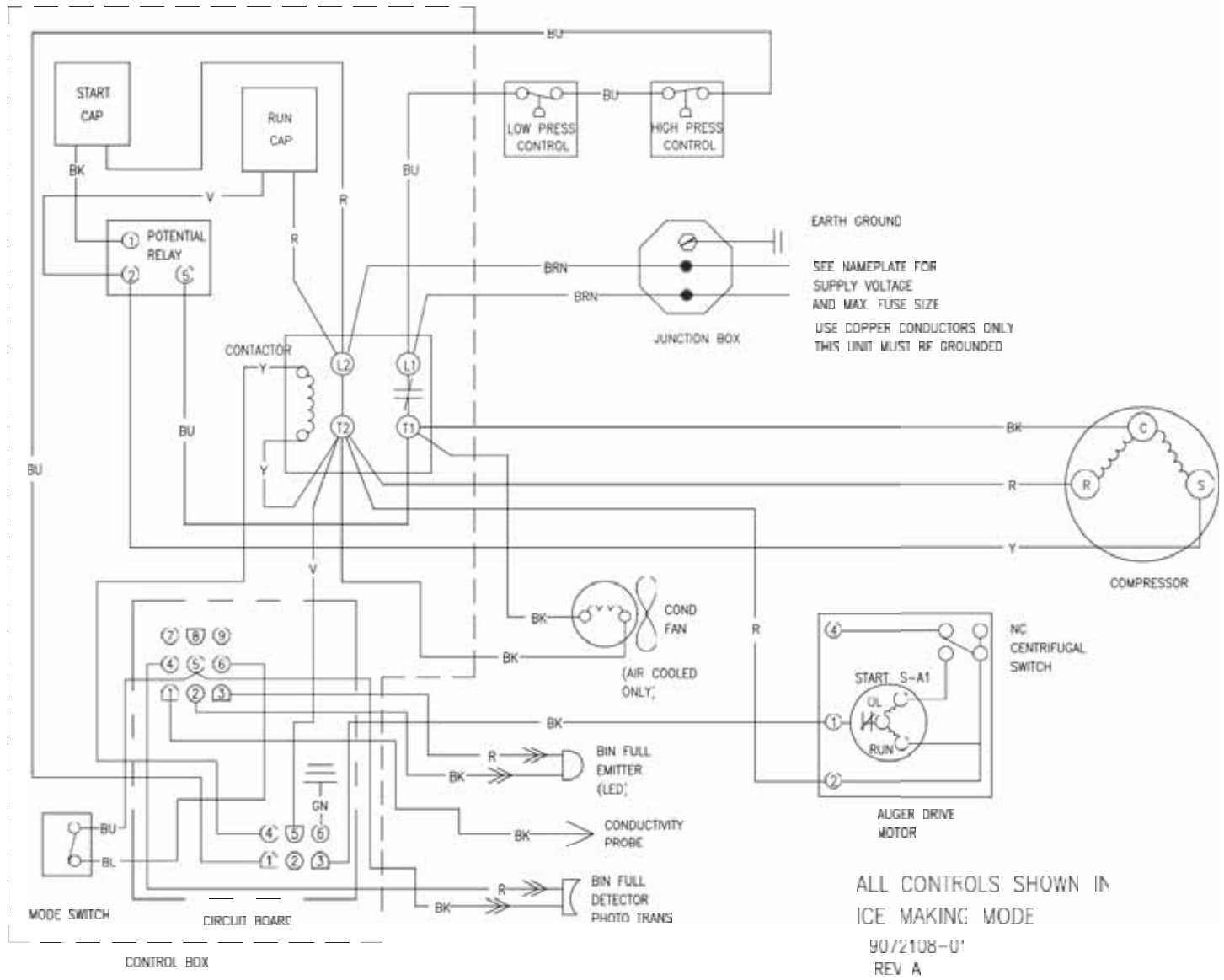

Ladder Diagram GEM0650R, MFI0800R

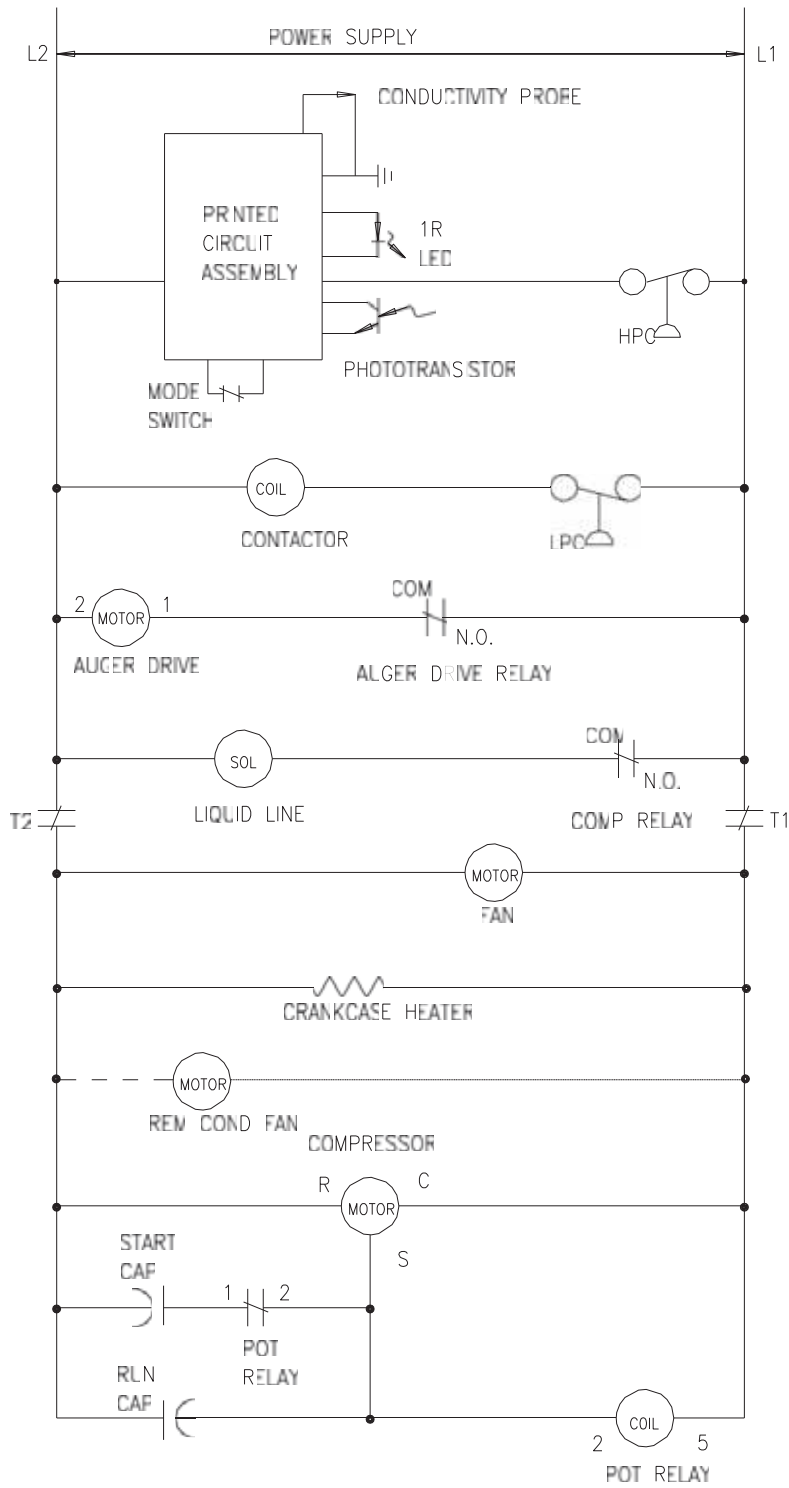

ALL CONTROLS SHOWN IN
ICE MAKING MODE

9072110-01
REV A

Wiring Diagram GEM0956A/W, MFI1256A/W, GEM1306A, MFI1506A

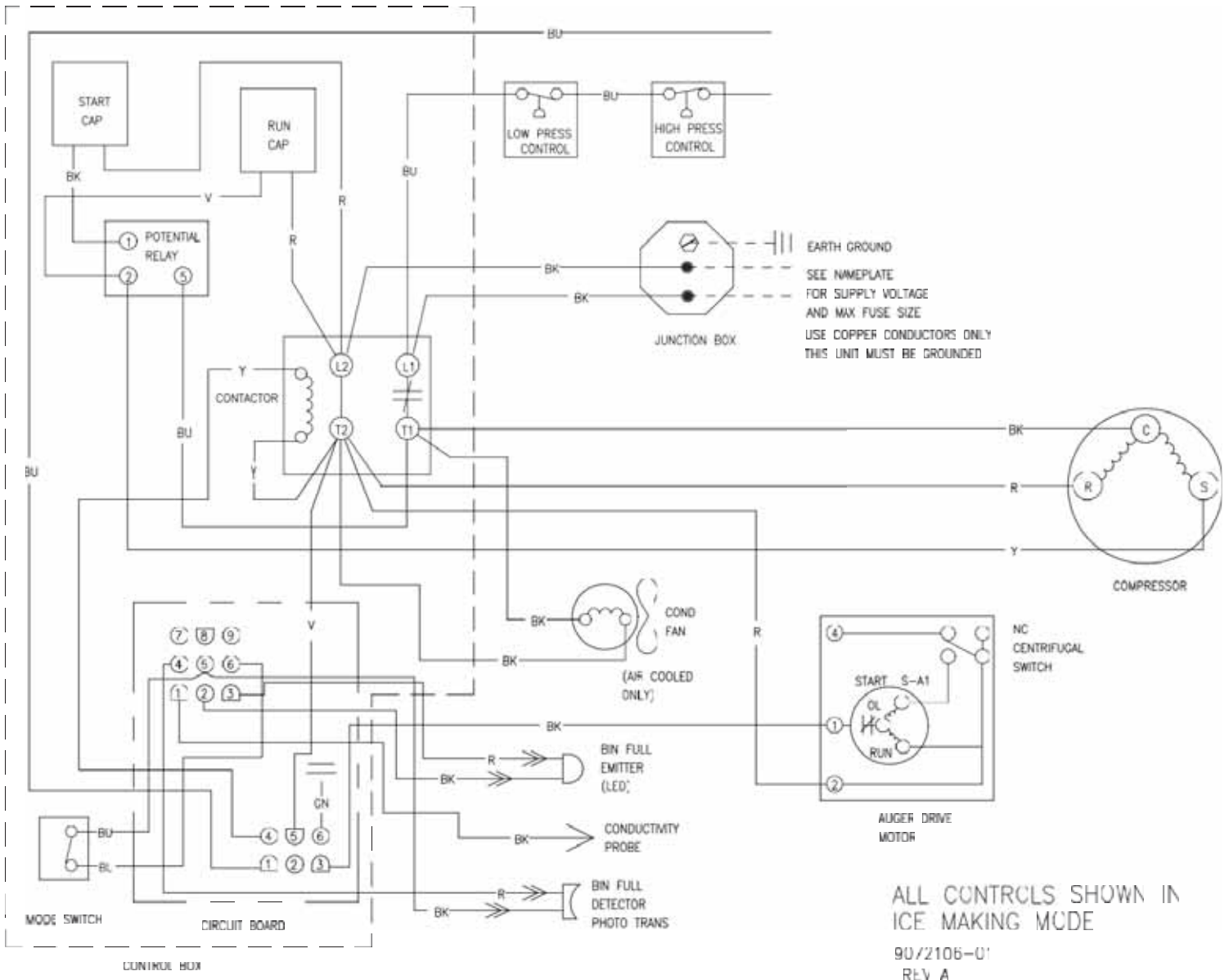

Ladder Diagram GEM0956A/W, MFI1256A/W, GEM1306A, MFI1506A

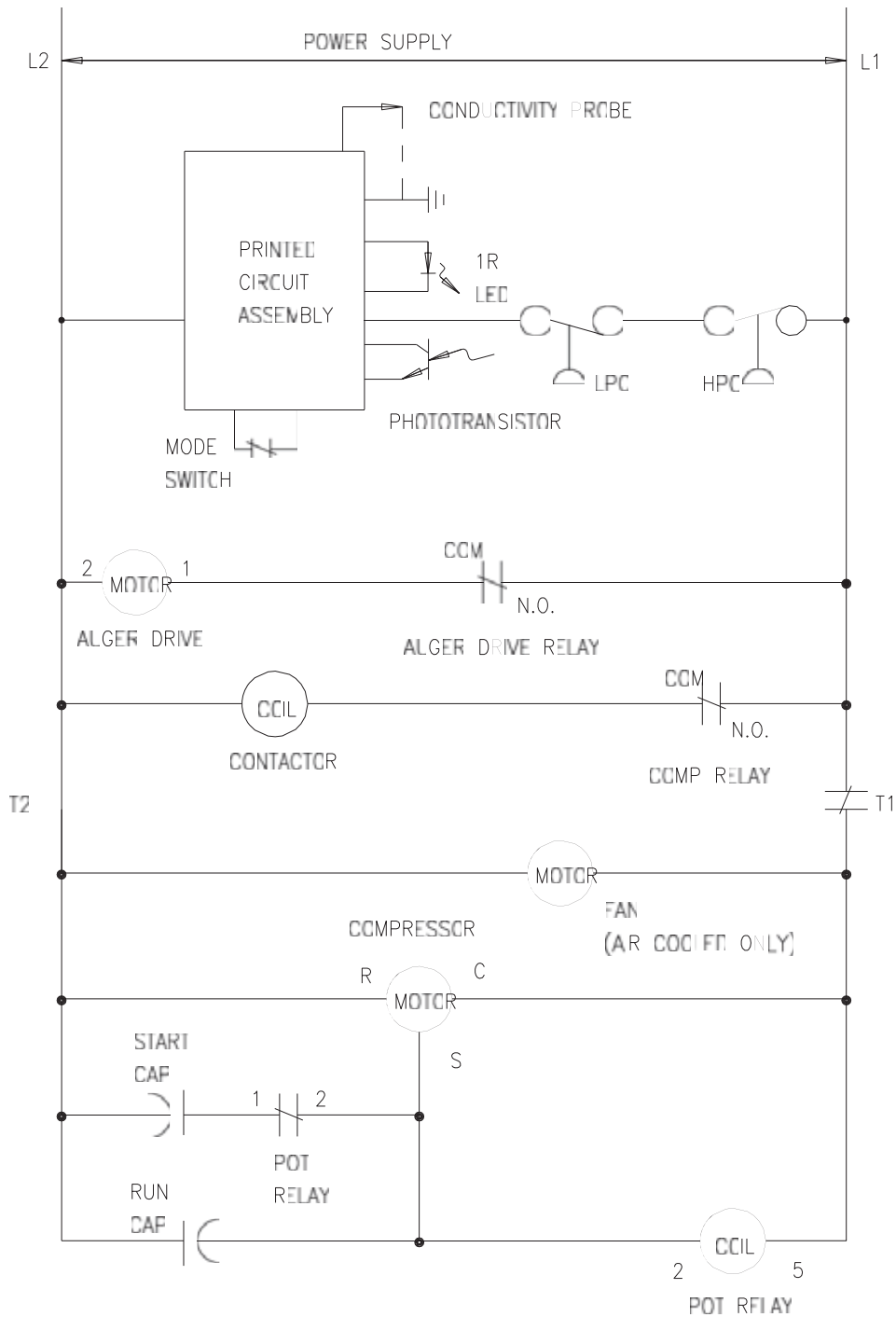

ALL CONTROLS SHOWN IN
ICE MAKING MODE

9072106-01
REV A

Wiring Diagram GEM0956R, MFI1256R

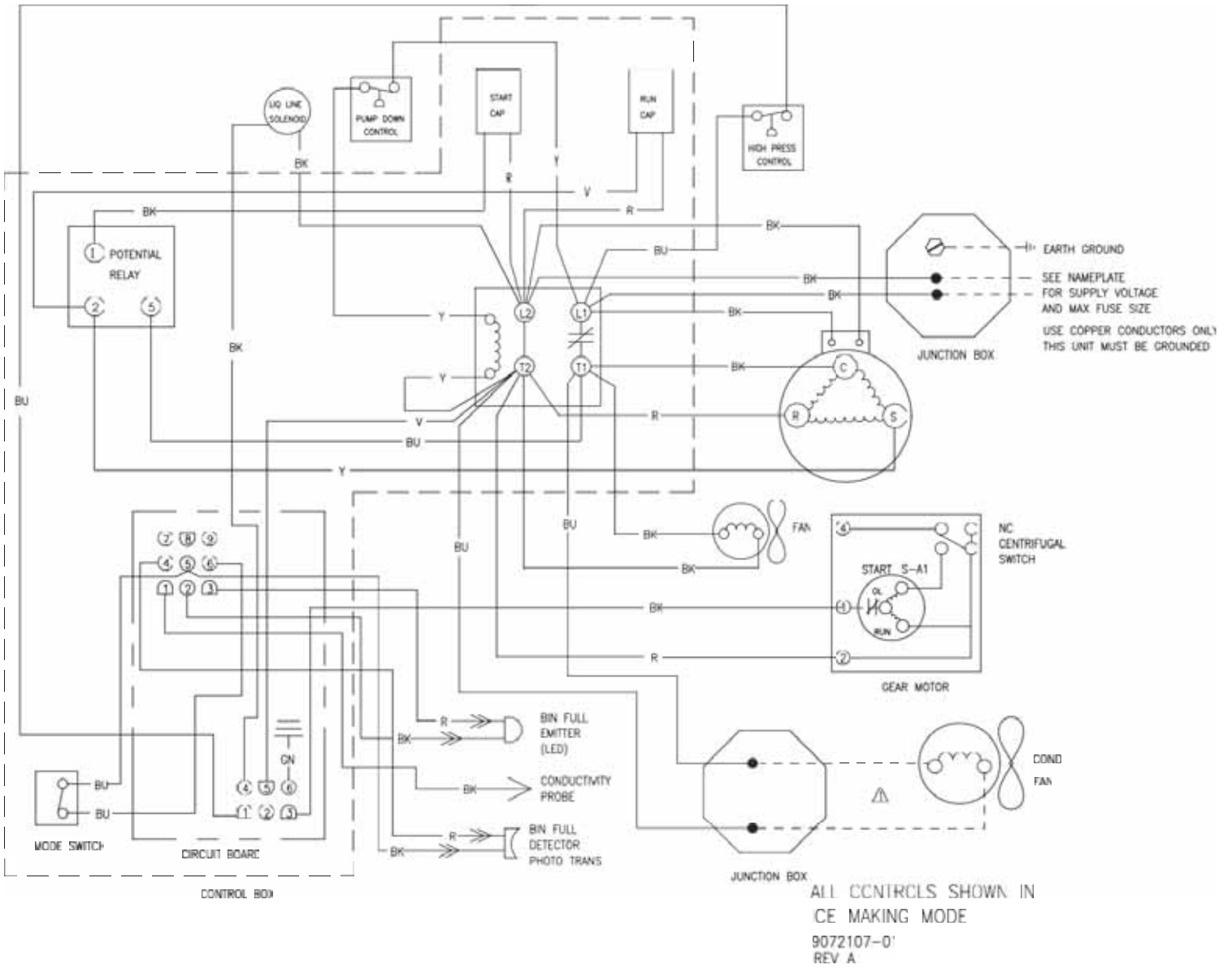

Ladder Diagram GEM0956R, MFI1256R

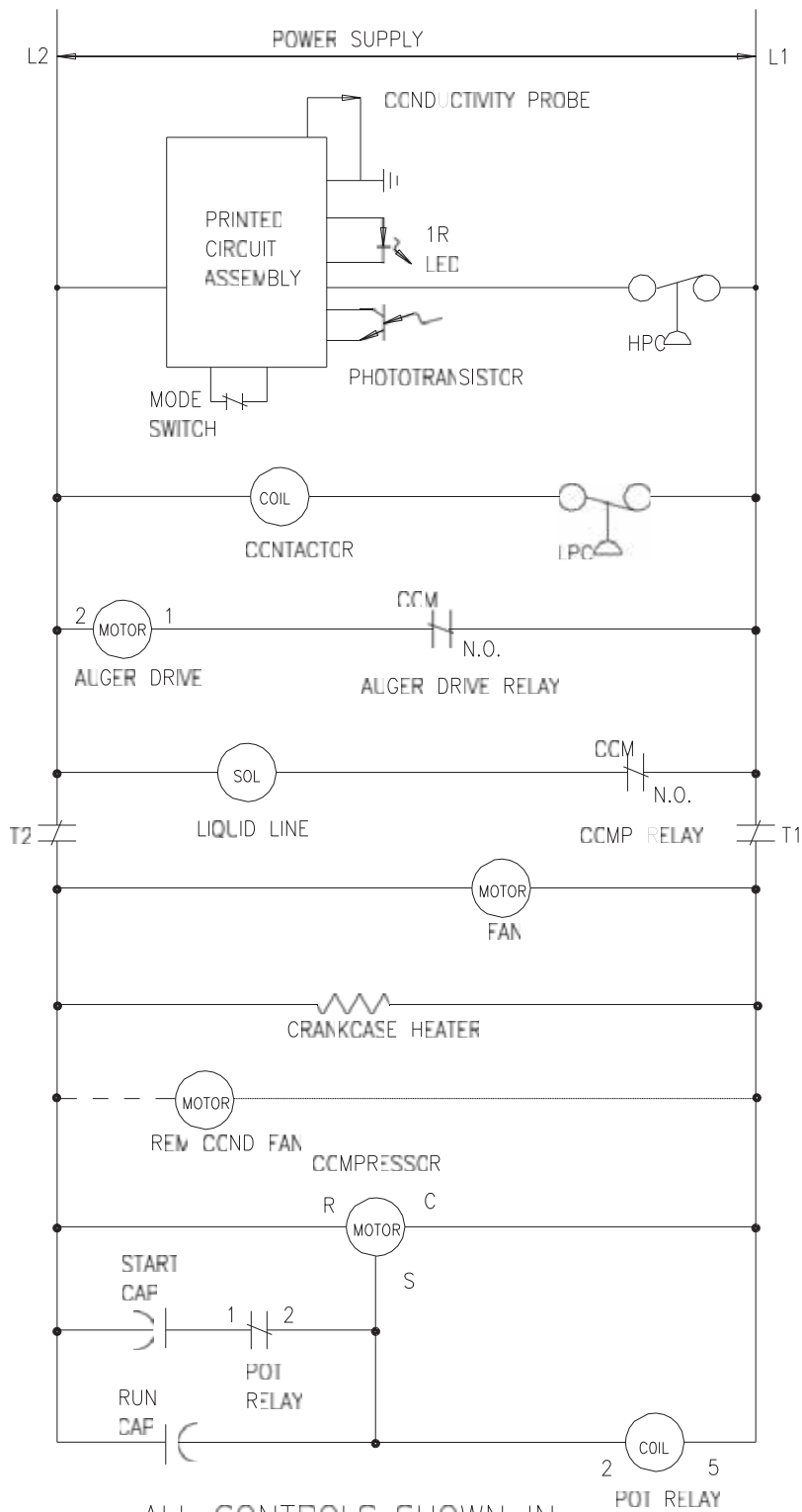

ALL CONTROLS SHOWN IN
ICE MAKING MODE

9072107-01
REV A

1. Why does the Auger Motor delay 1 minute upon shut down?
2. True or False, The GEM/MFI Series uses a water level sensor.
3. True or False, GEM/MFI Series are designed to be stacked.
4. True or False, GEM/MFI Series self-contained air cooled machines need a minimum of 6 inches air clearance in the rear, sides and top of the machine.
5. Does a GEM/MFI Series machine need to be level?
6. Does a MFI Series machine qualify for a dispenser application?
7. True or False, GEM/MFI Series use infrared eyes for bin control.
8. Can you add a thermostatic bin control on the GEM/MFI Series as a secondary bin control?
9. When would a thermostatic bin control be necessary on a GEM/MFI Series application?
10. True or False, GEM/MFI Series units are designed to be installed indoors only.
11. True or False, GEM/MFI Series units do not need to be cleaned.
12. True or False, GEM/MFI Series units can use unpotable water to make ice because the machine purifies it.
13. RO water can be used as long as the microSiemens is no less than 35.
14. True or False, The water pressure should be between 20 and 80 psi.
15. True or False, Water softeners can be used with GEM/MFI Series units.
16. What amp draw will the Auger Motor Service Light trip at?
17. The GEM/MFI Series, if the Bin Full light is illuminated, it indicates what?
18. The GEM/MFI Series, if the Power Light is illuminated, it indicates what?
19. True or False, The GEM/MFI Series, a blinking Service Light indicates the unit is starting up or shutting down?
20. True or False, The GEM/MFI Series will auto restart on loss of water.
21. True or False, The GEM/MFI Series will auto restart on loss of power.
22. True or False, The GEM/MFI Series use a self-aligning upper bearing.
23. True or False, The GEM/MFI Series use a double flight auger.
24. True or False, You can bypass the water level sensor to ground for trouble shooting purposes.
25. What color should the grease on the upper bearing be?
26. How do you grease the lower bearing?
27. How do you perform a production check on a GEM/MFI Series?
28. How do you clean the evaporator on a GEM/MFI Series unit?
29. What is the direction of air flow on an air cooled GEM/MFI Series unit?
30. How does the GEM/MFI Series make ice, is it a shaver or does it make ice crystals and extrude through the top?