



ILLUSTRATED PARTS CATALOG

Designs, materials, weights, specifications, and dimensions for equipment or replacement parts are subject to change without notice.

Bunn-O-Matic Corporation

Post Office Box 3227, Springfield, Illinois 62708-3227

Phone (217) 529-6601 | Fax (217) 529-6644

Technical Support Phone (800) 420-2866

BUNN-O-MATIC COMMERCIAL PRODUCT WARRANTY

Bunn-O-Matic Corp. ("BUNN") warrants equipment manufactured by it as follows:

- 1) Airpots, thermal carafes, decanters, GPR servers, iced tea/coffee dispensers, MCR/MCP/MCA single cup brewers, thermal servers and ThermoFresh® servers (mechanical and digital) 1 year parts and 1 year labor.
- 2) All other equipment - 2 years parts and 1 year labor plus added warranties as specified below:
 - a) Electronic circuit and/or control boards - parts and labor for 3 years.
 - b) Compressors on refrigeration equipment - 5 years parts and 1 year labor.
 - c) Grinding burrs on coffee grinding equipment for 4 years or 40,000 pounds of coffee, whichever comes first.

These warranty periods run from the date of installation BUNN warrants that the equipment manufactured by it will be commercially free of defects in material and workmanship existing at the time of manufacture and appearing within the applicable warranty period. This warranty does not apply to any equipment, component or part that was not manufactured by BUNN or that, in BUNN's judgment, has been affected by misuse, neglect, alteration, improper installation or operation, improper maintenance or repair, non periodic cleaning and descaling, equipment failures related to poor water quality, damage or casualty. In addition, the warranty does not apply to replacement of items subject to normal use including but not limited to user replaceable parts such as seals and gaskets. This warranty is conditioned on the Buyer 1) giving BUNN prompt notice of any claim to be made under this warranty by telephone at (217) 529-6601 or by writing to Post Office Box 3227, Springfield, Illinois 62708-3227; 2) if requested by BUNN, shipping the defective equipment prepaid to an authorized BUNN service location; and 3) receiving prior authorization from BUNN that the defective equipment is under warranty.

THE FOREGOING WARRANTY IS EXCLUSIVE AND IS IN LIEU OF ANY OTHER WARRANTY, WRITTEN OR ORAL, EXPRESS OR IMPLIED, INCLUDING, BUT NOT LIMITED TO, ANY IMPLIED WARRANTY OF EITHER MERCHANTABILITY OR FITNESS FOR A PARTICULAR PURPOSE. The agents, dealers or employees of BUNN are not authorized to make modifications to this warranty or to make additional warranties that are binding on BUNN. Accordingly, statements by such individuals, whether oral or written, do not constitute warranties and should not be relied upon.

If BUNN determines in its sole discretion that the equipment does not conform to the warranty, BUNN, at its exclusive option while the equipment is under warranty, shall either 1) provide at no charge replacement parts and/or labor (during the applicable parts and labor warranty periods specified above) to repair the defective components, provided that this repair is done by a BUNN Authorized Service Representative; or 2) shall replace the equipment or refund the purchase price for the equipment.

THE BUYER'S REMEDY AGAINST BUNN FOR THE BREACH OF ANY OBLIGATION ARISING OUT OF THE SALE OF THIS EQUIPMENT, WHETHER DERIVED FROM WARRANTY OR OTHERWISE, SHALL BE LIMITED, AT BUNN'S SOLE OPTION AS SPECIFIED HEREIN, TO REPAIR, REPLACEMENT OR REFUND.

In no event shall BUNN be liable for any other damage or loss, including, but not limited to, lost profits, lost sales, loss of use of equipment, claims of Buyer's customers, cost of capital, cost of down time, cost of substitute equipment, facilities or services, or any other special, incidental or consequential damages.

392, A Partner You Can Count On, Air Infusion, AutoPOD, AXIOM, BrewLOGIC, BrewMETER, Brew Better Not Bitter, BrewWISE, BrewWIZARD, BUNN Espresso, BUNN Family Gourmet, BUNN Gourmet, BUNN Pour-O-Matic, BUNN, BUNN with the stylized red line, BUNNlink, Bunn-OMatic, Bunn-O-Matic, BUNNserve, BUNNSERVE with the stylized wrench design, Cool Froth, DBC, Dr. Brew stylized Dr. design, Dual, Easy Pour, EasyClear, EasyGard, FlavorGard, Gourmet Ice, Gourmet Juice, High Intensity, iMIX, Infusion Series, Intellisteam, My Café, Phase Brew, PowerLogic, Quality Beverage Equipment Worldwide, Respect Earth, Respect Earth with the stylized leaf and coffee cherry design, Safety-Fresh, savemycoffee.com, Scale-Pro, Silver Series, Single, Smart Funnel, Smart Hopper, SmartWAVE, Soft Heat, SplashGard, The Mark of Quality in Beverage Equipment Worldwide, ThermoFresh, Titan, trifacta, TRIFECTA (stylized logo), Velocity Brew, Air Brew, Beverage Bar Creator, Beverage Profit Calculator, Brew better, not bitter., Build-A-Drink, BUNNSource, Coffee At Its Best, Cyclonic Heating System, Daypart, Digital Brewer Control, Element, Milk Texturing Fusion, Nothing Brews Like a BUNN, Picture Prompted Cleaning, Pouring Profits, Signature Series, Sure Tamp, Tea At Its Best, The Horizontal Red Line, Ultra are either trademarks or registered trademarks of Bunn-O-Matic Corporation. The commercial trifacta® brewer housing configuration is a trademark of Bunn-O-Matic Corporation.

TABLE OF CONTENTS

Frame, Panels and Drip Trays.....	4
Front Panel Components.....	6
Hopper Assembly.....	8
Electrical Components	10
Refrigeration	12
Compressor R290.....	16
CFV Platform Assembly - Housing	18
CFV Assembly - Valves.....	20
LAF Platform Assembly - Housing	22
LAF Assembly - Valves.....	24
Power Cords & Wiring Harnesses.....	26

TIPS:



To **Search/Find** content in this document, use "**Ctrl+F**" (PC)



To **Search/Find** content in this document, use "**Command+F**" (Mac)

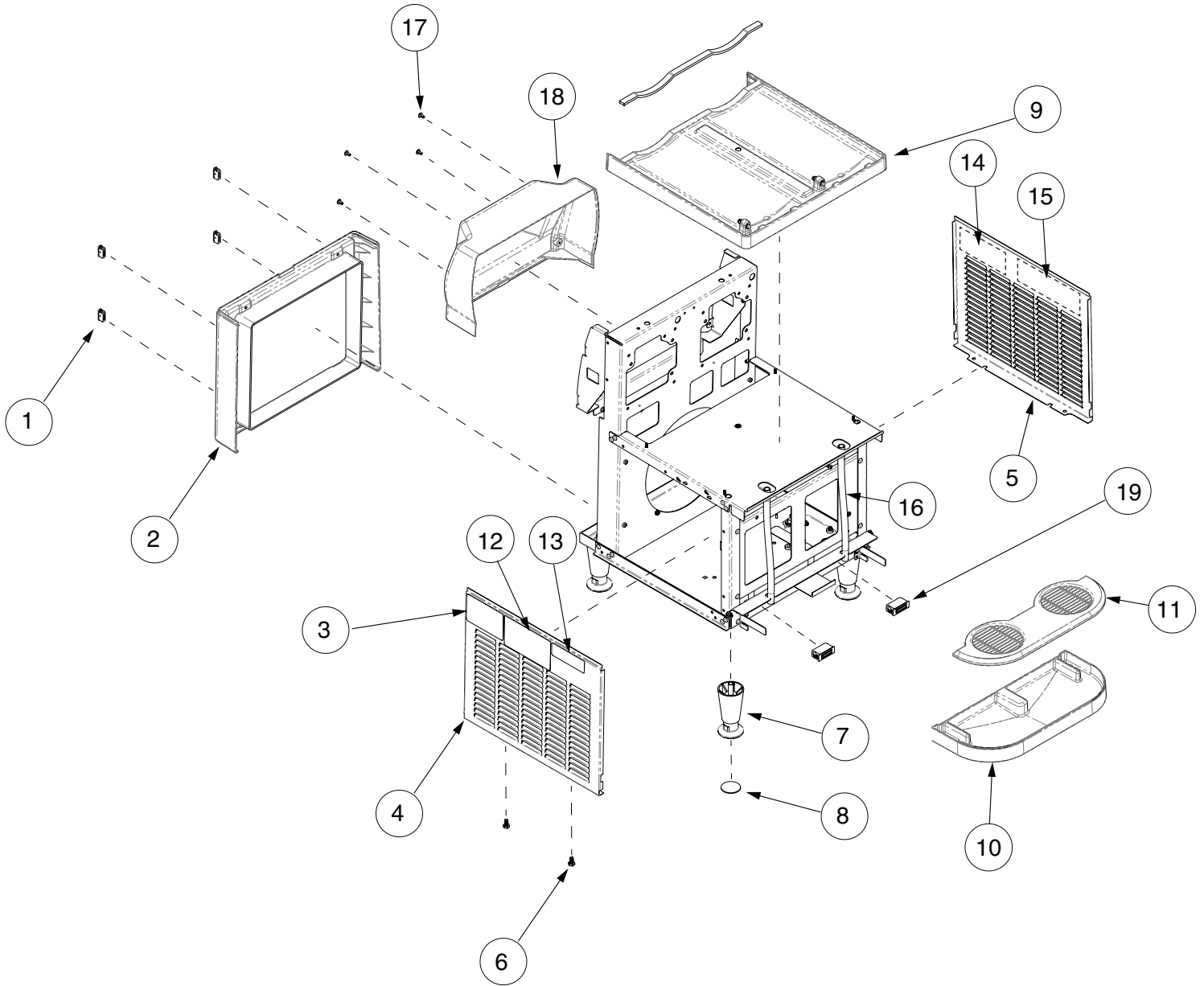

FRAME, PANELS AND DRIP TRAYS

ITEM	QTY	DESCRIPTION	PART NO.	NOTES
1	4	CATCH, MAGNETIC-SNAP IN	21436.0000	
2	1	FRAME, FILTER MTG ULTRA NX - BLK	57579.0001	
3	1	DATAPLATE, LABEL		
4	1	PNL W/DECALS,LEFT SIDE SST 120V	58192.0000	
	1	PNL W/DECALS,LEFT SIDE SST 230V	58192.0001	
	1	PNL W/DECALS,LEFT SIDE BLK 120V	58192.0003	
	1	PNL W/DECALS,LEFT SIDE BLK 230V	58192.0004	
5	1	PNL W/DECALS,RIGHT SIDE SST	58192.0002	
	1	PNL W/DECALS,RIGHT SIDE BLK	58192.0005	
6	2	SCREW, HEX HD .25-20 X .50	37549.0000	
7	4	LEG, NICKEL PLATED	40041.0000	
8	4	PAD, ANTI SKID	40042.0000	
9	2	DRIP TRAY, HOPPER ULTRA NX - WHT	56779.0000	
	2	DRIP TRAY, HOPPER ULTRA NX - BLK	56779.0001	
10	1	DRIP TRAY BASE, ULTRA NX - WHT	57659.1000	
		DRIP TRAY BASE, ULTRA NX - BLK	57659.1001	
11	1	DRIP TRAY COVER, ULTRA NX - WHT	57660.0000	
	1	DRIP TRAY COVER, ULTRA NX - BLK	57660.0001	
12	1	DECAL, WARNING ULTRA NX	57864.0000	
13	1	DECAL, RFGT CHARGE 120V R290	29373.0005	
14	1	DECAL, DANGER R-290 REPAIR ONLY	57862.0000	
15	1	DECAL, CAUTION R-290 ULTRA NX	57863.0000	
16	2	TUBE,CLEAR FLEX.375IDx10.50		Order item 20
17	1	SCREW, TRH SLTD BLK 8-32x.375 LKG	01317.0005	
18	1	MOTOR COVER, AUGER ULTRA NX - WHT	56652.1000	
		MOTOR COVER, AUGER ULTRA NX - BLK	56652.1001	
		MOTOR COVER, AUGER ULTRA NX - WHT CFV	56652.1002	
		MOTOR COVER, AUGER ULTRA NX - BLK CFV	56652.1003	
		MOTOR COVER, AUGER ULTRA NX - BLK LAF	56652.1005	
19	2	CATCH MAGNET	21436.1000	
THE FOLLOWING PARTS ARE NOT ILLUSTRATED:				
20	-	TUBE,CLEAR FLEX-.375IDx12.0LG	12421.1001	
	-	TUBE, CLEAR FLEX-.375IDx60.0LG	12421.1002	
	-	TUBE,CLEAR FLEX-.375IDx180LG	12421.1004	

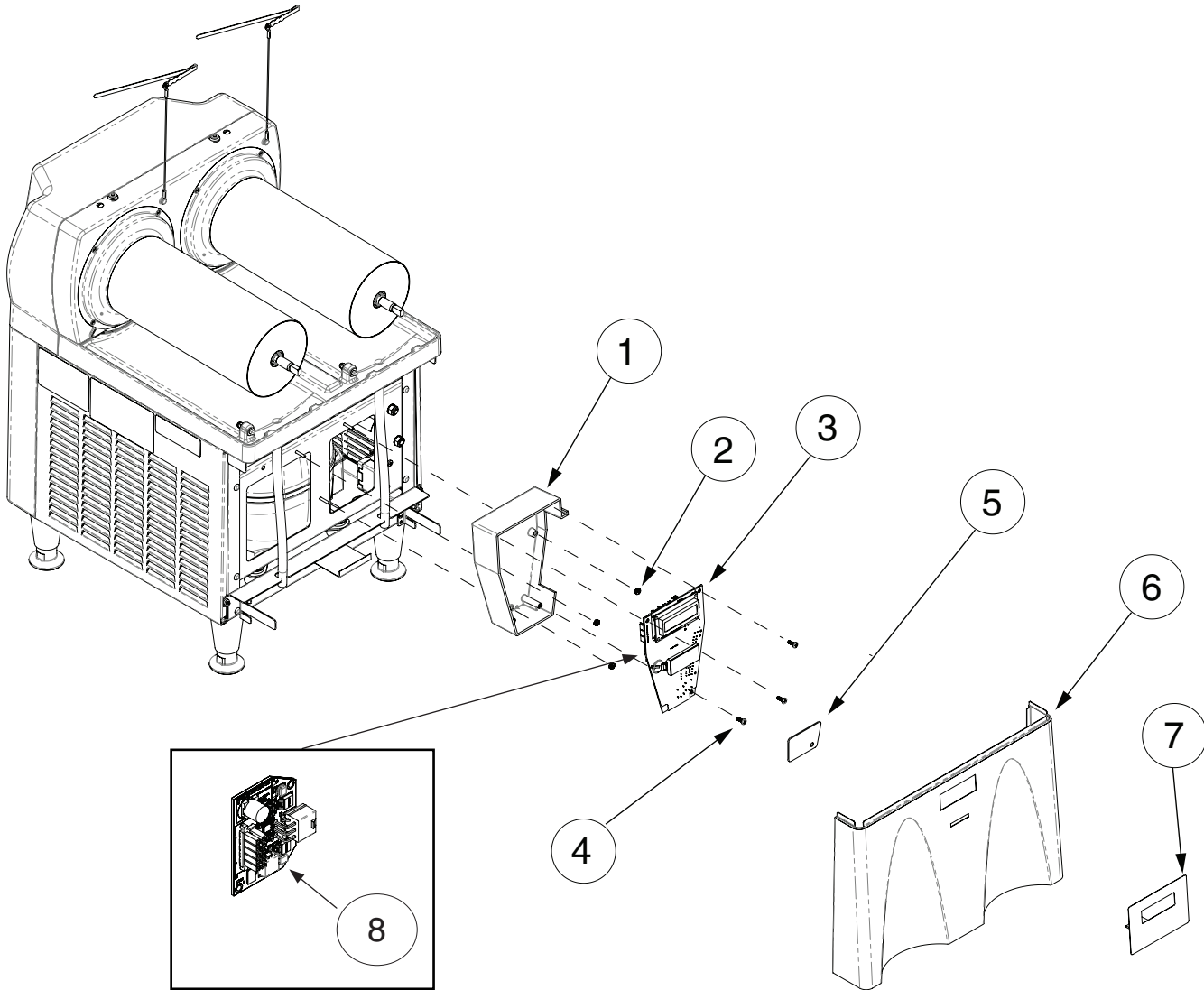

FRONT PANEL COMPONENTS

ITEM	QTY	DESCRIPTION	PART NO.	NOTES
1	1	HOUSING, ELECTRONIC CONTROL ULTRA NX	32121.0001	
2	3	NUT, KEPS 6-32 ZINC PLATE	00973.0000	
3	1	CBA KIT, ULTRA NX MAIN	57667.1000	
4	3	SCREW, PNH PHH #8-18 TRI-LOBE	24544.0000	
5	1	SHIELD, CBA MAIN ULTRA NX	58348.0000	
6	1	PANEL, FRONT ULTRA-2 BLACK	32116.1001	
	1	PANEL, FRONT ULTRA-2 SST	32116.1000	
7	1	KIT, SWITCH MEMBRANE ULTRA-2 BLACK	32126.1006	
8	1	CBA KIT, AUTO FILL ULTRA NX	57675.1000	For CFV and LAF Bases

HOPPER ASSEMBLY

ITEM	QTY	DESCRIPTION	PART NO.	NOTES
1	2	SEAL, COOLING DRUM HOPPER MTG	32079.0001	
2	2	COVER, HOPPER BLACK ULTRA NX	57588.0001	
		COVER, HOPPER WHITE ULTRA NX	57588.0000	
3	2	LINER, HOPPER COVER ULTRA NX	57587.0000	
4	2	HOPPER, ULTRA NX 3 GAL	32190.1016	Includes item 9
	2	HOPPER, ULTRA NX CFV / LAF	32190.1017	Includes item 9
	2	HOPPER, ULTRA NX PAF	32190.1011	Includes item 9
5	2	SEAL, AUGER SHAFT	26780.0000	Requires item 22
6	2	SPRING,COMP .072x.72DIAx3.0LG	32193.0000	
7	2	KIT, FAUCET SEALS - ULTRA, 2 SEALS	32268.1000	
	-	KIT, FAUCET SEALS ULTRA, 1 SEAL	32268.1001	
8	2	AUGER, HOPPER ULTRA-2	32106.0000	
9	2	BUSHING, HOPPER-AUGER NOSE	32189.0000	
10	2	VALVE, FAUCET FROZEN BLACK ULTRA NX	57793.0000	
11	2	HANDLE, EXTENDED ULTRA NX BLK NYLON AM	44614.0004	
12	2	SCREW, TRH-SLTD #8-32	01317.0000	
13	1	CBA & MAG CORD ASSY, LED-ULTRA HPR COVER	47297.0001	
14	2	PLUNGER ASSY, HOPPER LOCK	29702.1000	
15	1	DRUM ASSY, EVAP COATED FOAMED ULTRA NX	56765.0001	
16	1	MOUNT, COOLING DRUM ULTRA NX - WHT	56651.0000	
	1	MOUNT, COOLING DRUM ULTRA NX - BLK	56651.0001	
17	2	MAG CONTACT BASE	27643.0003	
18	2	BUSHING, HOPPER - AUGER	26781.0000	
19	2	SEAL, COOLING DRUM TO SHAFT .270 THK	37593.0001	
20	1	TOOL, COOLING DRUM SEAL INSERTION	57751.0000	Included in item 25
21	2	SUPPORT, EVAPORATOR	28027.0000	Included in item 25
	2	LID ASSY, DISPLAY HOPPER WHITE	57678.1000	Includes item 2,3,13
	2	LID ASSY, DISPLAY HOPPER BLACK	57678.1001	Includes item 2,3,13
	2	COVER ASSY, HOPPER-FLAT-ULTRA	29481.0001	
THE FOLLOWING PARTS ARE NOT ILLUSTRATED:				
22	-	LUBRIFILM TUBES, 4OZ HAYNES	M2550.0000	
23	-	LUBRIFILM TUBES, 1 OZ HAYNES	M2550.0001	
24	-	KIT, KRYTOX GREASE .085 OZ.	29563.0000	
25	1	KIT, PM ULTRA NX	58054.0000	Includes item 1, 5, 7,18, 19, 20, 21, 22 & 24

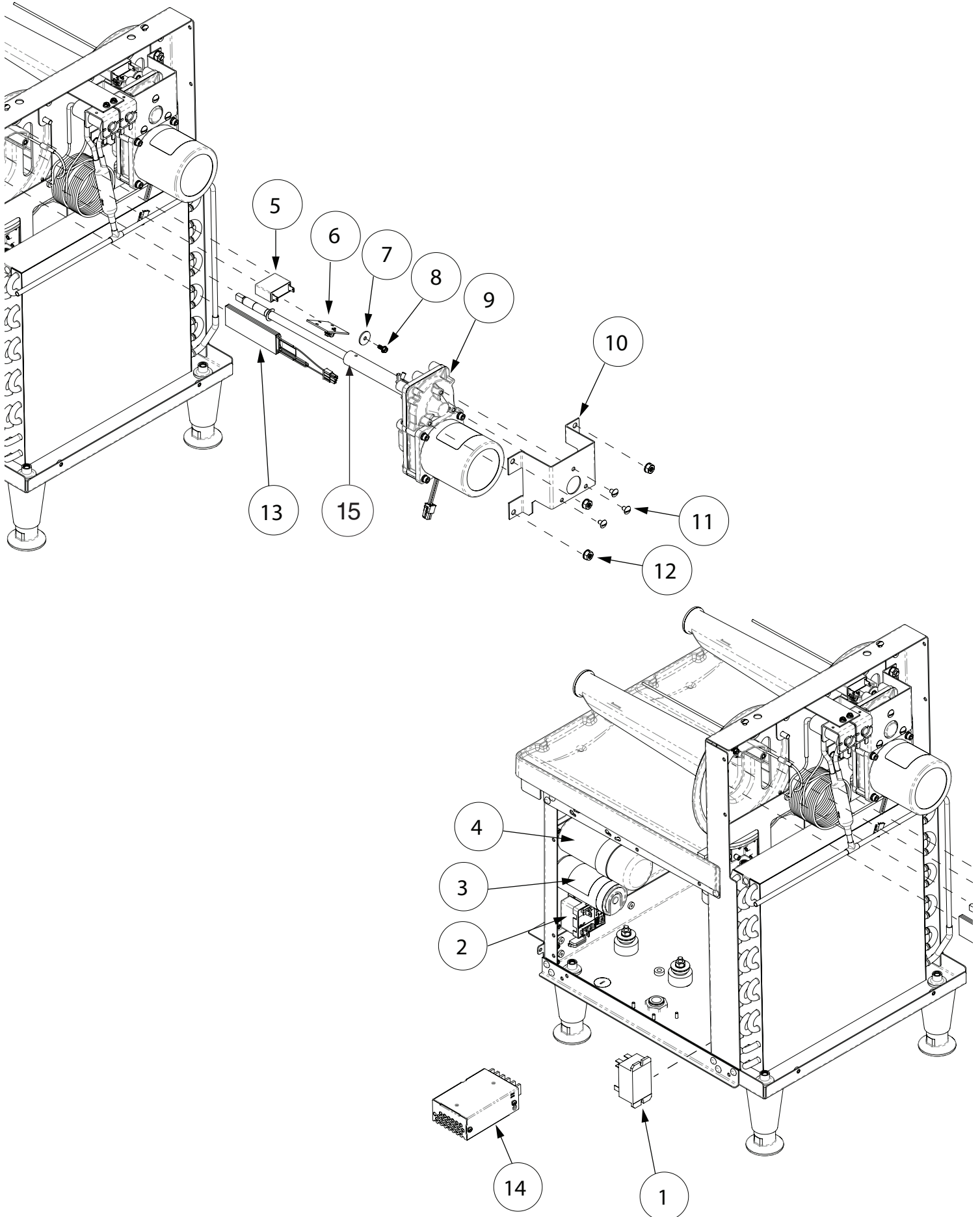

ELECTRICAL COMPONENTS

ITEM	QTY	DESCRIPTION	PART NO.	NOTES
1	1	RELAY, 40A DPST NO 24VDC	57775.0000	
2	1	RELAY, COMPRESSOR START 115V	57641.0000	
		RELAY, COMPRESSOR START 230V	57641.0001	
3	1	CAPACITOR, START 115-127V	57642.0000	
		CAPACITOR, START 220-240V	57642.0001	
4	1	CAPACITOR ASSY, RUN 115V	57643.0000	
		CAPACITOR ASSY, RUN 220-240V	57643.0001	
5	2	CAPACITOR, 250 VAC	27178.0000	
		CAPACITOR, 500 VAC	27178.0001	
6	2	CBA, POSITION SENSOR	38708.0000	
7	1	WASHER,NKL PL-.188IDx.75ODx.06	02360.0000	
8	1	SCREW,PNHSLTD W/SERR 8-32x.38	02308.0000	
9	2	AUGER MOTOR (120V) .188 PIN	28093.1015	
		AUGER MOTOR (230V) .188 PIN	28093.1016	
10	2	BRACKET, MOTOR MTG ULTRA NX	27232.0002	
11	6	SCREW, TRH LKG PATCH 10-32x.31	01326.0002	
12	6	NUT, KEPS .25-20 ZINC PLTD	23700.0000	
13	1	HEATER, PTC 120V ULTRA NX	57625.1002	includes 0.2oz of heat sink compound
	1	HEATER, PTC 230V ULTRA NX	57625.1003	includes 0.2oz of heat sink compound
14	1	POWER SUPPLY, 24VDC 1.1A 26.4W 1 PHASE	33363.0013	
15	2	SHAFT ASSY, AUGER DRIVE - .188 PIN ULTRA	28081.0003	
THE FOLLOWING PARTS ARE NOT ILLUSTRATED:				
16	-	HEAT SINK COMPOUND, 5 OZ TUBE	M2522.1000	
17	-	GREASE,KRYTOX GPL-205(.50 OZ)	M2548.1000	
18	2	SENSOR ASSEMBLY KIT, TEMPERATURE	27246.1000	

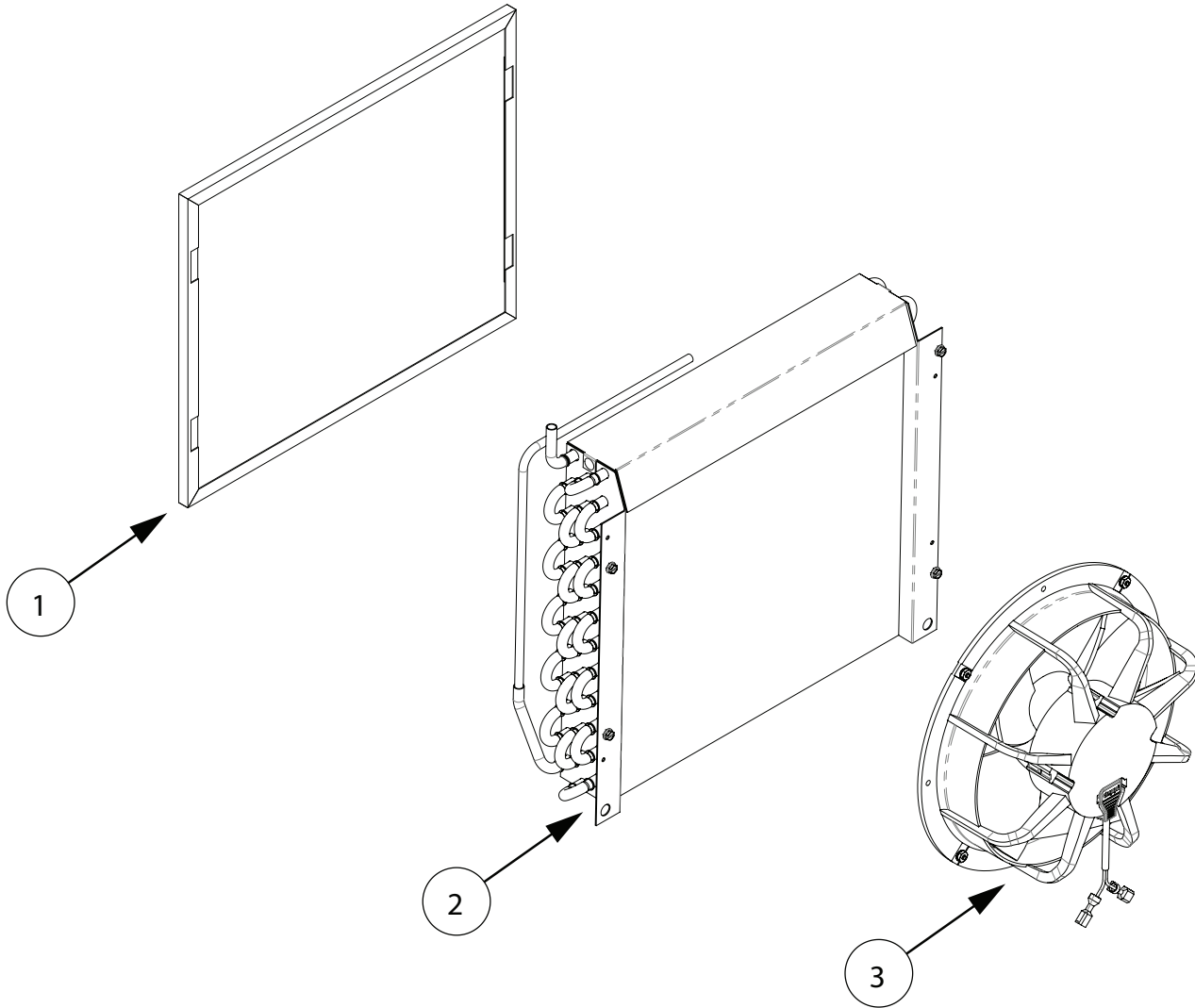

REFRIGERATION

ITEM	QTY	DESCRIPTION	PART NO.	NOTES
1	1	GRILL, FILTER	28122.0002	
2	1	CONDENSER 12 X 12 X 1.875"	56751.0000	
3	1	FAN, 200 MM 120VAC	57598.0000	
	1	FAN, 200 MM 230VAC	57598.0001	

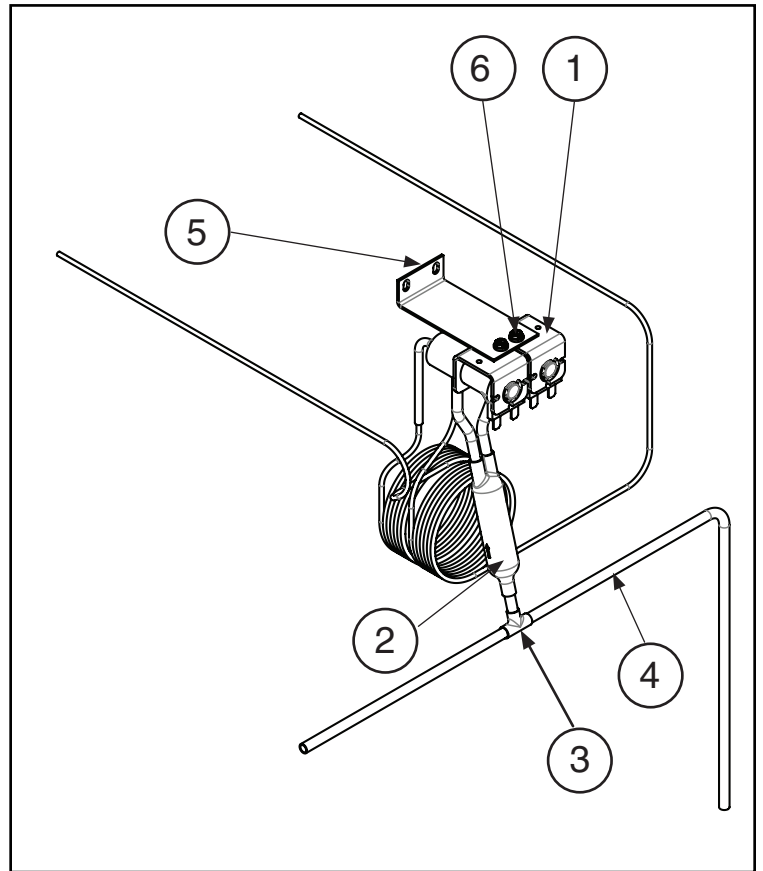
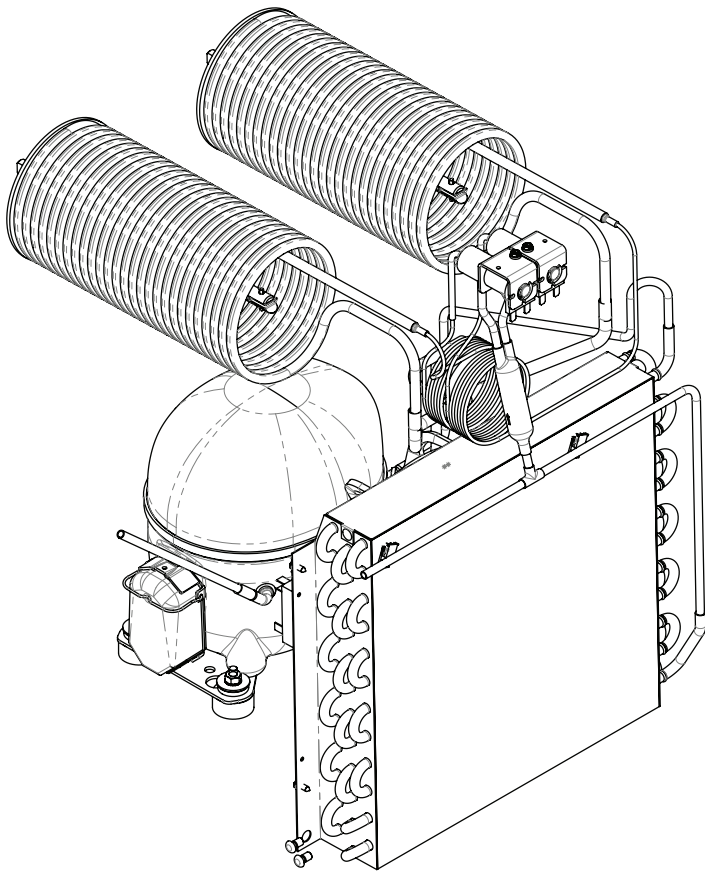

REFRIGERATION

ITEM	QTY	DESCRIPTION	PART NO.	NOTES
1	2	VALVE ASSEMBLY, R290 SOLENOID 120V	32133.0003	
		VALVE ASSEMBLY, R290 SOLENOID 230V	32133.0004	
2	1	DRYER ASSY, FILTER .250 ID 1 IN/2 OUT	32256.0003	
3	1	TEE, CU-SOLDER .25 OD TUBE	00467.0000	
4	1	TUBE, COND TO FILTER/DRYER ULTRA NX	57649.0000	
5	1	BRACKET, REFRIG SOLENOID MTG ULTRA NX	32112.0004	
6	2	SCREW,HEX CRIMPTITE"AB"#6x.25	02332.0001	

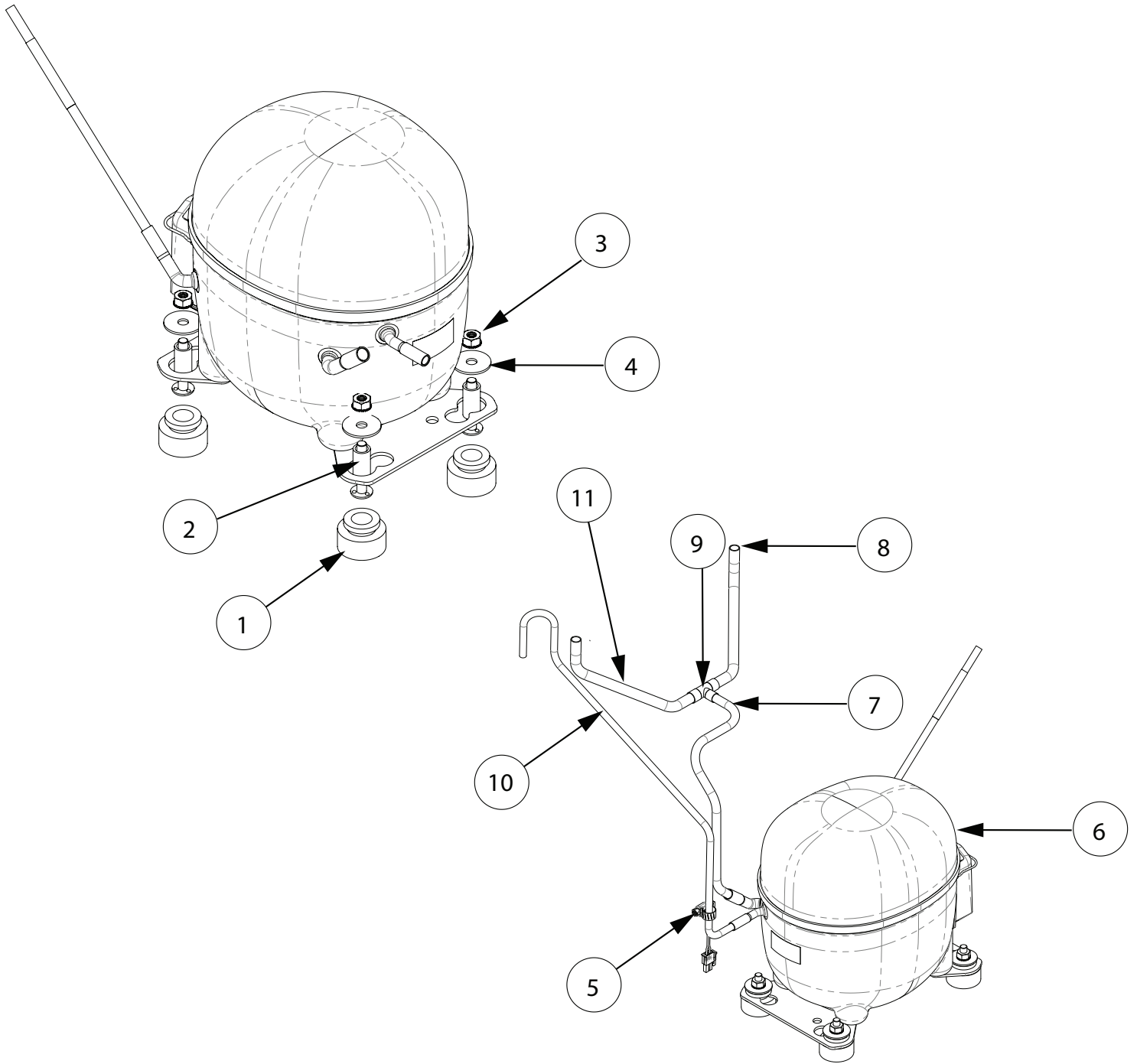

COMPRESSOR R290

ITEM	QTY	DESCRIPTION	PART NO.	NOTES
1	4	GROMMET, COMPRESSOR MOUNT	32797.0000	
2	4	SLEEVE,COMPRESSOR MTG EMBRACO	32798.0000	
3	4	NUT, KEPS .25-20 ZINC PLTD	23700.0000	
4	4	WASHER, .281 IDX 1.00 OD SST	21431.0003	
5	1	CLAMP, WORM-DRIVE .125/.312	29421.0001	
6	1	COMPRESSOR, NEX4170UA 115-127V 60 HZ embraco)	57640.1000	
	1	COMPRESSOR, NEU2178U 220-240V 50 HZ (embraco)	57640.1001	
7	1	TUBE, SUCTION COMP	57647.0000	
8	1	TUBE, SUCTION EVAP RIGHT	57648.0000	
9	1	TEE, SOLDER- TYPE .375 X .375 X .312 OD	00396.0003	
10	1	TUBE, COP .250OD DISCHARGE	57646.0000	
11	1	TUBE, SUCTION EVAP LEFT	57648.0001	
THE FOLLOWING PARTS ARE NOT ILLUSTRATED:				
12	1	PROBE, NTC THERMISTOR	32269.0000	Installed by item 5

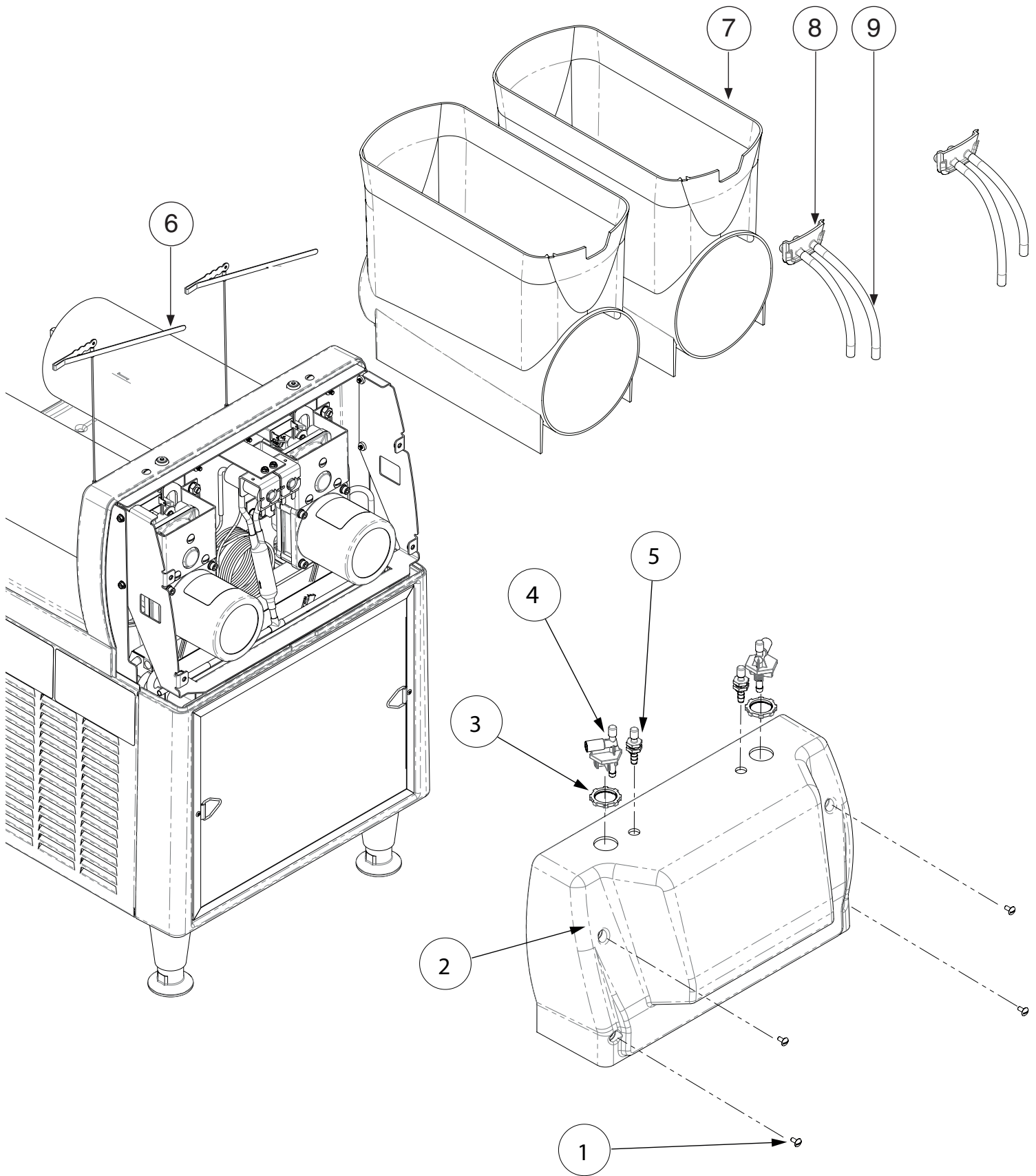

CFV PLATFORM ASSEMBLY - HOUSING

ITEM	QTY	DESCRIPTION	PART NO.	NOTES
1	4	SCREW, HEX HD WASH	44408.0000	
2	1	MOTOR COVER ASSY, AUGER ULTRA - BLK CFV	58045.1003	
	1	MOTOR COVER ASSY, AUGER ULTRA - WHT CFV	58045.1002	
3	2	LOCKNUT, .75-14 NPSM THD	45042.0000	
4	2	VALVE ASSY, NEEDLE .250 BULKHEAD		
	2	SCREW, NEEDLE VALVE .3125 BULKHEAD	43117.0000	part of item 4
	2	O-RING, -005 EP 70	24733.0016	part of item 4
	1	LUBE, SILICONE HAYNES 1OZ TUBE	44023.0001	used on item 4
5	2	FITTING, .250 BARB BULKHEAD-KYNAR	43121.0000	
6	2	KIT, PROBE ASSY ULTRA NX CF/LAF	58303.0000	
7	2	HOPPER, ULTRA NX CFV / LAF		Go to Hopper Assembly
8	2	FITTING, DUAL INLET ANGLED - ULTRA CFV/LAF	43823.0002	
9	4	TUBING, SILICONE .188IDx.313 OD X 7.0LG		Order item 10
THE FOLLOWING PARTS ARE NOT ILLUSTRATED:				
10	-	KIT, TUBE SILICONE .188 IDx12.0 LG	41113.1000	
	-	KIT, TUBE SILICONE.188IDx36.0LG	41113.1001	
	-	KIT, TUBE SILICONE.188IDx120.0LG	41113.1002	

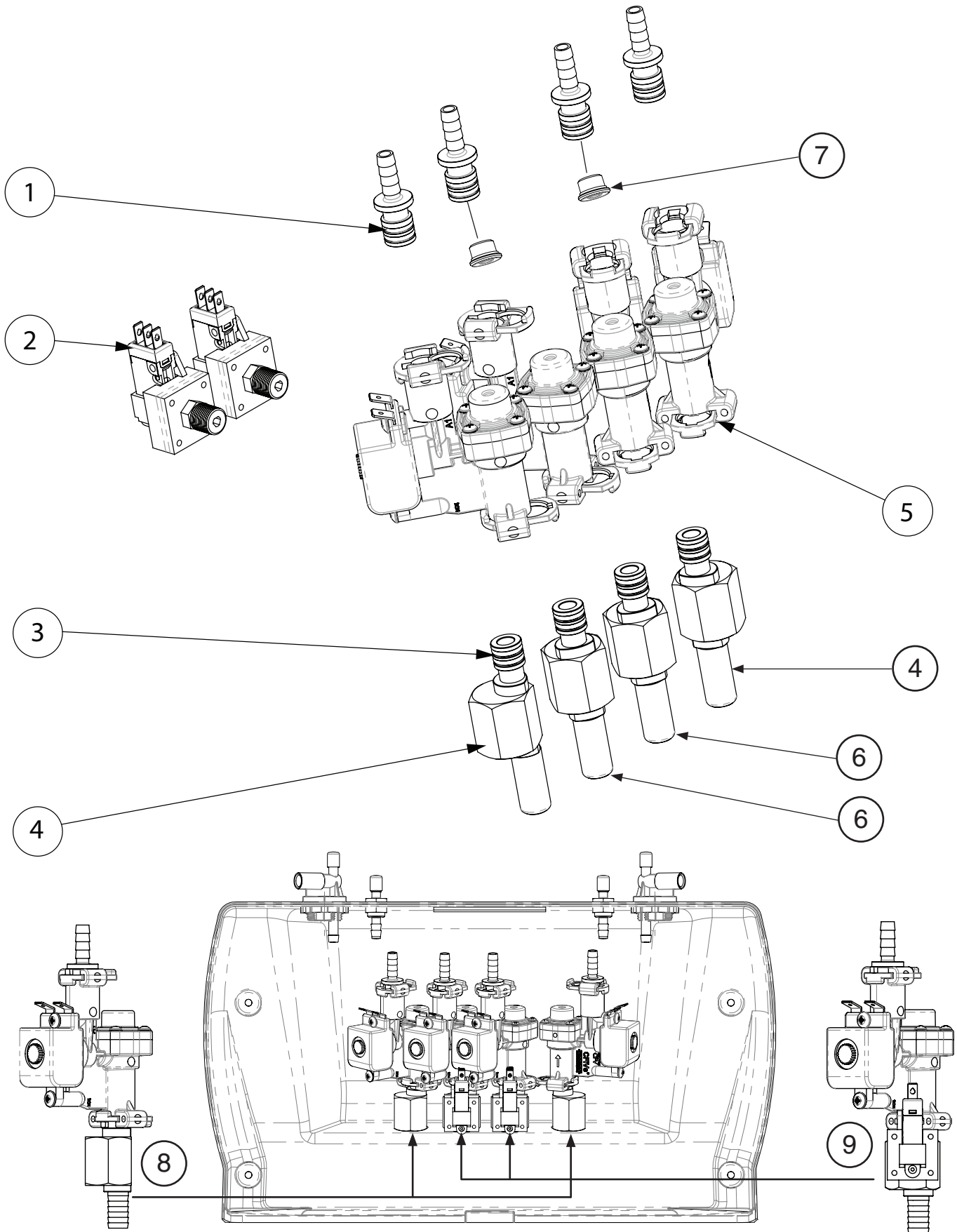

CFV ASSEMBLY - VALVES

ITEM	QTY	DESCRIPTION	PART NO.	NOTES
1	4	FITTING, CFIVE .25 BARB	57629.0000	
2	2	SWITCH, PRESSURE	44011.0003	
3	8	O-RING, -012 EP 70	24733.0019	
4	2	FITTING, CFIVE MOUNTING	56814.0001	
5	3	CF SOLENOID VALVE, 24VDC CF CFIVE	57628.0000	
6	2	FITTING, CFIVE MOUNTING PRESSURE	56814.0000	
7	2	ORIFICE, CFIVE .035 WHITE	57629.0002	
	2	ORIFICE, CFIVE .047 BLACK	57629.0001	
8	2	CFV CFIVE ASSY, NO ORIFICE ULTRA NX	57627.0000	
9	2	CFV CFIVE ASSY, .035 ORIFICE ULTRA NX	57627.0002	
	2	CFV CFIVE ASSY, .047 ORIFICE ULTRA NX	57627.0001	
THE FOLLOWING PARTS ARE NOT ILLUSTRATED:				
10	4	TUBE,SILICONE-.250ID X 7.25LG		Order item 11,12 or 13
11	-	TUBE,SILICONE-.25ID X 12.0"LG	11707.1000	
12	-	TUBE,SILICONE-.25ID x 36.0"LG	11707.1001	
13	-	TUBE,SILICONE-.25ID X 120.0"LG	11707.1002	
14	8	CLAMP, SST-.425/.523 DIA13.3	21275.0001	

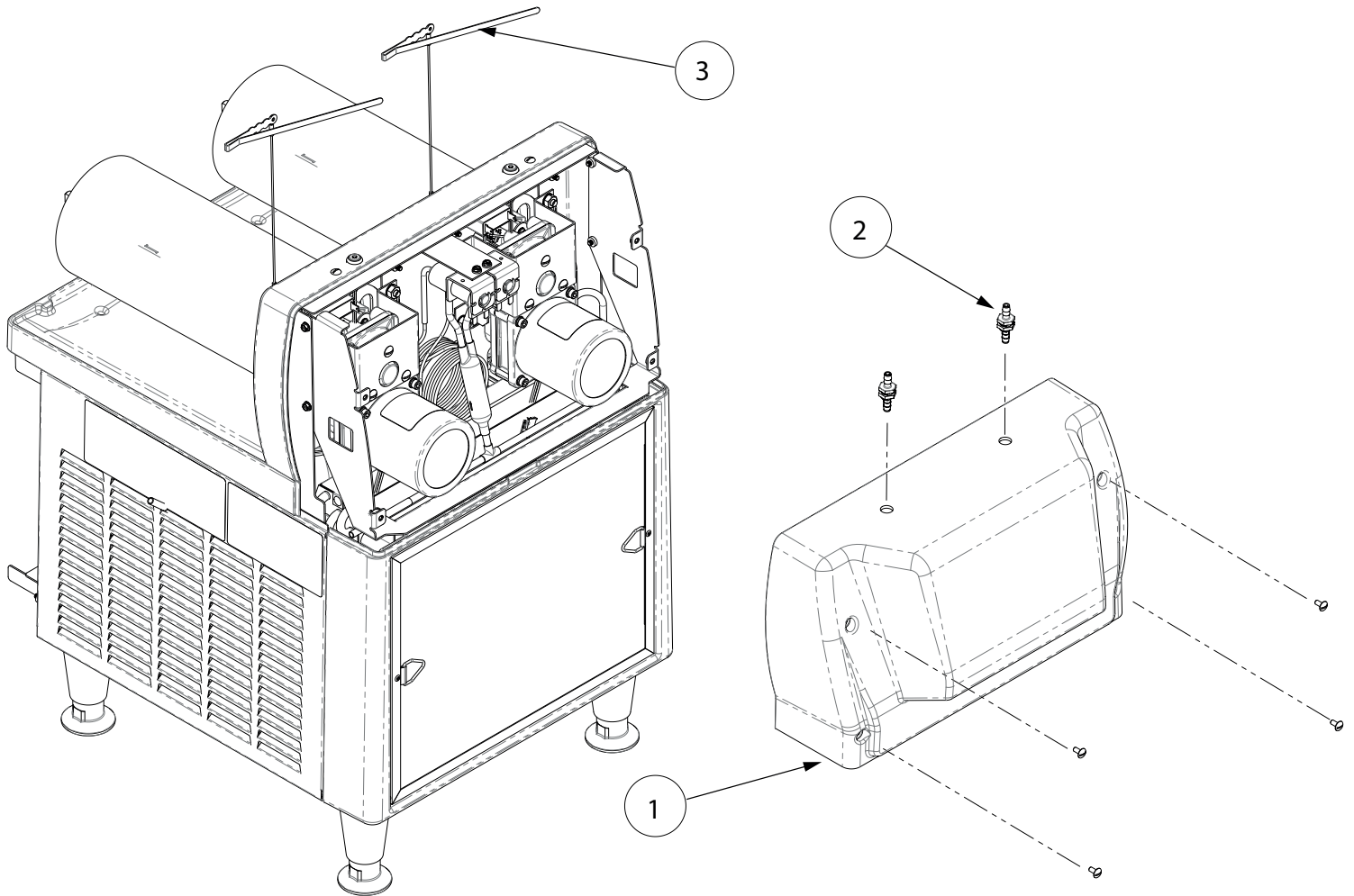

LAF PLATFORM ASSEMBLY - HOUSING

ITEM	QTY	DESCRIPTION	PART NO.	NOTES
1	1	MOTOR COVER, LAF BLK	58045.1005	
2	2	FITTING, .250 BARB BULKHEAD-KYNAR	43121.0000	
3	2	KIT, PROBE ASSY ULTRA NX CF/LAF	58303.0000	

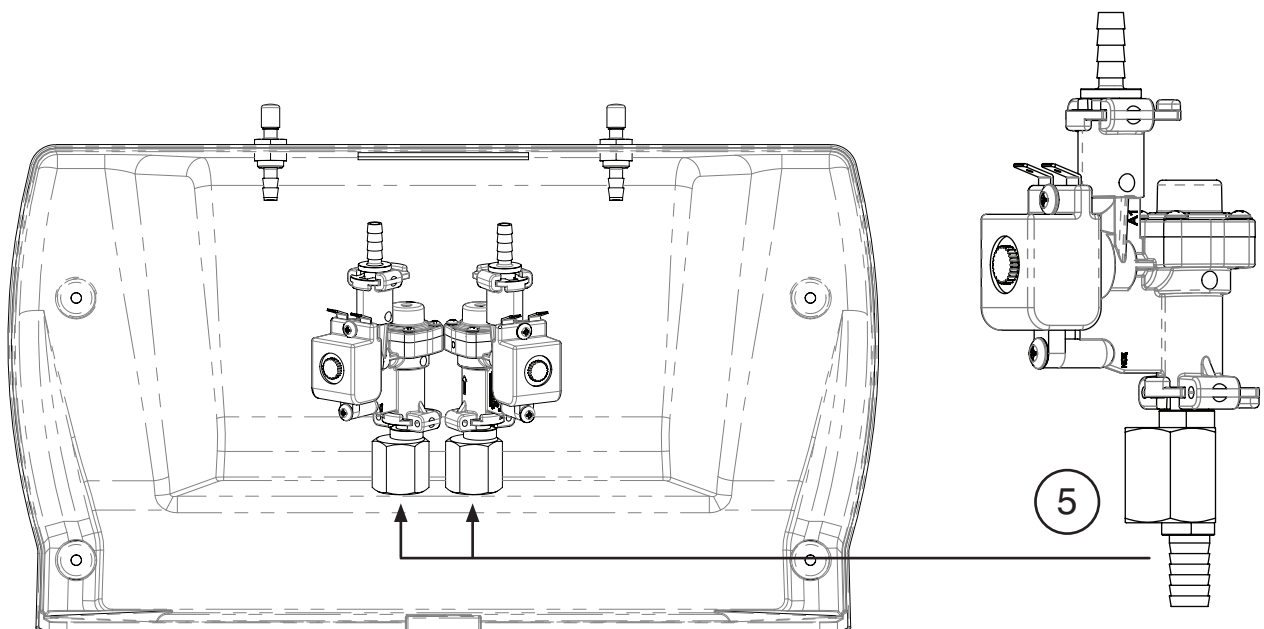
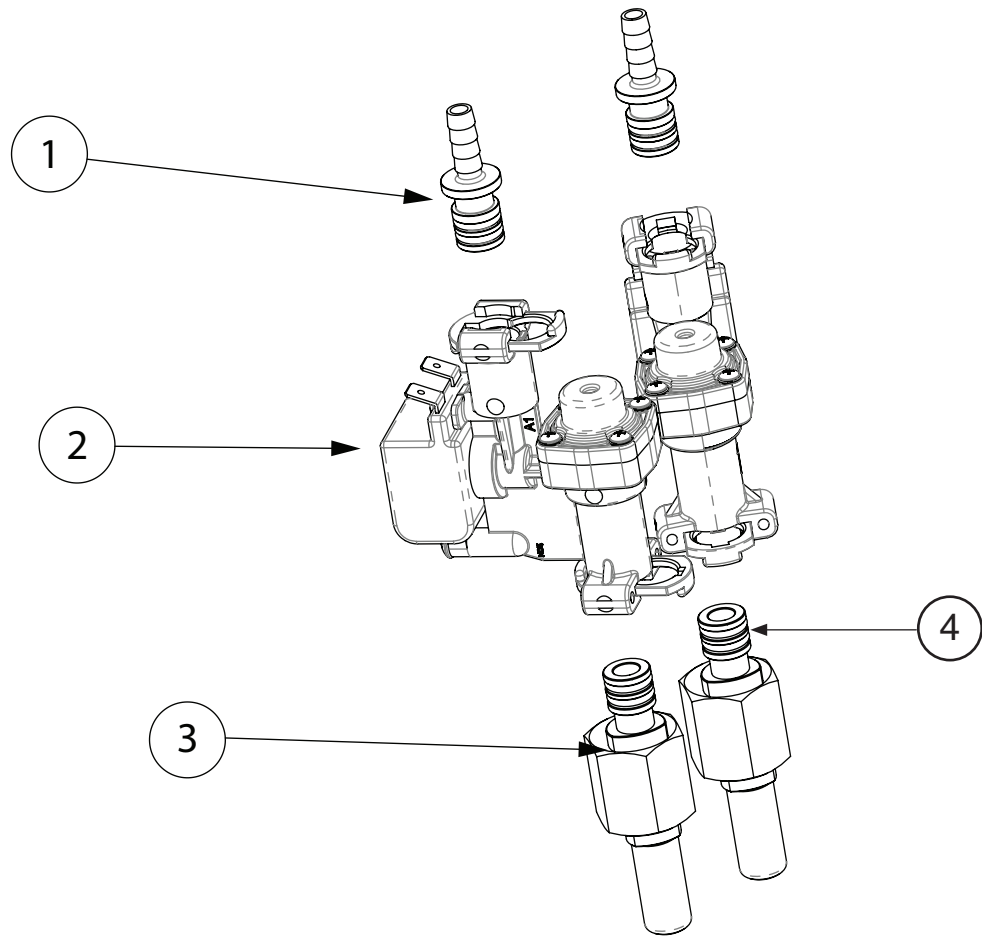

LAF ASSEMBLY - VALVES

ITEM	QTY	DESCRIPTION	PART NO.	NOTES
1	2	FITTING, CFIVE .25 BARB	57629.0000	
2	2	SOLENOID VALVE, 24VDC CFIVE	57628.0001	
3	2	FITTING, CFIVE MOUNTING	56814.0001	
4	4	O-RING, -012 EP 70	24733.0019	
5	2	LAF CFIVE ASSY, SOLENOID VALVE ULTRA NX	57627.0003	
THE FOLLOWING PARTS ARE NOT ILLUSTRATED:				
6	2	TUBE,SILICONE-.250ID X 7.25LG		Order item 7, 8 or 9
7	-	TUBE,SILICONE-.25ID X 12.0"LG	11707.1000	
8	-	TUBE,SILICONE-.25ID x 36.0"LG	11707.1001	
9	-	TUBE,SILICONE-.25ID X 120.0"LG	11707.1002	
10	4	CLAMP, SST-.425/.523 DIA13.3	21275.0001	

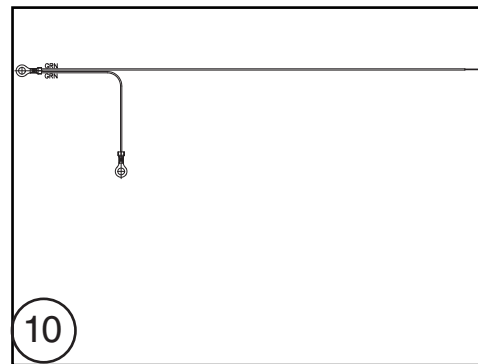
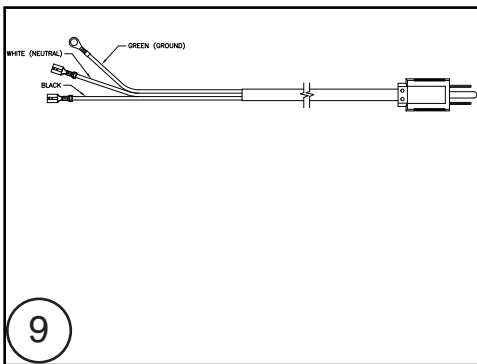
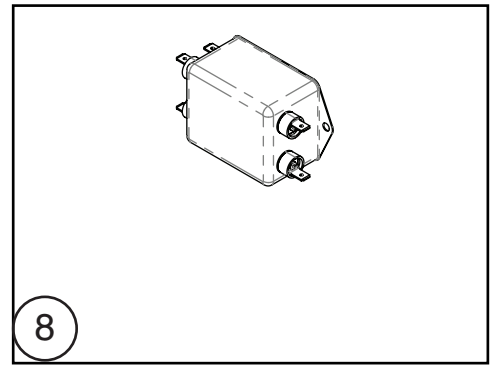
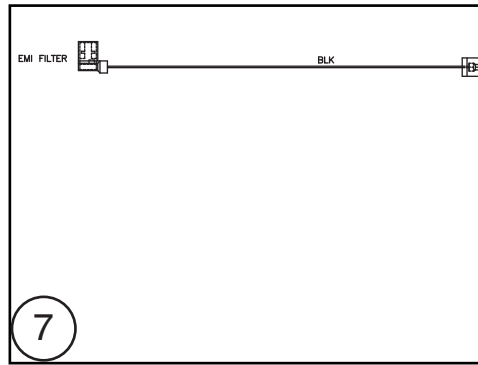
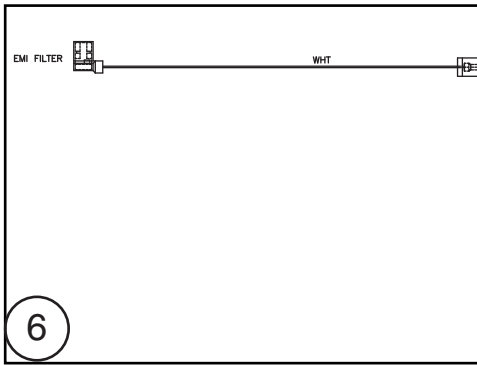
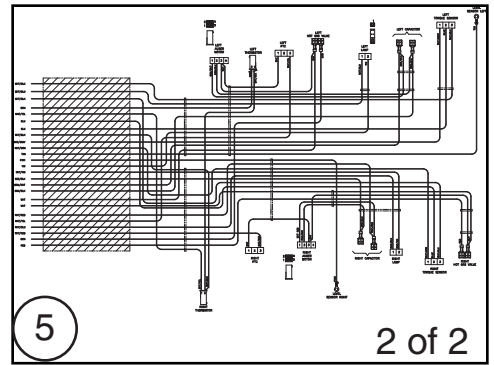
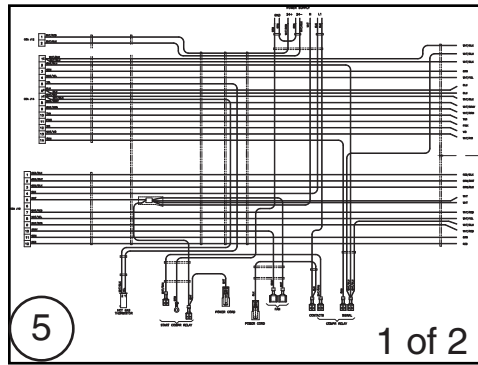
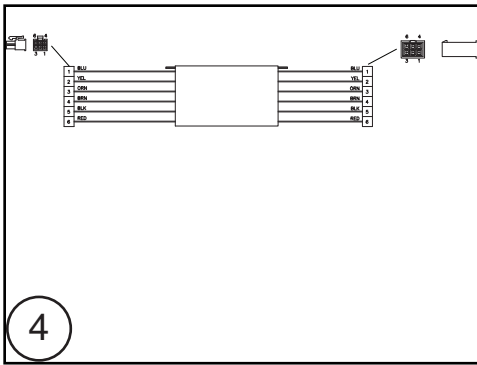
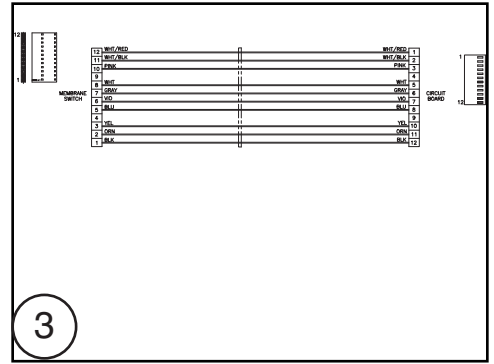
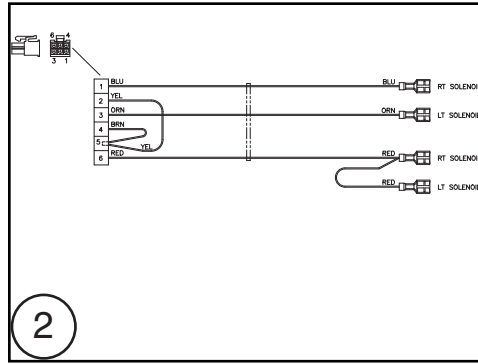
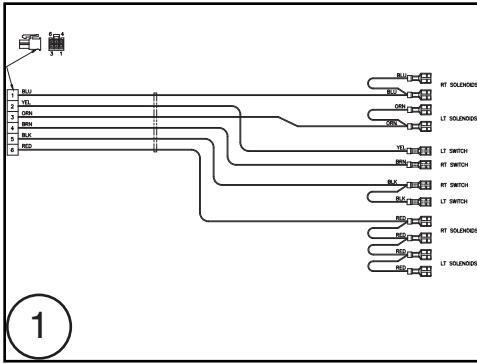

POWER CORDS & WIRING HARNESSSES

ITEM	QTY	DESCRIPTION	PART NO.	NOTES
1	1	WIRE HARNESS, MOTOR COVER ASSY CFV 120V & 220-240V BASE	43841.0002	Used in: NX Base/ CFV
2	1	WIRE HARNESS, MOTOR COVER ASSY LAF 120V & 220-240V BASE	43841.0003	Used in: NX Base/LAF
3	1	WIRING HARNESS,INTFC 120V & 220-240V BASE	32163.0000	Used in: NX Base Standard, CFV & LAF
4	1	WIRE HARNESS, CFV/LAF 120V & 220-240V BASE	37962.0004	Used in: NX Base CFV & LAF
5	1	WIRING HARNESS, MAIN 120V & 220-240V BASE	32263.0008	Used in: NX Base Standard, CFV & LAF
6	1	JUMPER,PWR CORD/EMI FLTR(WHT)	40432.0000	Used in: 220-240V LAF UK Base
7	1	JUMPER,PWR CORD/EMI FLTR(BLK)	40432.0001	Used in: 220-240V LAF UK Base
8	1	FILTER, EMI 10A 250VAC FASTON	29446.0006	Used in: Used in: Standard, CFV & LAF 220-240V Bases
9		POWER CORD ASSY, 16/3HSJO-15P 84	20630.0009	Used in: 120V Bases
10	1	WIRING HARNESS, GROUND ULTRA NX	58359.0000	Used in: 230V Bases

