



VIPER ELITE CARTS

FOR FROZEN CARBONATED BEVERAGE
DISPENSERS

VIPER ELITE 2 FLAVOR CART



VIPER ELITE 3 FLAVOR CART



VIPER ELITE 4 FLAVOR CART



FEATURES

Durability - Stainless steel side panels

Storage - Provides storage for syrup BIB and BIB pumps

Mobility - Includes casters

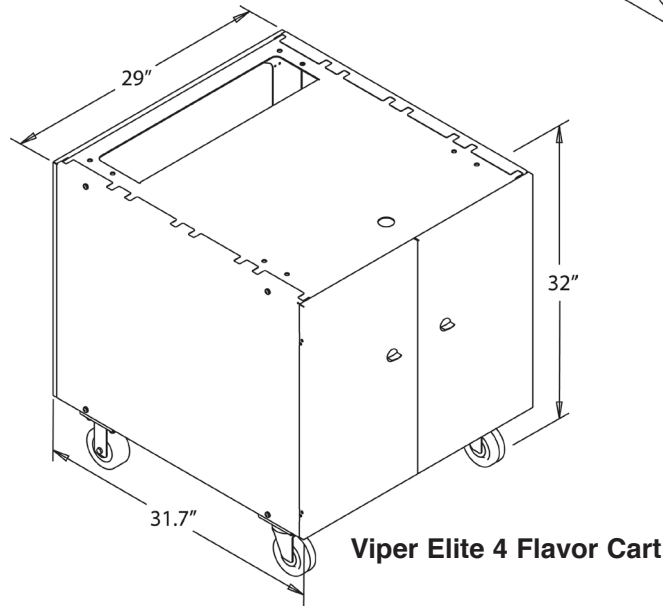
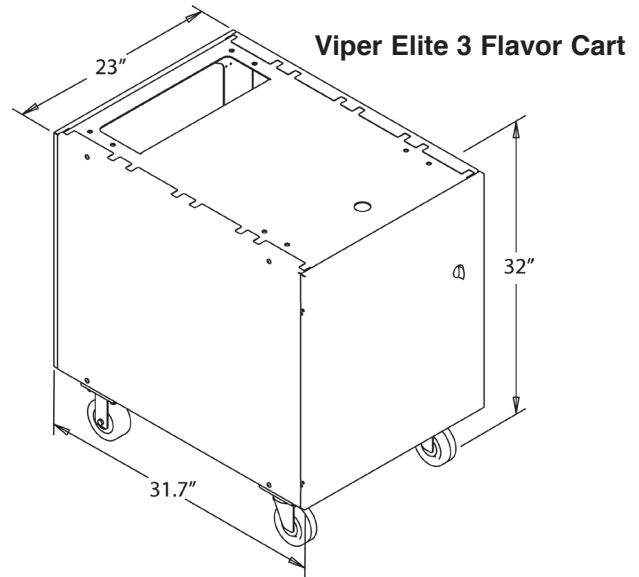
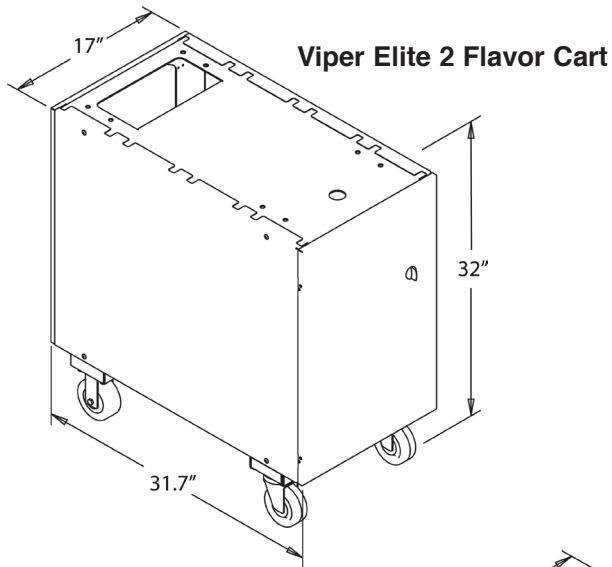

PART NUMBER	DESCRIPTION
620043075	Viper Elite 2 Flavor Cart, Stainless Steel Side Panels
620053990	Viper Elite 3 Flavor Cart, Stainless Steel Side Panels
620046556	Viper Elite 4 Flavor Cart, Stainless Steel Side Panels

TECHNICAL SPECIFICATIONS

SHIPPING WEIGHT 620043075: 175 lb (79.3 kg)
 620053990: 175 lb (79.3 kg)
 620046556: 200 lb (90.7 kg)

