



CONTINUOUS FLOW ICE MAKER

WCC700 - Series Illustrated Parts List

Release Date: February 07, 2018

Publication Number: 548000048

Revised Date: February 4, 2020

Revision: C

Visit the Cornelius web site at <http://ice.cornelius.com> for all your Literature needs.

Notice

The products, technical information, and instructions contained in this manual are subject to change without notice. These instructions are not intended to cover all details or variations of the equipment, nor to provide for every possible contingency in the installation, operation or maintenance of this equipment. This manual assumes that the person(s) working on the equipment have been trained and are skilled in working with electrical, plumbing, pneumatic, and mechanical equipment. It is assumed that appropriate safety precautions are taken and that all local safety and construction requirements are being met, in addition to the information contained in this manual.

This Product is warranted only as provided in Cornelius' Commercial Warranty applicable to this Product and is subject to all of the restrictions and limitations contained in the Commercial Warranty.

Cornelius will not be responsible for any repair, replacement or other service required by or loss or damage resulting from any of the following occurrences, including but not limited to, (1) other than normal and proper use and normal service conditions with respect to the Product, (2) improper voltage, (3) inadequate wiring, (4) abuse, (5) accident, (6) alteration, (7) misuse, (8) neglect, (9) unauthorized repair or the failure to utilize suitably qualified and trained persons to perform service and/or repair of the Product, (10) improper cleaning, (11) failure to follow installation, operating, cleaning or maintenance instructions, (12) use of "non-authorized" parts (i.e., parts that are not 100% compatible with the Product) which use voids the entire warranty, (13) Product parts in contact with water or the product dispensed which are adversely impacted by changes in liquid scale or chemical composition.

Correct Disposal of this Product



RECYCLE:

This marking indicates that this product should not be disposed with other household wastes throughout the EU. To prevent possible harm to the environment or human health from uncontrolled waste disposal, recycle it responsibly to promote the sustainable reuse of material resources. To return your used device, please use the return and collection systems or contact the retailer where the product was purchased. They can take this product for environmental safe recycling.

Trademarks and Copyrights

This document contains proprietary information and it may not be reproduced in any way without permission from Cornelius. This document contains the original instructions for the unit described.

CORNELIUS INC
101 Regency Drive
Glendale Heights, IL
Tel: + 1 800-238-3600

Printed in U.S.

Contact Information

To inquire about current revisions of any documentation or assistance with any Cornelius product, contact:

www.cornelius.com
800-238-3600



TABLE OF CONTENTS

CLADDINGS MODEL 700A SERIES1
 REFRIGERATION AND ICEMAKER ASSEMBLY MODEL 700A SERIES2
 HARDWARE MODEL 700A SERIES3
 CLADDINGS MODEL 700W SERIES4
 REFRIGERATION AND ICEMAKER ASSEMBLY MODEL 700W SERIES5
 HARDWARE MODEL 700W SERIES6
 CLADDINGS MODEL 700R SERIES7
 REFRIGERATION AND ICEMAKER ASSEMBLY MODEL 700R SERIES8
 HARDWARE MODEL 700R SERIES9
 CLADDINGS MODEL 700R CARBON SERIES10
 REFRIGERATION AND ICEMAKER ASSEMBLY MODEL 700R CARBON SERIES11
 HARDWARE MODEL 700R CARBON SERIES12
 CLADDINGS MODEL 700A CARBON SERIES13
 REFRIGERATION AND ICEMAKER ASSEMBLY MODEL 700A CARBON SERIES14
 HARDWARE MODEL 700A CARBON SERIES15
 CLADDINGS MODEL 700W CARBON SERIES16
 REFRIGERATION AND ICEMAKER ASSEMBLY MODEL 700W CARBON SERIES17
 HARDWARE MODEL 700W CARBON SERIES18
 WATER FLOAT ASSEMBLY 62005423119
 FRONT END ASSEMBLY MODEL 700 SERIES CHUNKLETS AND FLAKERS20
 ELECTRICAL BOX ASSEMBLY MODEL 700 SERIES21
 WCU 600 REMOTE CONDENSER22
 WCU 600 REMOTE CONDENSER23



CLADDINGS MODEL 700A SERIES

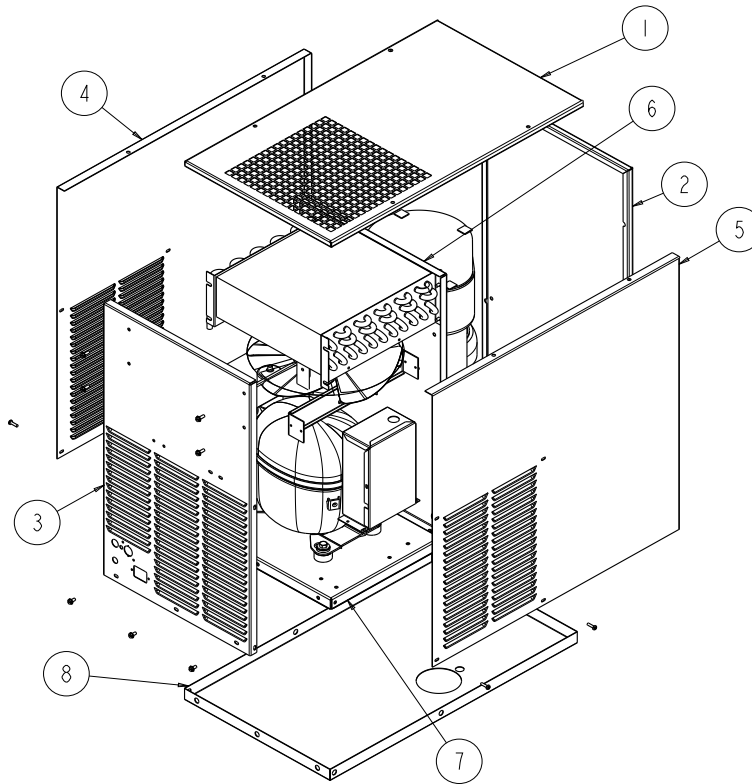

Figure 1

Item	Part No.	Description
1	638036254-01	PANEL TOP
2	638036265-01	PANEL FRONT
3	620054226	PANEL REAR
4	620054237	PANEL RH

5	620054238	PANEL LH
6	638008812	PANEL CENTER
7	620068377	PANEL BASE
8	620068378	COVER BASE

REFRIGERATION AND ICEMAKER ASSEMBLY MODEL 700A SERIES

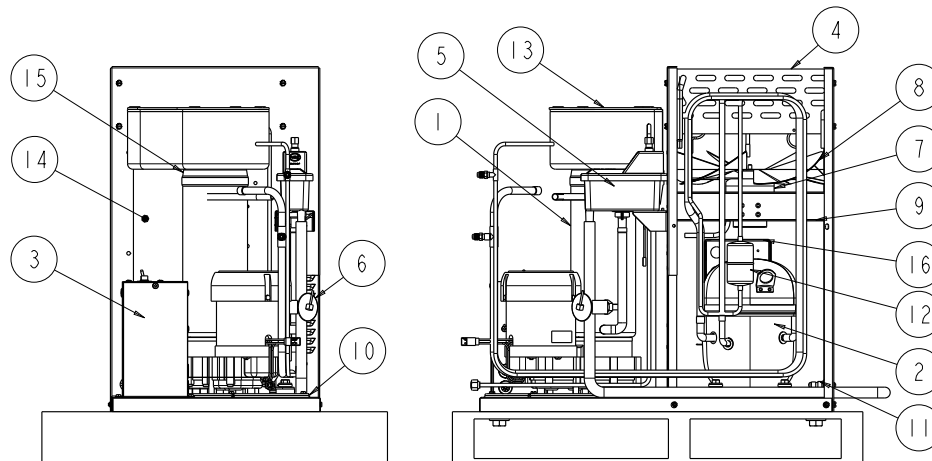

Figure 2.















Item	Part No.	Description
1A	620054225 Ref Page No 20	EVAP ASSY WCC 700
1B	620054230 Ref Page No 20	AUGER ASSY
2	638090221	COMPRESSOR, 115V (FOR UNIT WITH S/N'S STARTING WITH 62A AND 62B)
	638090241	COMPRESSOR 208/230V
	620054119	COMPRESSOR 115V RST64 (FOR UNIT WITH S/N'S STARTING WITH 62C)
	620068241	COMP COPELAND 404A RST70 (FOR UNIT WITH S/N'S STARTING WITH 62E)
3	620054229	ELECTRICAL BOX ASSEMBLY
4	638036273	CONDENSER-AIR COOL
5	620054231 Ref Page No 19	WATER LEVEL CONTROL ASSEMBLY
6	620068259	VALVE THERMAL EXPANSION
7	638090234	FAN MOTOR ASSEMBLY, 208/230V
	620067555	FAN MOTOR ASSEMBLY, 115V (FOR UNIT WITH S/N'S STARTING WITH 62E)
8	638096723	FAN BLADE
9	638008814	BRACKET, FAN MOTOR
10	638036218	BRACKET, MOUNTING ICEMAKER
11	638008409	BULKHEAD FITTING
12	620054241	DRYER ASSEMBLY
12A	638004393	DRYER
13	630900942	COVER, DISPENSE TRAY
13A	638036867-001	CLIP COVER
14	638036213	DROP TUBE ASSEMBLY
15	638036087	CLAMP, DISPENSE TRAY
16	620068308	COMP E-BOX
17*	7231762	GASKET FOAM 3/4X1 - QTY 13.2 IN
18*	638007206-04	NUT, JAM 1/2-20
19*	20654	ACCESS PORT

20*	23988	REPLACEMENT CAP
21*	630900953	THERMOSTAT WELL
22*	161998009	RELAY START 115V RST 64
	620054242	RELAY START 115V RST 64 (FOR UNIT WITH S/N'S STARTING WITH 62C)
23*	620068304	COMP START RELAY RST70 (FOR UNIT WITH S/N'S STARTING WITH 62E)
	638090242	RELAY START 208/230V, 60HZ
24*	161192004	CAPACITOR RUN 115V (FOR UNIT WITH S/N'S STARTING WITH 62A AND 62B)
	620054254	CAPACITOR RUN 115V RST64 (FOR UNIT WITH S/N'S STARTING WITH 62C)
	620068305	COMP RUN CAPACITOR RST70 (FOR UNIT WITH S/N'S STARTING WITH 62E)
25*	638090123	CAPACITOR RUN 208/230V, 60HZ RST64
26*	161165008	CAPACITOR START 115V
	620054243	CAPACITOR RUN 115V RST64 (FOR UNIT WITH S/N'S STARTING WITH 62C)
	620068306	COMP STARTING CAPACITOR RST70 (FOR UNIT WITH S/N'S STARTING WITH 62E)
27*	638090235	CONDENSER SHROUD
28*	629097851	KIT COMP REPLACEMENT WCC700A
29*	629097679	KIT ICE CHUTE INSTALLATION
30*	620054224	GROMMET COMPRESSOR RST64
31*	620054255	SLEEVE COMP RST64 WCC700A ICE MAKER
32*	620068902-002	HARN RST70 COMP E-BOX TO COMP
33*	620068310-002	HARN RST70 COMP E-BOX TO E-BOX

NOTE: * = Not Shown

HARDWARE MODEL 700A SERIES

Item	Part No.	Description	Images
1	164005001	RIVET POP 125D 065-125 SS	
2	620709629	CLIP STRAPPING 1/2" FOR PLSTC	
3	70070	WASHER FT-A031-0375-0875-070-ST	
4	168833002	WASHER EXTL-A#08-0176-0381-023-S	
5	638007052-02	SCREW HEX 10-32 X 0.5L 16STZI	
6	00258	NUT SPED 1/4-20 ST FS	
7	03612	SCREW HEX 8-36 X 0.5L 16STZI	
8	07516	WASHER FT-A#08-0188-0375-045-S2	
9	161168012	SCREW TC 08-32 X 0.25L HXWS 08 ST GRN	
10	638007276-01	NUT 10A OR Z TINN FL FS	
11	03535	SCREW SM 10 X 0.25L TB PHSL 08 STZI	
12	168770002	BOLT HEX MA 5/16-18 X 1.5L 48 STZI	

13	638007098-04	BOLT HEX MA 1/2-13 X 1.5L 40 STZI	
14	638007301-07	WASHER FT-A050-0531-1250-100-ST	
15	638007972-02	SCREW 10 X 0.5L TYPE B HHWF FS	
16	164083001	NUT HEX 06-32 STZI LOCK FS	
17	164083004	NUT HEX 08-32 STZI LOCK	
18	630900111	SCREW TC 08-32 X 0.75L PAPH 24 ST ZC	
19	638007002-03	SCREW MA 06-32 X 0.375L PAPH 12 FS	
20	161168005	SCREW HEX TC 08-32 X 0.5L 16 STZI GR	
21	164713001	SCREW TC 08-32 X 0.375L TRPH 12 SS FS	
22	638007026-09	SCREW 8-32 X 0.75L BHMS FS	
23	638007262-01	NUT TINNEMAN TYPE J	
24	638007972-01	SCREW #10 X 0.375L B TYPE HHWF	

CLADDINGS MODEL 700W SERIES

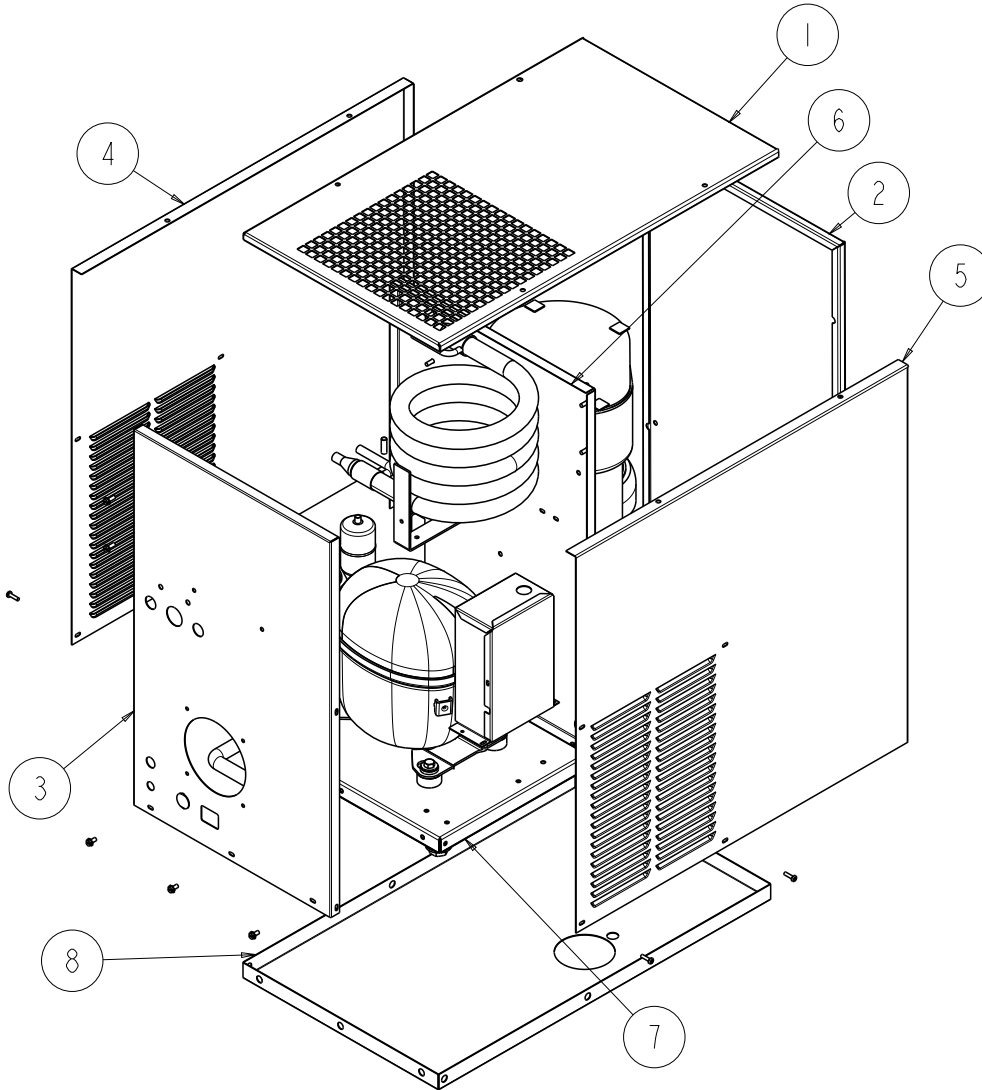

Figure 3

Item	Part No.	Description
1	638036254-01	PANEL TOP
2	638036265-01	PANEL FRONT
3	620057411	PANEL REAR
4	620054237	PANEL RH
5	620054238	PANEL LH
6	638008812	PANEL CENTER
7	620068377	PANEL BASE
8	620068378	COVER BASE

REFRIGERATION AND ICEMAKER ASSEMBLY MODEL 700W SERIES

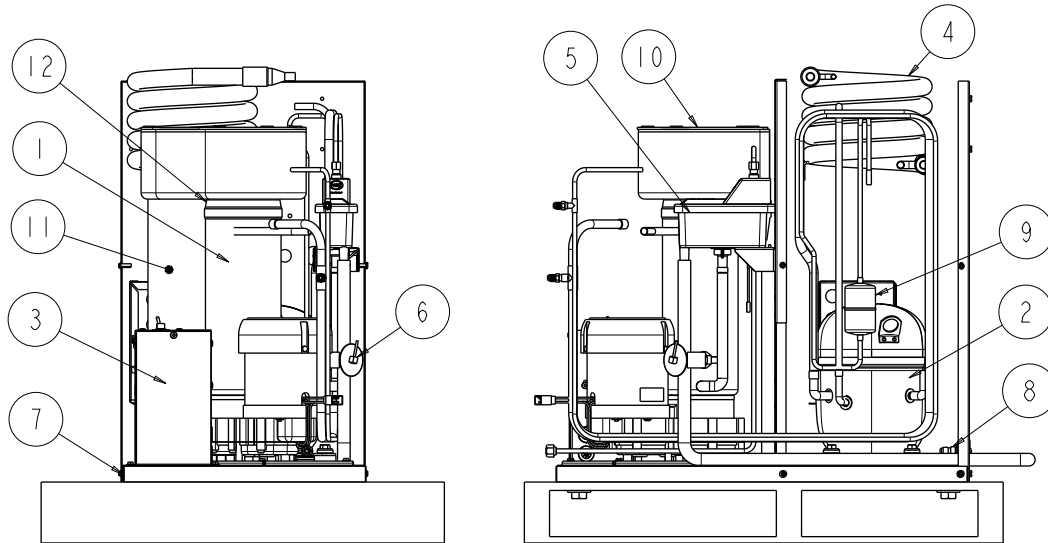

Figure 4.



Item No.	Part No.	Description
1A	620054225 Ref Page No 20	EVAP ASSY WCC 700
1B	620054230 Ref Page No 20	AUGER ASSY
2	638090221	COMPRESSOR, 115V (FOR UNIT WITH S/N'S STARTING WITH 62A AND 62B)
	638090241	COMPRESSOR 208/230V
	620054119	COMPRESSOR 115V RST64 (FOR UNIT WITH S/N'S STARTING WITH 62C)
3	630000880	ELECTRICAL BOX ASSEMBLY
4	630901139	CONDENSER COIL
5	620054231 Ref Page No 19	WATER LEVEL CONTROL ASSEMBLY
6	620068259	VALVE THERMAL EXPANSION
7	638036218	BRACKET, MOUNTING ICE-MAKER
8	638008409	BULKHEAD FITTING
9	620054241	DRYER ASSEMBLY
9A	638004393	DRYER
10	630900942	COVER, DISPENSE TRAY
10A	638036867-001	CLIP COVER
11	638036213	DROP TUBE ASSEMBLY
12	638036269	CLAMP, DISPENSE TRAY
13*	638007206-04	NUT, JAM 1/2-20

14*	7231762	GASKET FOAM 3/4X1 - QTY 13.2 IN
15*	20654	ACCESS PORT
16*	23988	REPLACEMENT CAP
17*	630900953	THERMOSTAT WELL
18*	638007208-03	NUT, PALNUT, 3/4-16
19*	630201362	BRACKET, MOUNTING CONDENSER
20*	638009755	PRESSURE SWITCH
21*	620055903	WATER REGULATING VALVE
	161998009	RELAY START 115V RST 64
22*	620054242	RELAY START 115V RST 64 FOR UNIT WITH S/N'S STARTING WITH 62C
	638090242	RELAY START 208/230V, 60HZ
24*	161192004	CAPACITOR RUN 115V (FOR UNIT WITH S/N'S STARTING WITH 62A AND 62B)
	620054254	CAPACITOR RUN 115V RST64 (FOR UNIT WITH S/N'S STARTING WITH 62C)
25*	638090123	CAPACITOR RUN 208/230V, 60HZ
26*	161165008	CAPACITOR START 115V
	620054243	CAPACITOR RUN 115V RST64 (FOR UNIT WITH S/N'S STARTING WITH 62C)
27*	25335	CAPACITOR START 208/230V, 60HZ
28*	629097159	KIT COMP REPLACEMENT WCC700-W

* = Not Shown

HARDWARE MODEL 700W SERIES

Item	Part No.	Description	Images
1	620709629	CLIP STRAPPING 1/2" FOR PLSTC	
2	70070	WASHER FT-A031-0375-0875-070-ST	
3	638007052-02	SCREW HEX 10-32 X 0.5L 16STZI	
4	168770002	BOLT HEX MA 5/16-18 X 1.5L 48 STZI	
5	07115001	SCREW TF 08-32 X 0.375L TRPH 12 SS	
6	161168000	SCREW MA 08-32 X 0.25L TRPH 08 SS	
7	161168006	SCREW HEX TC 08-32 X 0.375L 12 SSBL	
8	161168015	SCREW GRN 10-32 X 0.375L TYPE F	

9	164083003	NUT HEX 1/4-20 X 0.2H STZI LOCK	
10	164510000	NUT-GROMMET SELF-TAP #8-#10 FS	
11	638007972-02	SCREW 10 X 0.5L TYPE B HHWF FS	
12	168745000	BOLT HEX MA 1/4-20 X 0.5L 16 STZI	
13	24056	WASHER EXTL-A025-0260-0500-025-S	
14	343417000	SCREW TC 10-32 X 0.375L PAPH 12 STZI 23	
15	560000389	SCREW MA 10-32 X 2L PAPH 64 STZI	
16	638007208-03	NUT PALNUT 3/4-16 X 0.225 THK	
17	70910	SCREW MA 10-32 X 1.25L TRPH 40 SS FS	

CLADDINGS MODEL 700R SERIES

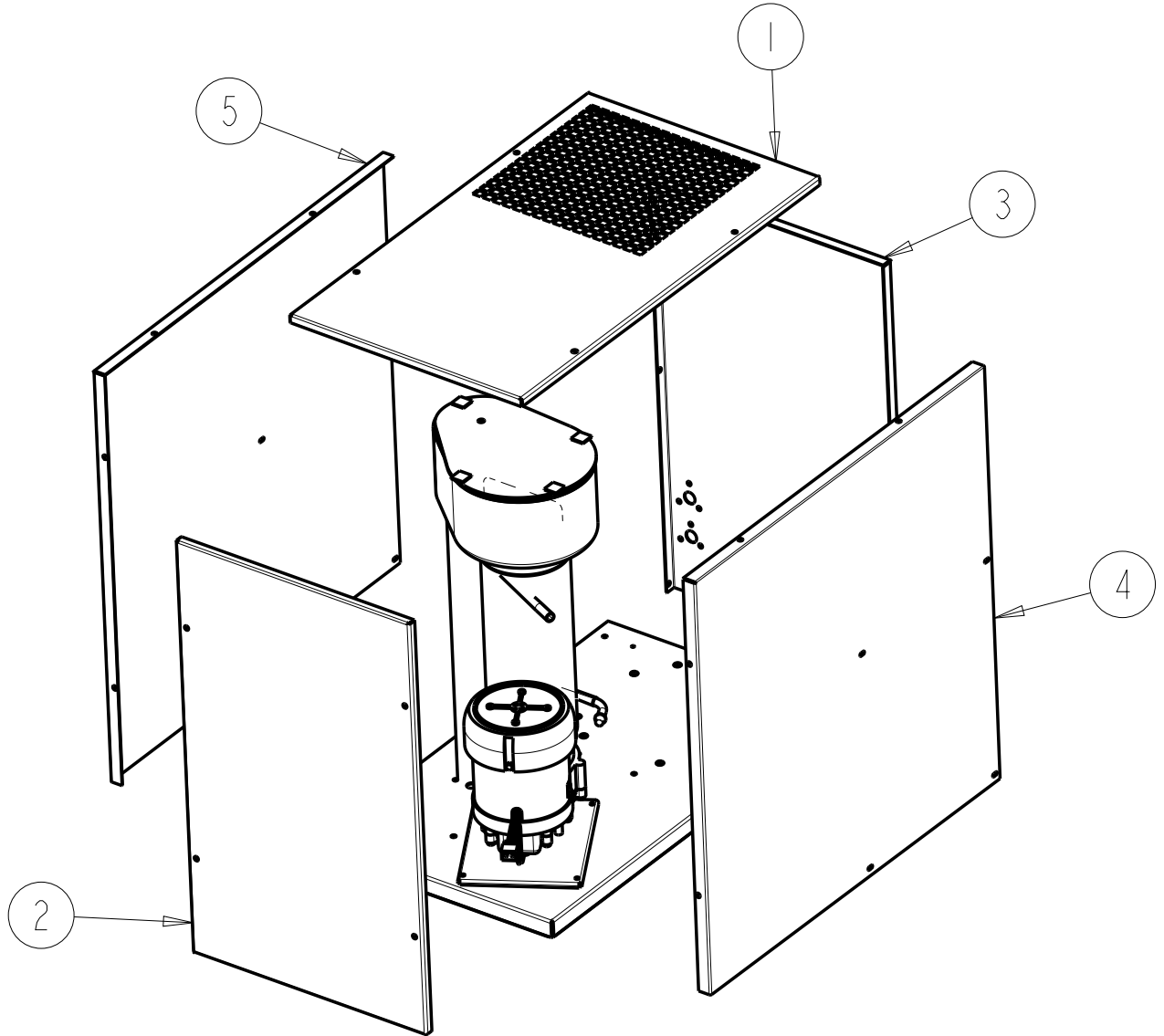

Figure 5

Item	Part No.	Description
1	638036254-01	PANEL TOP
2	638036265-01	PANEL FRONT
3	638036234	PANEL REAR
4	638036253-01	PANEL RH
5	638036252-01	PANEL LH
6	638036217	PANEL BASE

REFRIGERATION AND ICEMAKER ASSEMBLY MODEL 700R SERIES

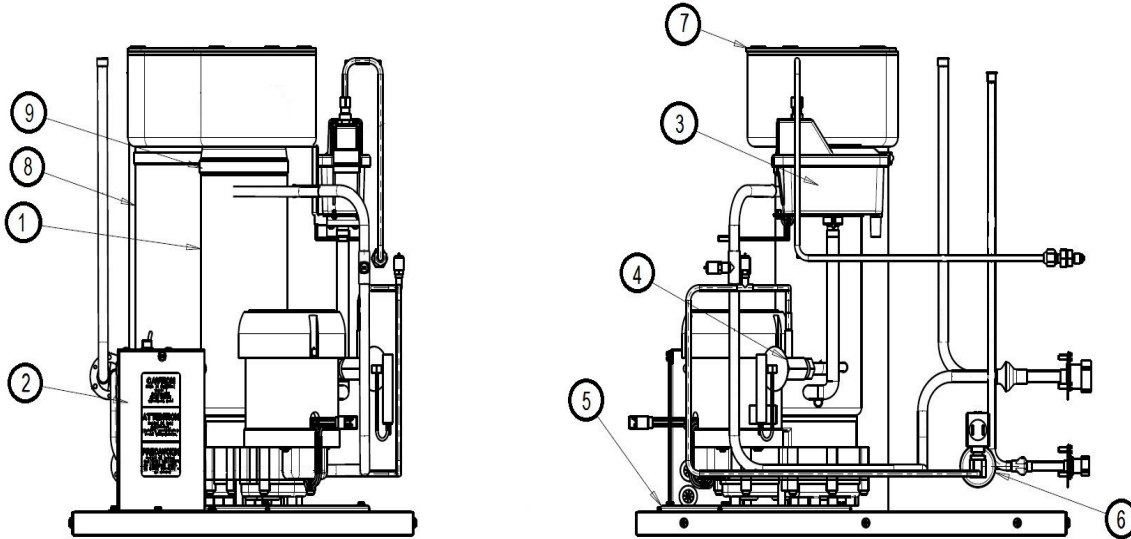

Figure 6.











Item No.	Part No.	Description
1A	620054225 Ref Page No 20	EVAP ASSY WCC 700
1B	620054230 Ref Page No 20	AUGER ASSY
2	638090246	ELECTRICAL BOX ASSEMBLY
3	620054231 Ref Page No 19	WATER LEVEL CONTROL ASSEMBLY
4	620068259	VALVE THERMAL EXPANSION
5	638036218	BRACKET, MOUNTING ICE-MAKER
6	620054241	DRYER ASSEMBLY
6A	638004393	DRYER
7	630900942	COVER, DISPENSE TRAY
7A	638036867-001	CLIP COVER
8	638036213	DROP TUBE ASSEMBLY
9	638036269	CLAMP, DISPENSE TRAY
10*	7231762	GASKET FOAM 3/4X1 - QTY 13.2 IN
11*	638007206-04	NUT, JAM 1/2-20
12*	20654	ACCESS PORT
13*	23988	REPLACEMENT CAP
14*	630900953	THERMOSTAT WELL
15*	638007208-03	NUT, PALNUT, 3/4-16
16*	638008834	BRACKET, MOUNTING CONDENSER
17*	638009755	PRESSURE SWITCH

18*	620055903	WATER REGULATING VALVE
19*	161998009	RELAY START 115V RST 64
	620054242	RELAY START 115V RST 64 FOR UNIT WITH S/N'S STARTING WITH 62C
20*	638090242	RELAY START 208/230V, 60HZ
21*	161192004	CAPACITOR RUN 115V (FOR UNIT WITH S/N'S STARTING WITH 62A AND 62B)
	620054254	CAPACITOR RUN 115V RST64 (FOR UNIT WITH S/N'S STARTING WITH 62C)
22*	638090123	CAPACITOR RUN 208/230V, 60HZ
23*	161165008	CAPACITOR START 115V
	620054243	CAPACITOR RUN 115V RST64 (FOR UNIT WITH S/N'S STARTING WITH 62C)
24*	25335	CAPACITOR START 208/230V, 60HZ
25*	638090221	COMPRESSOR, 115V (FOR UNIT WITH S/N'S STARTING WITH 62A AND 62B)
	638090241	COMPRESSOR 208/230V
	620054119	COMPRESSOR 115V RST64 (FOR UNIT WITH S/N'S STARTING WITH 62C)
26*	638008409	BULKHEAD FITTING

* = Not Shown

HARDWARE MODEL 700R SERIES

Item	Part No.	Description	Images
1	161168017	SCREW MA 06-32 X 0.25L PAPH 08 SS FS	
2	161179001	BOLT HEX MA 1/4-20 X 0.625L 20 SSPA	
3	168833000	WASHER SL-A025-0260-0487-062-S8	
4	168833002	WASHER EXTL-A#08-0176-0381-023-S	
5	638007052-02	SCREW HEX 10-32 X 0.5L 16STZI	
6	311462000	BOLT HEX MA 5/16-18 X 0.5L 16 STZI	
7	638007026-01	SCREW MA 08-32 X 0.375L PAPH 12 SS	
8	638007301-030	WASHER FT-A088-1000-2000-062-S8	
9	07578	SCREW TC 08-32 X 0.375L TRPH 12 STZC FS	
10	638007026-03	SCREW MA 08-32 X 0.625L PAPH 20 SS	

11	161168015	SCREW GRN GND 10-32 X 0.375L TYPE F	
12	638007098-04	BOLT HEX MA 1/2-13 X 1.5L 40 STZI	
13	638007301-07	WASHER FT-A050-0531-1250-100-ST	
14	638007972-02	SCREW 10 X 0.5L TYPE B HHWF FS	
15	164083001	NUT HEX 06-32 STZI LOCK FS	
16	164083004	NUT HEX 08-32 STZI LOCK	
17	638007002-03	SCREW MA 06-32 X 0.375L PAPH 12 FS	
18	164713001	SCREW TC 08-32 X 0.375L TRPH 12 SS FS	
19	638007026-09	SCREW 8-32 X 0.75L BHMS FS	
20	638007262-01	NUT TINNEMAN TYPE J	
21	638007972-01	SCREW #10 X 0.375L B TYPE HHWF	

CLADDINGS MODEL 700R CARBON SERIES

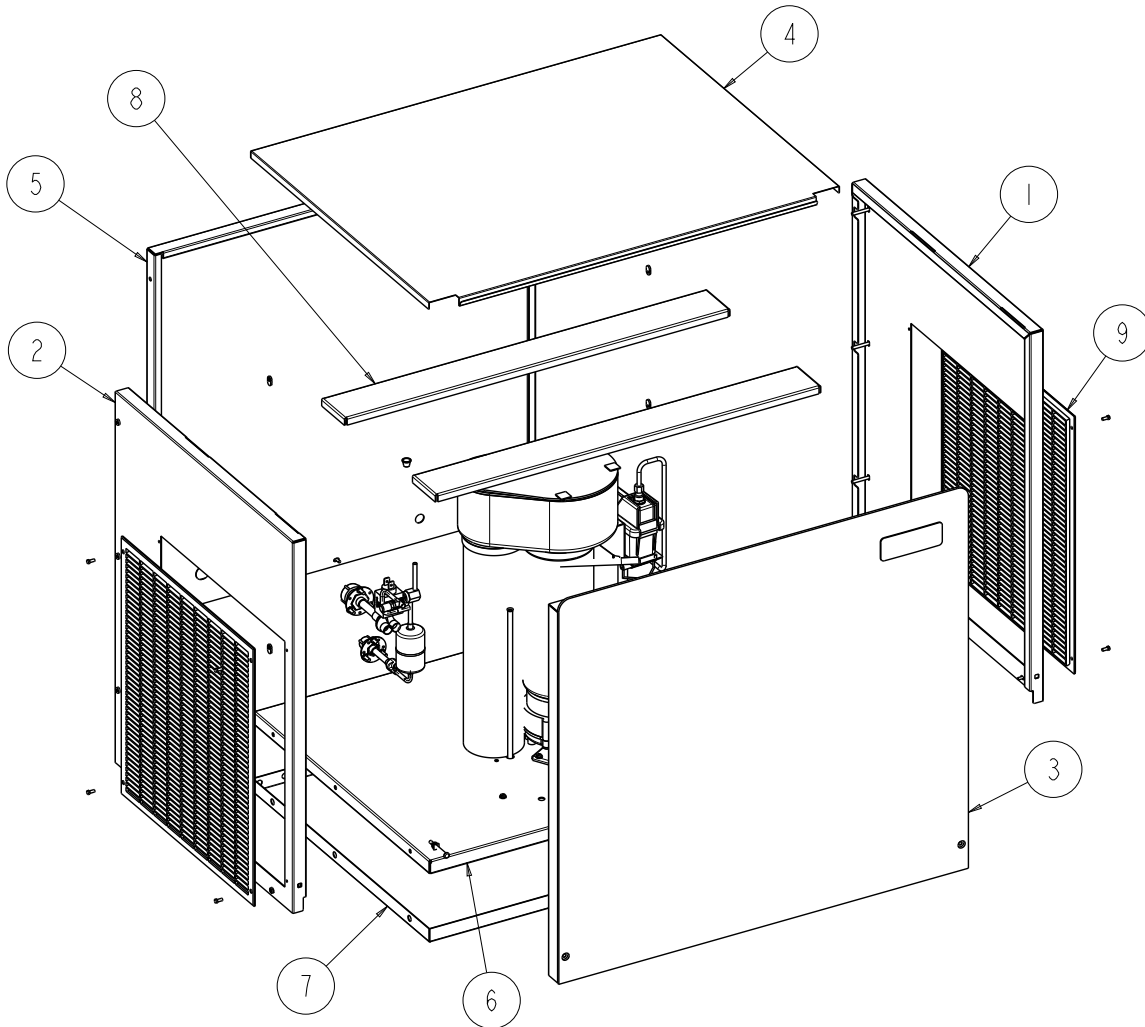

Figure 7

Item	Part No.	Description
1	620071451	PANEL RH (FOR UNIT WITH S/N'S STARTING WITH 62Q1930BG)
	620067251	PANEL RH
2	620071452	PANEL LH (FOR UNIT WITH S/N'S STARTING WITH 62Q1930BG)
	620067252	PANEL LH
3	620071177	PANEL FRONT (FOR UNIT WITH S/N'S STARTING WITH 62Q1930BG)
	620067039	PANEL FRONT
4	620067254	PANEL TOP
5	620071453	PANEL REAR (FOR UNIT WITH S/N'S STARTING WITH 62Q1930BG)
	620067253	PANEL REAR
6	620067179	PANEL BASE
7	620068724	COVER BASE
8	630201705	BRACE CABINET
9	166194001	GRILL PLASTIC

REFRIGERATION AND ICEMAKER ASSEMBLY MODEL 700R CARBON SERIES

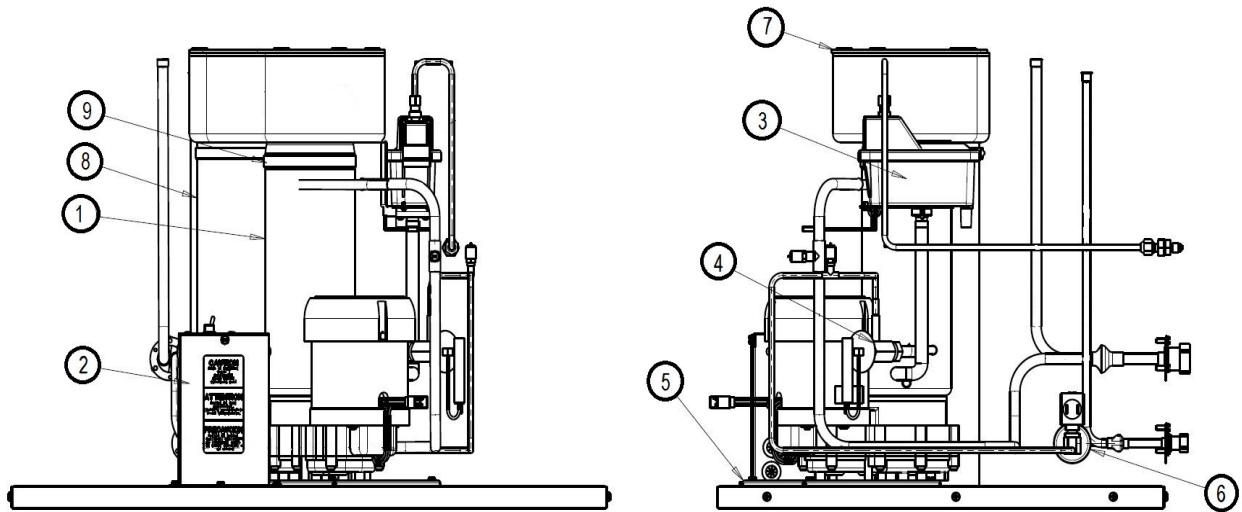













Figure 8.

Item No.	Part No.	Description
1A	620054225 Ref Page No 20	EVAP ASSY WCC 700
1B	620054230 Ref Page No 20	AUGER ASSY
2	638090246	ELECTRICAL BOX ASSEMBLY
3	620054231 Ref Page No 19	WATER LEVEL CONTROL ASSEMBLY
4	620068259	VALVE THERMAL EXPANSION
5	638036218	BRACKET, MOUNTING ICE-MAKER
6	620054241	DRYER ASSEMBLY
6A	638004393	DRYER
7	630900942	COVER, DISPENSE TRAY
7A	638036867-001	CLIP COVER
8	638036213	DROP TUBE ASSEMBLY
9	638036269	CLAMP, DISPENSE TRAY
10*	7231762	GASKET FOAM 3/4X1 - QTY 13.2 IN
11*	638007206-04	NUT, JAM 1/2-20
12*	20654	ACCESS PORT
13*	23988	REPLACEMENT CAP
14*	630900953	THERMOSTAT WELL
15*	638007208-03	NUT, PALNUT, 3/4-16
16*	638008834	BRACKET, MOUNTING CONDENSER
17*	638009755	PRESSURE SWITCH

18*	620055903	WATER REGULATING VALVE
19*	161998009	RELAY START 115V RST 64
	620054242	RELAY START 115V RST 64 FOR UNIT WITH S/N'S STARTING WITH 62C
20*	638090242	RELAY START 208/230V, 60HZ
21*	161192004	CAPACITOR RUN 115V (FOR UNIT WITH S/N'S STARTING WITH 62A AND 62B)
	620054254	CAPACITOR RUN 115V RST64 (FOR UNIT WITH S/N'S STARTING WITH 62C)
22*	638090123	CAPACITOR RUN 208/230V, 60HZ
23*	161165008	CAPACITOR START 115V
	620054243	CAPACITOR RUN 115V RST64 (FOR UNIT WITH S/N'S STARTING WITH 62C)
24*	25335	CAPACITOR START 208/230V, 60HZ
25*	638090221	COMPRESSOR, 115V (FOR UNIT WITH S/N'S STARTING WITH 62A AND 62B)
	638090241	COMPRESSOR 208/230V
	620054119	COMPRESSOR 115V RST64 (FOR UNIT WITH S/N'S STARTING WITH 62C)
26*	638008409	BULKHEAD FITTING

* = Not Shown

HARDWARE MODEL 700R CARBON SERIES

1	161168017	SCREW MA 06-32 X 0.25L PAPH 08 SS FS	
2	161168006	SCREW HEX TC 08-32 X 0.375L 12 SSBL	
3	164510000	NUT- GROMMET SELF-TAP#8-#10 FS	
4	343417000	SCREW TC 10-32 X 0.375L PAPH 12 STZI 23	
5	560000389	SCREW MA 10-32 X 2L PAPH 64 STZI	
6	620701903	WASHER FT-A#08-0177-0408-062-NY	
7	638007972-03	SCREW #10 X 0.75 L TYPE B HHWFFS	
8	07578	SCREW TC 08-32 X 0.375L TRPH 12 STZC FS	
9	161168015	SCREW GRN GND 10-32 X 0.375L TYPE F	
10	638007972-02	SCREW 10 X 0.5L TYPE B HHWF FS	
11	638007002-03	SCREW MA 06-32 X 0.375L PAPH 12 FS	
12	638007972-01	SCREW #10 X 0.375L B TYPE HHWF	

CLADDINGS MODEL 700A CARBON SERIES

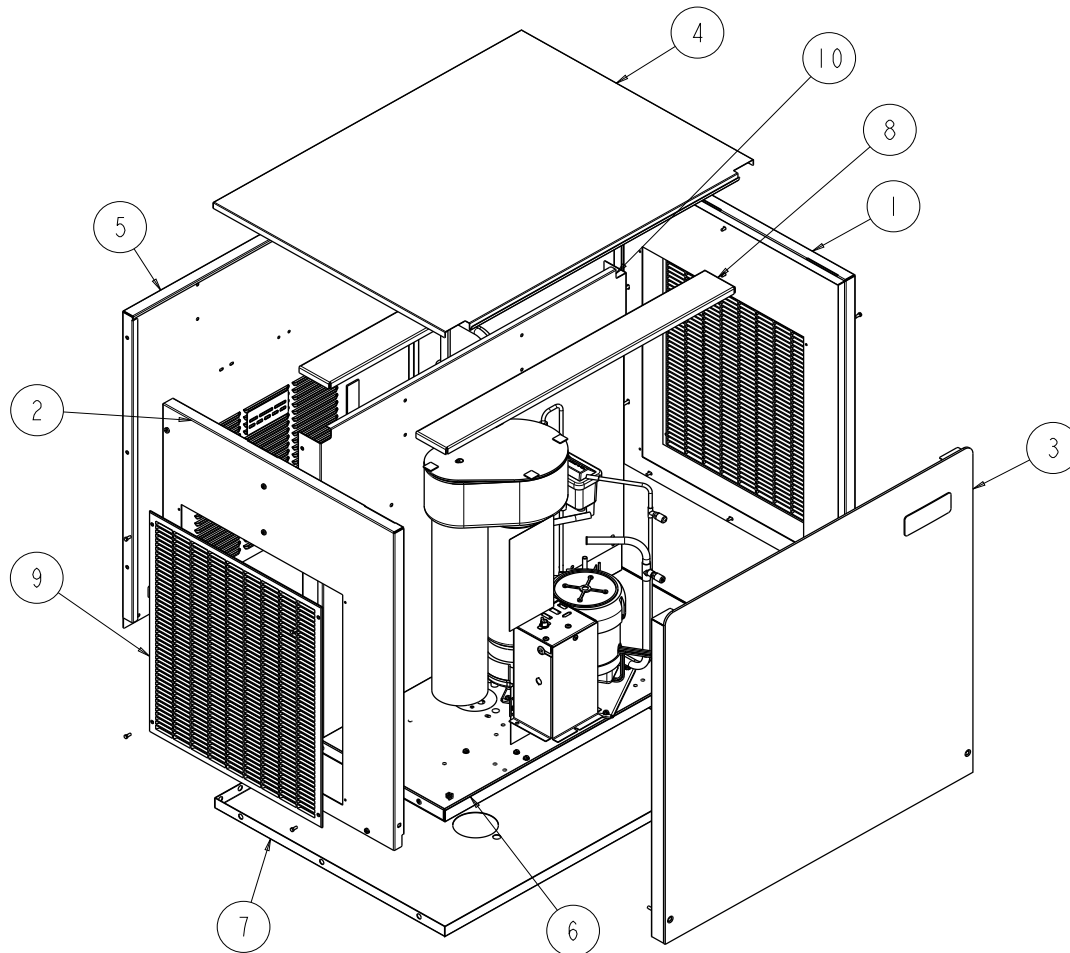

Figure 9

Item	Part No.	Description
1	620067734	PANEL RH
	620071180	PANEL RH (FOR UNIT WITH S/N'S STARTING WITH 62R1914BG)
2	620067735	PANEL LH
	620071184	PANEL LH (FOR UNIT WITH S/N'S STARTING WITH 62R1914BG)
3	620067039	PANEL FRONT
	620071179	PANEL FRONT (FOR UNIT WITH S/N'S STARTING WITH 62R1914BG)
4	620068211	PANEL TOP
5	620068216	PANEL REAR
	620071183	PANEL REAR (FOR UNIT WITH S/N'S STARTING WITH 62R1914BG)
6	620068208	PANEL BASE
7	620068231	COVER BASE
8	630201705	BRACE CABINET
9	166194001	GRILL PLASTIC
10	620068212	PANEL CENTER
	620071182	PANEL CENTER (FOR UNIT WITH S/N'S STARTING WITH 62R1914BG)

REFRIGERATION AND ICEMAKER ASSEMBLY MODEL 700A CARBON SERIES

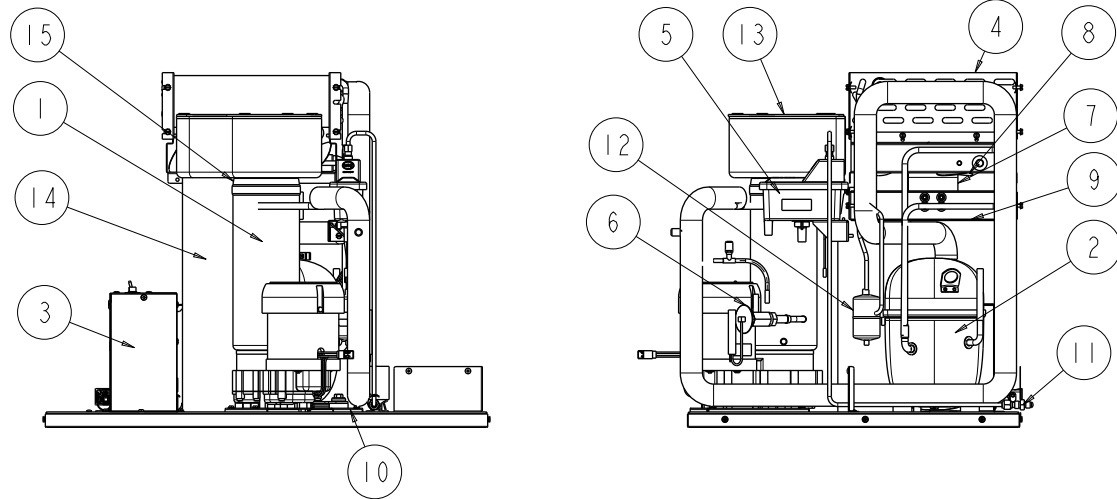

Figure 10.

Item	Part No.	Description
1A	620054225 Ref Page No 20	EVAP ASSY WCC 700
1B	620054230 Ref Page No 20	AUGER ASSY
2	620054119	COMPRESSOR 115V RST64 (FOR UNIT WITH S/N'S START- ING WITH 62C)
	620068241	COMP COPELAND 404A RST70 (FOR UNIT WITH S/N'S START- ING WITH 62R1906BG)
3	620054229	ELECTRICAL BOX ASSEMBLY
4	638036273	CONDENSER-AIR COOL
5	620054231 Ref Page No 19	WATER LEVEL CONTROL ASSEMBLY
6	620068259	VALVE THERMAL EXPANSION
7	620067555	FAN MOTOR ASSEMBLY, 115V (FOR UNIT WITH S/N'S START- ING WITH 62R1906BG)
8	638096723	FAN BLADE
9	638008814	BRACKET, FAN MOTOR
10	638036218	BRACKET, MOUNTING ICE- MAKER
11	638008409	BULKHEAD FITTING
12	620054241	DRYER ASSEMBLY
12A	638004393	DRYER
13	630900942	COVER, DISPENSE TRAY
13A	638036867- 001	CLIP COVER
14	638036213	DROP TUBE ASSEMBLY
15	638036087	CLAMP, DISPENSE TRAY
16	620068308	COMP E-BOX
17*	960115000	INSULATION TAPE 1/8 X 1/2" X 50' ROLL
18*	638007206-04	NUT, JAM 1/2-20
19*	20654	ACCESS PORT

20*	23988	REPLACEMENT CAP
21*	630900953	THERMOSTAT WELL
22*	620054242	RELAY START 115V RST 64 (FOR UNIT WITH S/N'S START- ING WITH 62C)
	620068304	COMP START RELAY RST70 (FOR UNIT WITH S/N'S START- ING WITH 62E)
23*	620054254	CAPACITOR RUN 115V RST64 (FOR UNIT WITH S/N'S START- ING WITH 62C)
	620068305	COMP RUN CAPACITOR RST70 (FOR UNIT WITH S/N'S START- ING WITH 62R1906BG)
24*	638090123	CAPACITOR RUN 208/230V, 60HZ RST64
25*	620054243	CAPACITOR RUN 115V RST64 (FOR UNIT WITH S/N'S START- ING WITH 62C)
	620068306	COMP STARTING CAPACITOR RST70 (FOR UNIT WITH S/N'S STARTING WITH 62R1906BG)
26*	638090235	CONDENSER SHROUD
27*	629097851	KIT COMP REPLACEMENT WCC700A
28*	629097679	KIT ICE CHUTE INSTALLATION
29*	620054224	GROMMET COMPRESSOR RST64
30*	620054255	SLEEVE COMP RST64 WCC700A ICE MAKER
31*	620068902- 002	HARN RST70 COMP E-BOX TO COMP
32*	620068310- 002	HARN RST70 COMP E-BOX TO E- BOX

* = Not Shown

HARDWARE MODEL 700A CARBON SERIES

Item	Part No.	Description	Images
1	70070	WASHER FT-A031-0375-0875-070-ST	
2	07115001	SCREW TF 08-32 X 0.375L TRPH 12 SS	
3	07153	WASHER FT-A038-0406-1250-060-ST	
4	00258	NUT SPED 1/4-20 ST FS	
5	03612	SCREW HEX 8-36 X 0.5L 16STZI	
6	07516	WASHER FT-A#08-0188-0375-045-S2	
7	161168006	SCREW HEX TC 08-32 X 0.375L 12 SSBL	
8	638007276-01	NUT 10A OR Z TINN FL FS	
9	03535	SCREW SM 10 X 0.25L TB PHSL 08 STZI	
10	168770002	BOLT HEX MA 5/16-18 X 1.5L 48 STZI	
11	164510000	NUT- GROMMET SELF-TAP#8-#10 FS	
12	343417000	SCREW TC 10-32 X 0.375L PAPH 12 STZI 23	
13	638007972-02	SCREW 10 X 0.5L TYPE B HHWF FS	
14	560000389	SCREW MA 10-32 X 2L PAPH 64 STZI	
15	70910	SCREW MA 10-32 X 1.25L TRPH 40 SS FS	
16	638007026-01	SCREW MA 08-32 X 0.375L PAPH 12 SS	
17	161168015	SCREW GRN GND 10-32 X 0.375L TYPE F	
18	638007262-01	NUT TINNERMAN TYPE J	

CLADDINGS MODEL 700W CARBON SERIES

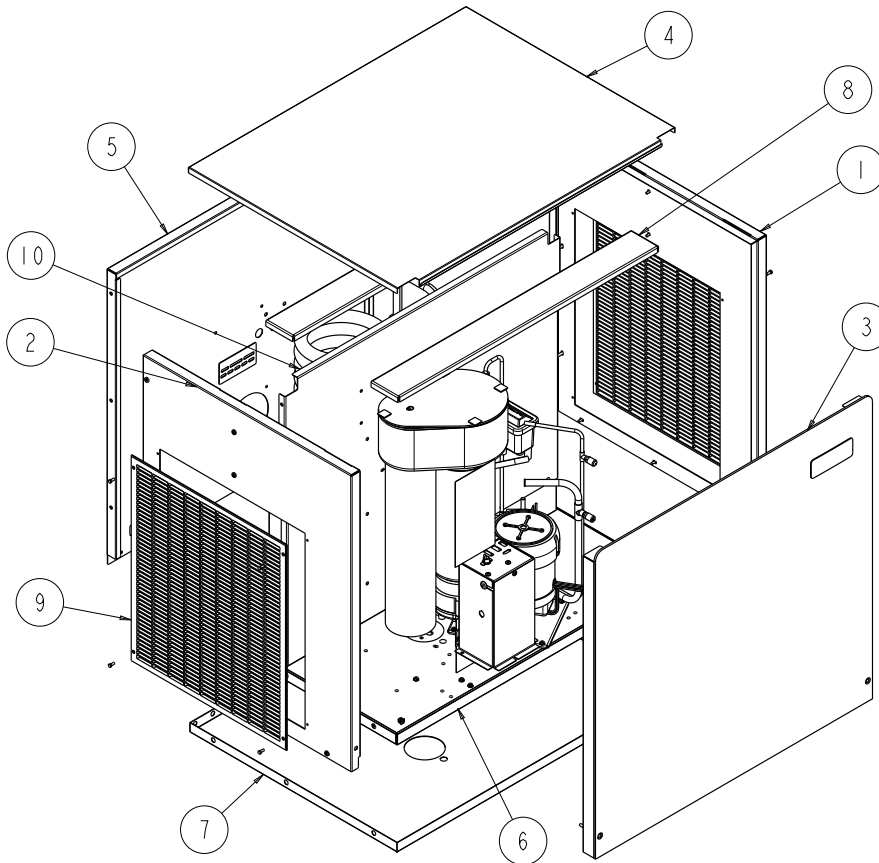

Figure 11

Item	Part No.	Description
1	620071180	PANEL RH (FOR UNIT WITH S/N'S STARTING WITH 62R1924BG)
	620067734	PANEL RH
2	620071184	PANEL LH (FOR UNIT WITH S/N'S STARTING WITH 62R1924BG)
	620067735	PANEL LH
3	620071177	PANEL FRONT (FOR UNIT WITH S/N'S STARTING WITH 62R1924BG)
	620067039	PANEL FRONT
4	620067254	PANEL TOP
5	620071477	PANEL REAR (FOR UNIT WITH S/N'S STARTING WITH 62R1924BG)
	620067714	PANEL REAR
6	620067715	PANEL BASE
7	620068723	COVER BOTTOM
8	630201705	BRACE CABINET
9	166194001	GRILL PLASTIC
10	620071478	PANEL CENTER (FOR UNIT WITH S/N'S STARTING WITH 62R1924BG)
	620067712	PANEL CENTER

REFRIGERATION AND ICEMAKER ASSEMBLY MODEL 700W CARBON SERIES

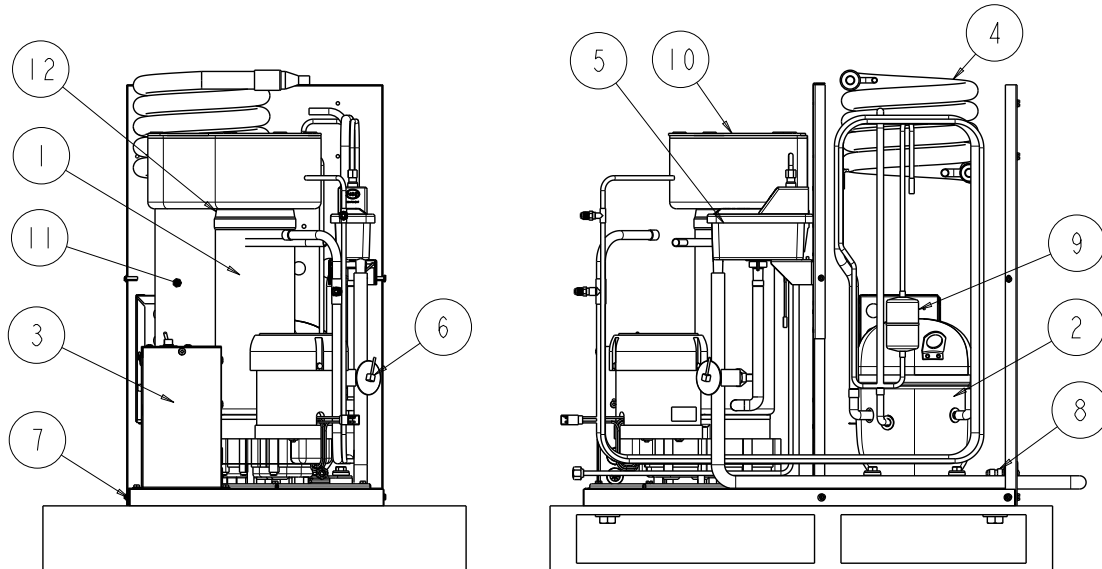

Figure 12.

Item No.	Part No.	Description
1A	620054225 Ref Page No 20	EVAP ASSY WCC 700
1B	620054230 Ref Page No 20	AUGER ASSY
2	638090221	COMPRESSOR, 115V (FOR UNIT WITH S/N'S STARTING WITH 62A AND 62B)
	638090241	COMPRESSOR 208/230V
	620054119	COMPRESSOR 115V RST64 (FOR UNIT WITH S/N'S STARTING WITH 62C)
3	630000880	ELECTRICAL BOX ASSEMBLY
4	630901139	CONDENSER COIL
5	620054231 Ref Page No 19	WATER LEVEL CONTROL ASSEMBLY
6	620068259	VALVE THERMAL EXPANSION
7	638036218	BRACKET, MOUNTING ICE-MAKER
8	638008409	BULKHEAD FITTING
9	620054241	DRYER ASSEMBLY
9A	638004393	DRYER
10	630900942	COVER, DISPENSE TRAY
10A	638036867-001	CLIP COVER
11	638036213	DROP TUBE ASSEMBLY
12	638036269	CLAMP, DISPENSE TRAY
13*	638007206-04	NUT, JAM 1/2-20
14*	7231762	GASKET FOAM 3/4X1 - QTY 13.2 IN

15*	20654	ACCESS PORT
16*	23988	REPLACEMENT CAP
17*	630900953	THERMOSTAT WELL
18*	638007208-03	NUT, PALNUT, 3/4-16
19*	630201362	BRACKET, MOUNTING CONDENSER
20*	638009755	PRESSURE SWITCH
21*	620055903	WATER REGULATING VALVE
22*	161998009	RELAY START 115V RST 64
	620054242	RELAY START 115V RST 64 FOR UNIT WITH S/N'S STARTING WITH 62C
23*	638090242	RELAY START 208/230V, 60HZ
24*	161192004	CAPACITOR RUN 115V (FOR UNIT WITH S/N'S STARTING WITH 62A AND 62B)
	620054254	CAPACITOR RUN 115V RST64 (FOR UNIT WITH S/N'S STARTING WITH 62C)
25*	638090123	CAPACITOR RUN 208/230V, 60HZ
26*	161165008	CAPACITOR START 115V
	620054243	CAPACITOR RUN 115V RST64 (FOR UNIT WITH S/N'S STARTING WITH 62C)
27*	25335	CAPACITOR START 208/230V, 60HZ
28*	629097159	KIT COMP REPLACEMENT WCC700-W

* = Not Shown

HARDWARE MODEL 700W CARBON SERIES

1	70070	WASHER FT-A031-0375-0875-070-ST	
2	07115001	SCREW TF 08-32 X 0.375L TRPH 12 SS	
3	161168000	SCREW MA 08-32 X 0.25L TRPH 08 SS	
4	164083003	NUT HEX 1/4-20 X 0.2H STZI LOCK	
5	168745000	BOLT HEX MA 1/4-20 X 0.5L 16 STZI	
6	24056	WASHER EXTL-A025-0260-0500-025-S	
7	161168006	SCREW HEX TC 08-32 X 0.375L 12 SSBL	
8	638007052-02	SCREW HEX 10-32 X 0.5 L 16STZI	

9	168770002	BOLT HEX MA 5/16-18 X 1.5L 48 STZI	
10	164510000	NUT- GROMMET SELF-TAP#8-#10 FS	
11	343417000	SCREW TC 10-32 X 0.375L PAPH 12 STZI 23	
12	638007972-02	SCREW 10 X 0.5L TYPE B HHWF FS	
13	560000389	SCREW MA 10-32 X 2L PAPH 64 STZI	
14	70910	SCREW MA 10-32 X 1.25L TRPH 40 SS FS	
15	161168015	SCREW GRN GND 10-32 X 0.375L TYPE F	

WATER FLOAT ASSEMBLY 620054231

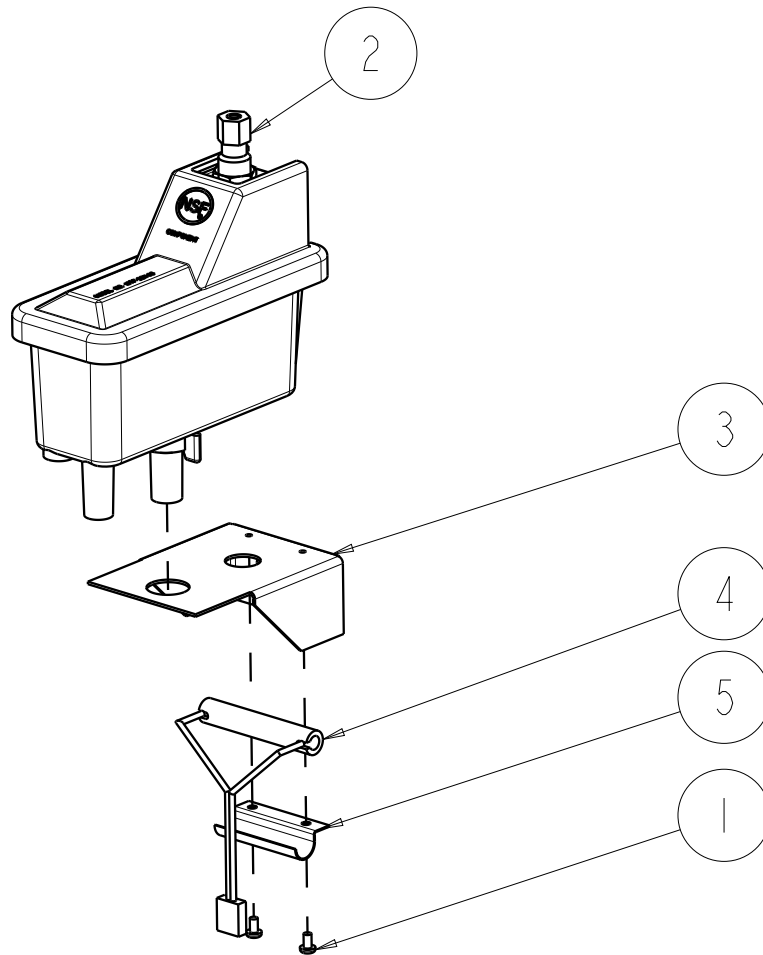

Figure 13

Item	Part No.	Description
1	161168017	SCREW #6-32
2	630900547	WATER LEVEL CONTROL ASSEMBLY
3	638004717	BRKT WATER LEVEL
4	638008483	REED SWITCH ASSEMBLY
5	638008097	CLAMP REED SWITCH

FRONT END ASSEMBLY MODEL 700 SERIES CHUNKLETS AND FLAKERS

EVAP ASSY (1A) 620054225, AUGER ASSY (1B) 620054230

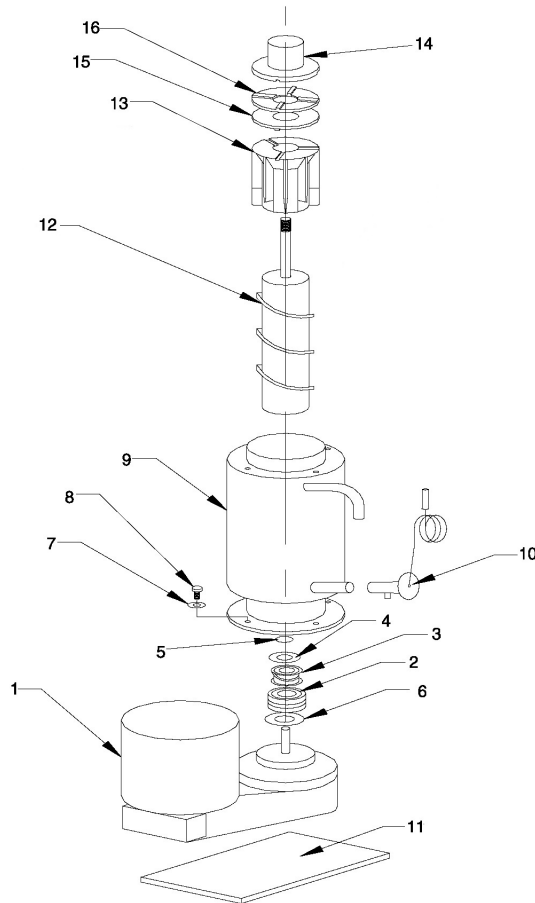

Figure 14

Item No.	Part No.	Name
(1A) 620054225		
1	638090001	GEARMOTOR LESS CABLE, SEALS, O-RING, SEAL-MOUNT 115V
	638090001-001	GEARMOTOR LESS CABLE, SEALS, O-RING, SEAL-MOUNT 230V, 60HZ
	638090050	GEARMOTOR - 115V SERVICE KIT
	638090050-004	GEARMOTOR - 230V SERVICE KIT
2	638090215	SHAFT SEAL MOUNT
3	638090051	SHAFT SEAL
4	638007301-030	WASHER, LOWER
5	638090053	E-RING
6	638090216	SHAFT SEAL SEAT

7	168833000	WASHER, LOCK 1/4 SPLIT
8	161179001	SCREW 1/4-20 X 3/4 LG. HHMS
9	630000651	EVAPORATOR ASSEMBLY
10	620068259	EXPANSION VALVE
11	638036218	BRACKET, MOUNTING
(1B) 620054230		
12	638090213	AUGER
13	638090218	EXTRUDING HEAD FOR FLAKE ICE
	630900608	EXTRUDING HEAD FOR CHUNKLET ICE
14	638090211	AUGER NUT
15	638090219	BEARING NYLON
16	638090220	BEARING DELRIN

ELECTRICAL BOX ASSEMBLY MODEL 700 SERIES

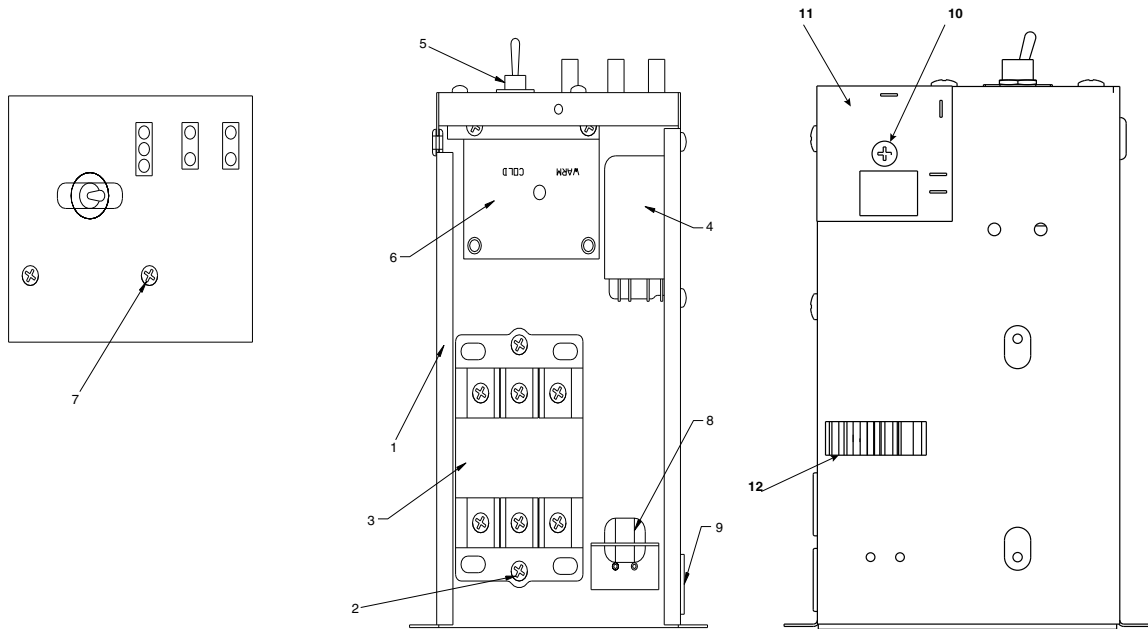

Figure 15

Item No.	Part No. 700 (115V)	Part No. 701 (208/230V)	Name	Qty.
1	630000880	630000880	ELECTRICAL BOX	1
2	638007026-03	638007026-03	SCREW 8/32 X 5/8 RHMS	2
3	638090052	638090054	CONTACTOR	1
4	638003898	638010002	RELAY	1
5	638004791	638004791	SWITCH - TOGGLE	1
6	630900946	630900947	BIN CONTROL	1
7	638007026-01	638007026-01	SCREW 8/32 X 3/8 RHMS	2
8	163424000	163424000	STRAIN RELIEF	1
9	163529000	163529000	BUSHING	1
10	07515		SCREW SM 10 TB PAPH 32 STZL	1
11	638031498		TIMER AUGER DELAY 60 SEC 120/60	1
12	620054736		CLAMP HARNESS ADJUSTABLE 0.57-0.75"	12
13	620066534		HARN CONTROL BOX WCC 700A W/AUGER DELAY	1

WCU 600 REMOTE CONDENSER

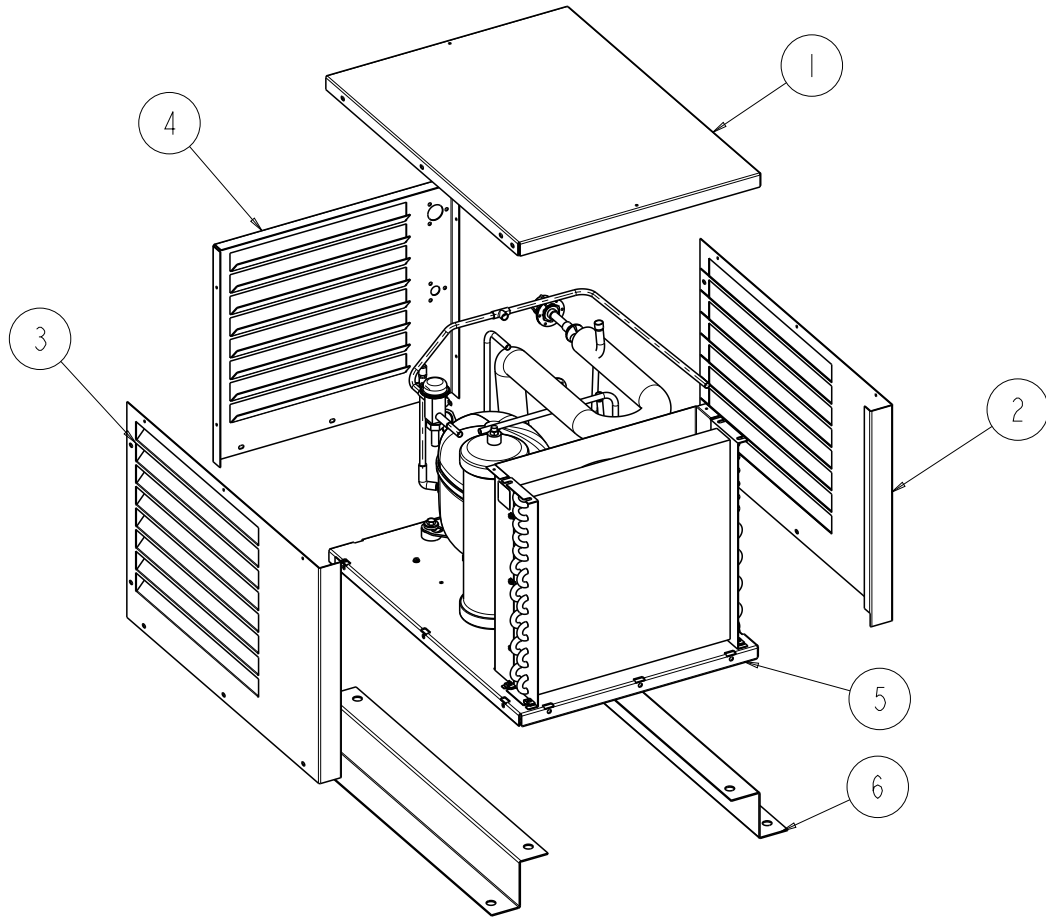

Figure 16

Item No	Part No	Description
1	638090686	COVER WCU
2	638090689	LEFT PANEL
3	638090687	RIGHT PANEL
4	638090688	BACK PANEL
5	638037056	BASE PANEL
6	638090679	RAIL RIGHT & LEFT

WCU 600 REMOTE CONDENSER

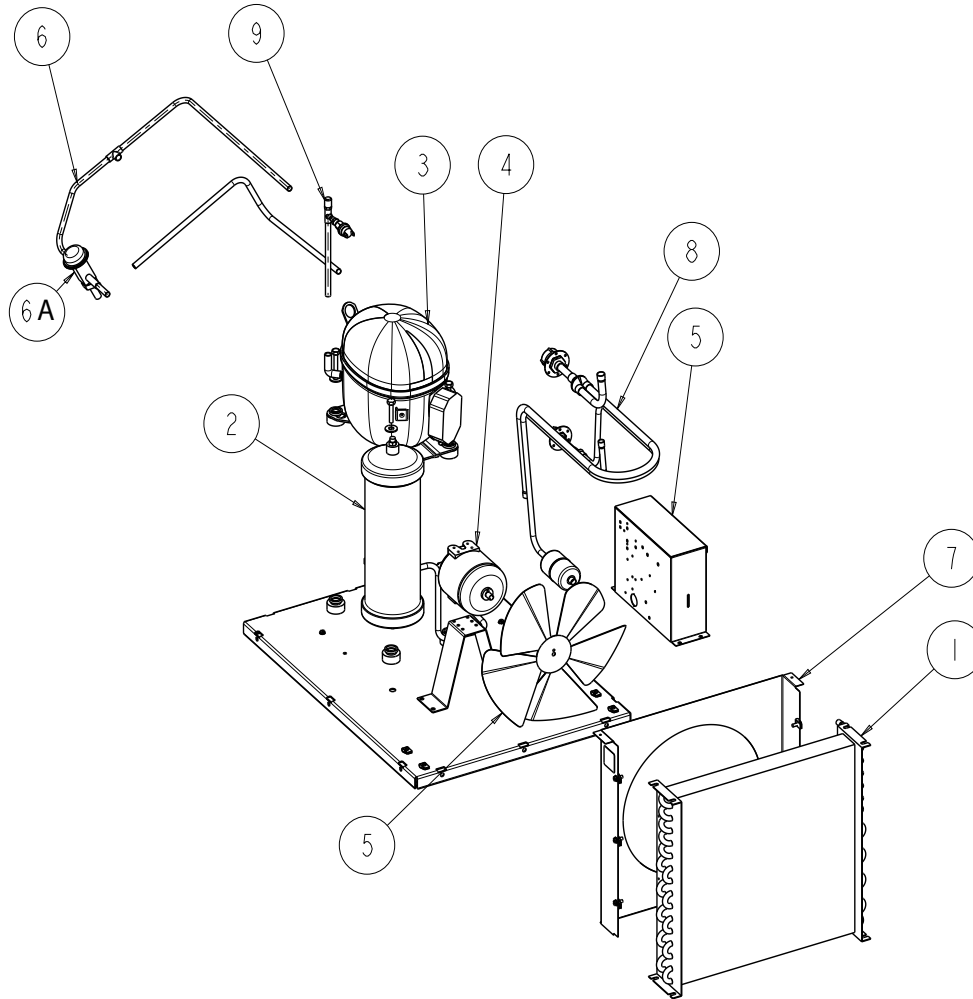

Figure 17

Item No	Part No	Description
1	638036121	COND-COIL
2	638036188	RECEIVER UPRIGHT
3	620054119	COMP- COPELAND 404A RST64C1E-CFA-201 W/PROTECTOR
4	638090683	MOTOR ASY FAN 120/60 35W
5	638036308	E-BOX
6	620057149	LINE HEADMASTER VALVE
6A	638036194	VALVE HEAD PRESSURE
7	638090682	SHROUD CONDENSER
8	620057147	TUBG SUCTION LINE ASSY
9	620057186	TUBG LOW PRESSURE SWITCH ASSY

Cornelius Inc.
www.cornelius.com