

## Economy Water Booster 2-Gallon Tank

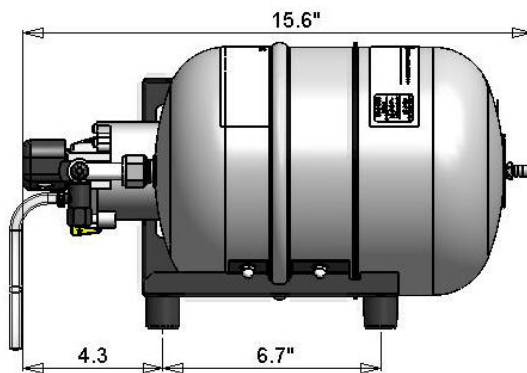
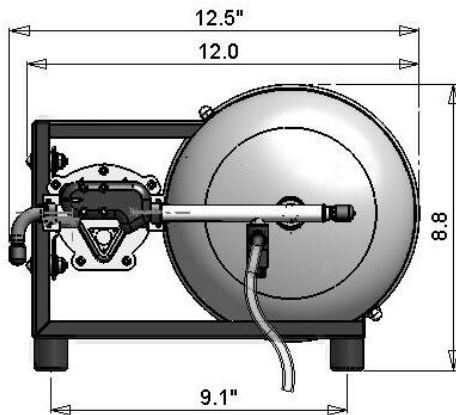
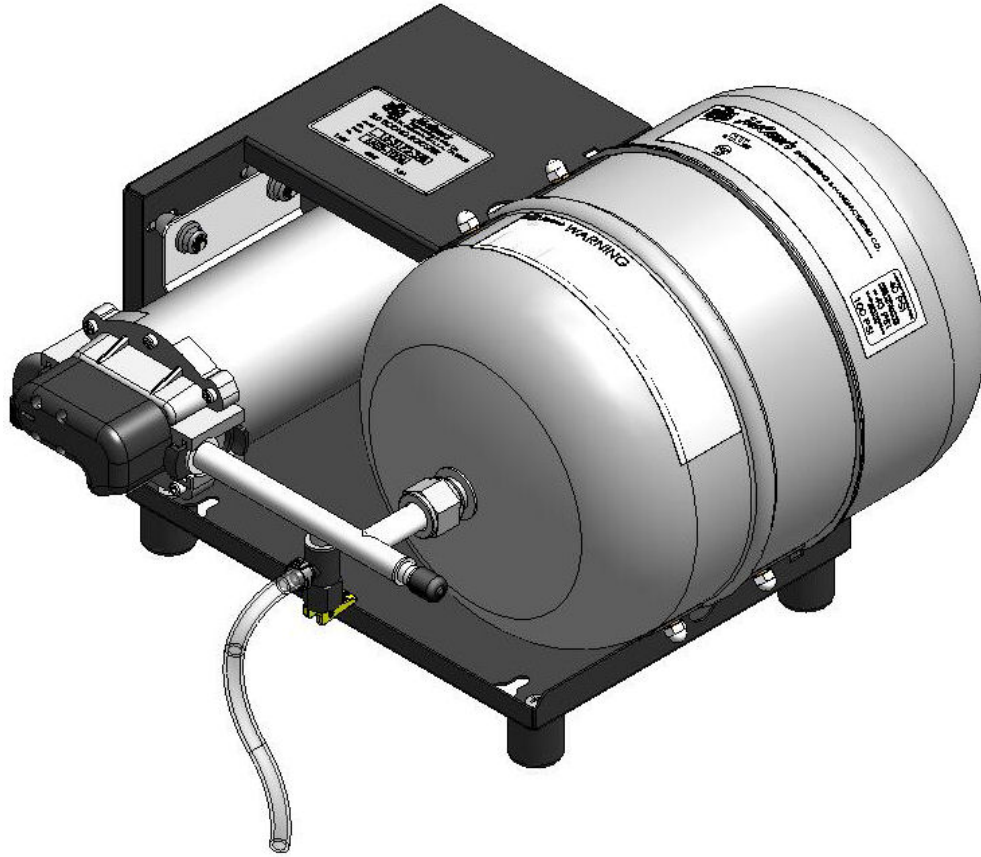

### TECHNICAL SPECIFICATION

Model	Econo-Booster 2-gal	
Part Number	16-3172-3/8"	3/8" Water connections
	16-3172-1/2"	1/2" Water connections

Dimensions	basic unit	8.8" high x 12.5" wide x 15.6" deep
Weights	basic unit	13.7 pounds
	shipping (boxed)	16.4 pounds
Connections	16-3172-3/8"	3/8" Hose Barb Water Inlet
		3/8" Hose Barb Water Outlet
	16-3172-1/2"	1/2" Hose Barb Water Inlet
		1/2" Hose Barb Water Outlet
Power Supply	115 VAC, 60 Hz	
Pump	Aquatec DDP 7800	Model # 7864-NFB2-H524-UL
	Pump Type	Positive Displacement, Diaphragm, Self-priming, RUN-DRY capable
	Construction	Ball Bearing, Thermal Protection, Nylon housing, Sanoprene diaphragm, Stainless Steel fittings.
	Power	115 VAC, 60 Hz
	Current Draw	1.3 AMP at 100PSI
	Water Supply	60 PSI max. line pressure
	ON-OFF Switching	"ON" at 75-85 PSI; "OFF" at 100 PSI nominal
	Flowrate, max.	1.3 GPM at 70 PSI
	Operating Pressure	110 PSI max.
	Agency approvals	UL; NSF Standard 58
Water Tank	Material	304 Stainless Steel
	Capacity	2 Gallons
	Discharge Capacities	21 Fl. Oz. (100-80 PSI)
		93 Fl. Oz. (100-40 PSI)
	Bladder Material	Butyl (isobutylene isoprene); NSF approved
Construction	Bladder Type, for potable water application. Hydrostatic test 900 PSI ; UL approved	

## FEATURES

- EASY OPERATION –
  - Plug-and-Run. Internal control switch determines when the pump needs to turn "ON" and "OFF".
  - Rubber feet to reduce noise and vibration.
- EASY INSTALLATION & SERVICING –
  - Unit utilizes water connections in 3/8" and 1/2" hose barb versions.
  - Unit can be placed on a counter, shelf, or can be mounted to the Wall.
  - Unit does not require strict maintenance program. As long as clean potable water supply is always available at the pump's inlet it should be trouble free.
- PROTECTION
  - Tank is made from 304 Stainless Steel. Other steel components are powder coated for corrosion protection.
  - Pump motor is thermally protected to prevent over-heating.
  - The unit has Pressure Relief Valve (PRV) that prevents the system's pressure from exceeding the preset limit.