



SERVICE PARTS MANUAL
CIM SERIES
CIM0825, CIM0826, CIM1125 & CIM1126



This parts list contains the service parts available for the following CIM Series.

CIM0826 208-230/60/1

CIM0825 220-240/50/1

CIM1126 208-230/60/1

CIM1125 220-240/50/1

Model Number Example

CIM0826HA

CIM = **C**uber **I**ce **M**achine

08 = 800 lb, in 24 hours capacity

2 = 22 inch wide cabinet

0 = 115 Volt, **5** = 220-240/50/1 **6** = 208-230/60/1 Volt

H = Half Cube Size, **F** = Full Cube Size

A = Air Cooled Condenser, **W** = Water Cooled Condenser **R**=Remote Condenser

Check the model number on the data plate and refer to the correct listing for the specific component.

Check carefully that the correct part is identified and ordered.

Table of Contents	Page 1
Cabinet	Page 2-3
Water System	Page 4-5
Air Cooled Condenser	Page 6-7
Remote Condenser	Page 8-9
Electrical	Page 10-11
Compressor	Page 12

Ice-O-Matic
11100 East 45th Ave.
Denver Co. 80239
800-423-3367

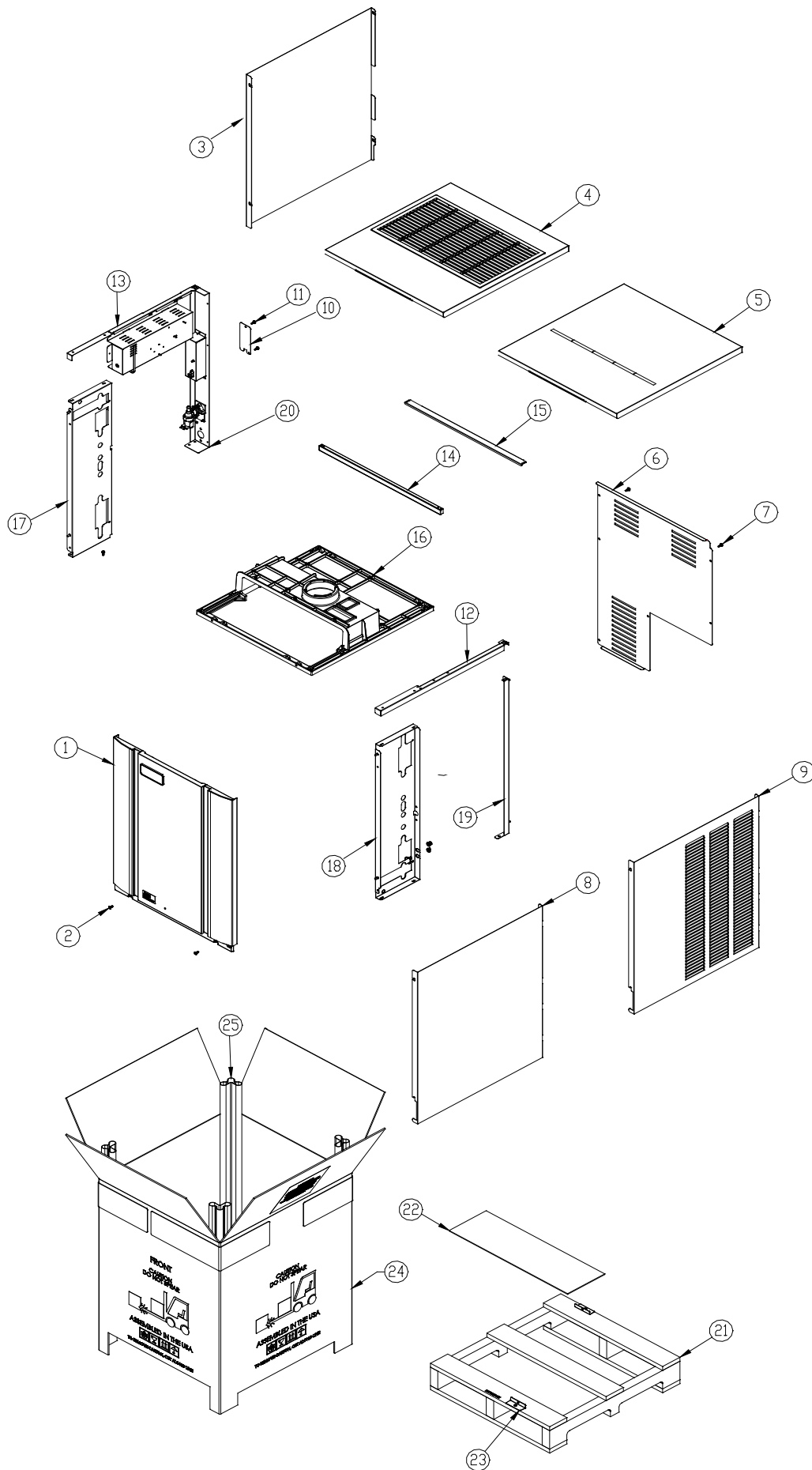

Item No.	Model Number			Description
	CIM0826		CIM1126	
1	2031545-01S		2031545-01S	Front Panel
2	9031237-01P		9031237-01P	Front Panel Screws
3	3022007-05		3022007-05	Left Side Side Panel
4	2101496-01S		2101496-01S	Top Panel-Air Cooled
5	3022012-01		3022012-01	Top Panel-Remote and Water Cooled
6	9031046-01P		9031046-01P	Rear Cover Screws
7	3013634-04		3013634-04	Rear Cover
8	3022007-06		3022007-06	Right Side Panel-Remote and Water Cooled
9	3022007-04		3022007-04	Right Side Panel-Air Cooled
10	3013674-01		3013674-01	Junction Box Cover
11	9031046-01P		9031046-01P	Junction Box Screw
12	3013691-01		3013691-01	Top Right Frame Work
13	2021810-01		2021810-01	Left Side Frame Top
14	3013637-01		3013637-01	Brace 22 Inch
15	3013636-01		3013636-01	Rear Brace
16	9051725-01		9051725-01	Base
17	2021800-01		2021800-01	Front Left Brace
18	2021800-02		2021800-02	Front Right Brace
19	2021808-01		2021808-01	Right Rear Corner
20	2021803-01		2021803-01	Left Rear Corner Post
21	9011369-03		9011369-03	Elevation Skid 22 Inch
22	9011378-02		9011378-02	Carton Liner 22 Inch
23	9051765-01		9051765-01	Shipping Bracket 2 Req. (Field Installed)
24	9011374-04		9011374-04	Carton, Elevation 22 Inch
25	9011320-06		9011320-06	Corner Post (Each), Elevation, (4 Required)
	9031026-04P		9031026-04P	Pop Rivets Not Shown (Package of 10)

	CIM0825		CIM1125		Description
1	2031545-01S		2031545-01S		Front Panel
2	9031237-01P		9031237-01P		Front Panel Screws
3	3022007-05		3022007-05		Left Side Side Panel
4	2101496-01S		2101496-01S		Top Panel-Air Cooled
5	3022012-01		3022012-01		Top Panel-Remote and Water Cooled
6	9031046-01P		9031046-01P		Rear Cover Screws
7	3013634-04		3013634-04		Rear Cover
8	3022007-06		3022007-06		Right Side Panel-Remote and Water Cooled
9	3022007-04		3022007-04		Right Side Panel-Air Cooled
10	3013674-01		3013674-01		Junction Box Cover
11	9031046-01P		9031046-01P		Junction Box Screw
12	3013691-01		3013691-01		Top Right Frame Work
13	2021810-01		2021810-01		Left Side Frame Top
14	3013637-01		3013637-01		Brace 22 Inch
15	3013636-01		3013636-01		Rear Brace
16	9051725-01		9051725-01		Base
17	2021800-01		2021800-01		Front Left Brace
18	2021800-02		2021800-02		Front Right Brace
19	2021808-01		2021808-01		Right Rear Corner
20	2021803-01		2021803-01		Left Rear Corner Post
21	9011369-03		9011369-03		Elevation Skid 22 Inch
22	9011378-02		9011378-02		Carton Liner 32 Inch
23	9051765-01		9051765-01		Shipping Bracket 2 Req. (Field Installed)
24	9011374-04		9011374-04		Carton, Elevation 22 Inch
25	9011320-06		9011320-06		Corner Post (Each), Elevation, (4 Required)
	9031026-04P		9031026-04P		Pop Rivets Not Shown (Package of 10)

Note: When ordering an evaporator from Serial Number 1710 to and including Serial Number 1802, the Lower Curtain Assembly PN 9051736-01 must be ordered due to the evaporator plastic configuration.

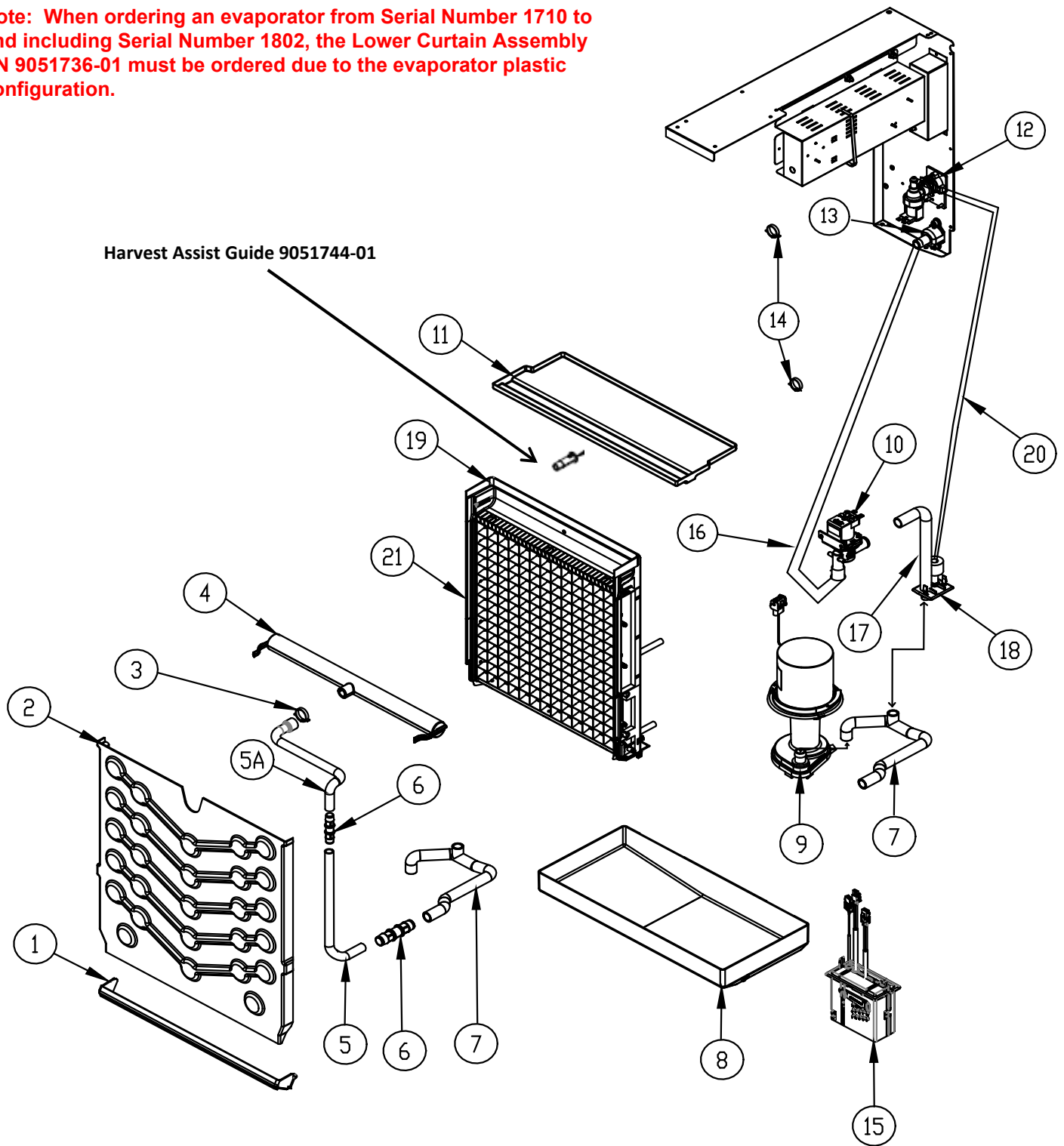

The Model Number of the machine has a designator for the Cube Size

Example: **CIM0826FA** **F = Full Cube**

CIM0826HA **H = Half Cube**

Item No.	Model Number			Description
	CIM0826		CIM1126	
1	9051736-01		9051736-01	Lower Curtain Assembly
2	9051760-01		9051760-01	Evaporator Cover
3	9021010-05		9021010-05	Hose Clamp, Plastic
4	9051766-01		9051766-01	Water Distribution Tube Assembly
5	9051749-05		9051749-05	Water Tube, Side
5A	9051780-01		9051780-01	Water Tube Upper (Restricted)
6	9091177-02		9091177-02	Coupler, Straight, 5/8 I.D. Tubing
7	9051748-01		9051748-01	Water Tube, Sump
8	9051737-01		9051737-01	Sump/Water Trough
9	2062336-03S		2062336-03S	Water Pump
10	9041105-05		9041105-05	Purge Valve
11	9051738-01		9051738-01	Top Cover
12	9041108-02		9041108-02	Water Inlet Valve
13	9091140-01		9091140-01	Drain Fitting
14	9021010-04		9021010-04	Hose Clamp, Plastic
15	1051224-01		1051224-01	Float Switch Assembly (Includes Instructions)
16	9051781-31		9051781-31	Purge Valve Tubing to Drain
17	9051541-01		9051541-01	Purge Valve Tube to Inlet Outlet Bracket
18	9051739-01		9051739-01	Inlet Outlet Bracket
19	1051380-01		1051380-01	Evaporator-FULL Cube tp (1051223-05 NLA)
19	1051380-02		1051380-02	Evaporator-HALF Cube tp (1051223-06 NLA)
20	9051781-36		9051781-36	Water Inlet Valve to Inlet Outlet Bracket Tube
21				
	208-230/60/1		208-230/60/1	← Machine Voltage

The Model Number of the machine has a designator for the Cube Size

Example: CIM0826EA F = Full Cube Cube Size = 7/8 x 7/8 x 7/8
 CIM0826HA H = Half Cube Cube Size = 3/8 x 7/8 x 7/8

Item No.	Model Number 220-240/50/1			Description
	CIM0825		CIM1125	
1	9051736-01		9051736-01	Lower Curtain Assembly
2	9051760-01		9051760-01	Evaporator Cover
3	9021010-05		9021010-05	Hose Clamp, Plastic
4	9051766-01		9051766-01	Water Distribution Tube Assembly
5	9051749-05		9051749-05	Water Tube, Side
5A	9051749-03		9051749-03	Water Tube Upper
6	9091177-02		9091177-02	Coupler, Straight, 5/8 I.D. Tubing
7	9051748-01		9051748-01	Water Tube, Sump
8	9051737-01		9051737-01	Sump/Water Trough
9	2062336-03S		2062336-03S	Water Pump
10	9041105-05		9041105-05	Purge Valve
11	9051738-01		9051738-01	Top Cover
12	9041108-02		9041108-02	Water Inlet Valve
13	9091140-01		9091140-01	Drain Fitting
14	9021010-04		9021010-04	Hose Clamp, Plastic
15	1051224-01		1051224-01	Float Switch Assembly (Includes Instructions)
16	9051781-31		9051781-31	Purge Valve Tubing to Drain
17	9051541-01		9051541-01	Purge Valve Tube to Inlet Outlet Bracket
18	9051739-01		9051739-01	Inlet Outlet Bracket
19	1051380-01		1051380-01	Evaporator-FULL Cube tp (1051223-05 NLA)
19	1051380-02		1051380-02	Evaporator-HALF Cube tp (1051223-06 NLA)
20	9051781-36		9051781-36	Water Inlet Valve to Inlet Outlet Bracket Tube
21				
				← Machine Voltage

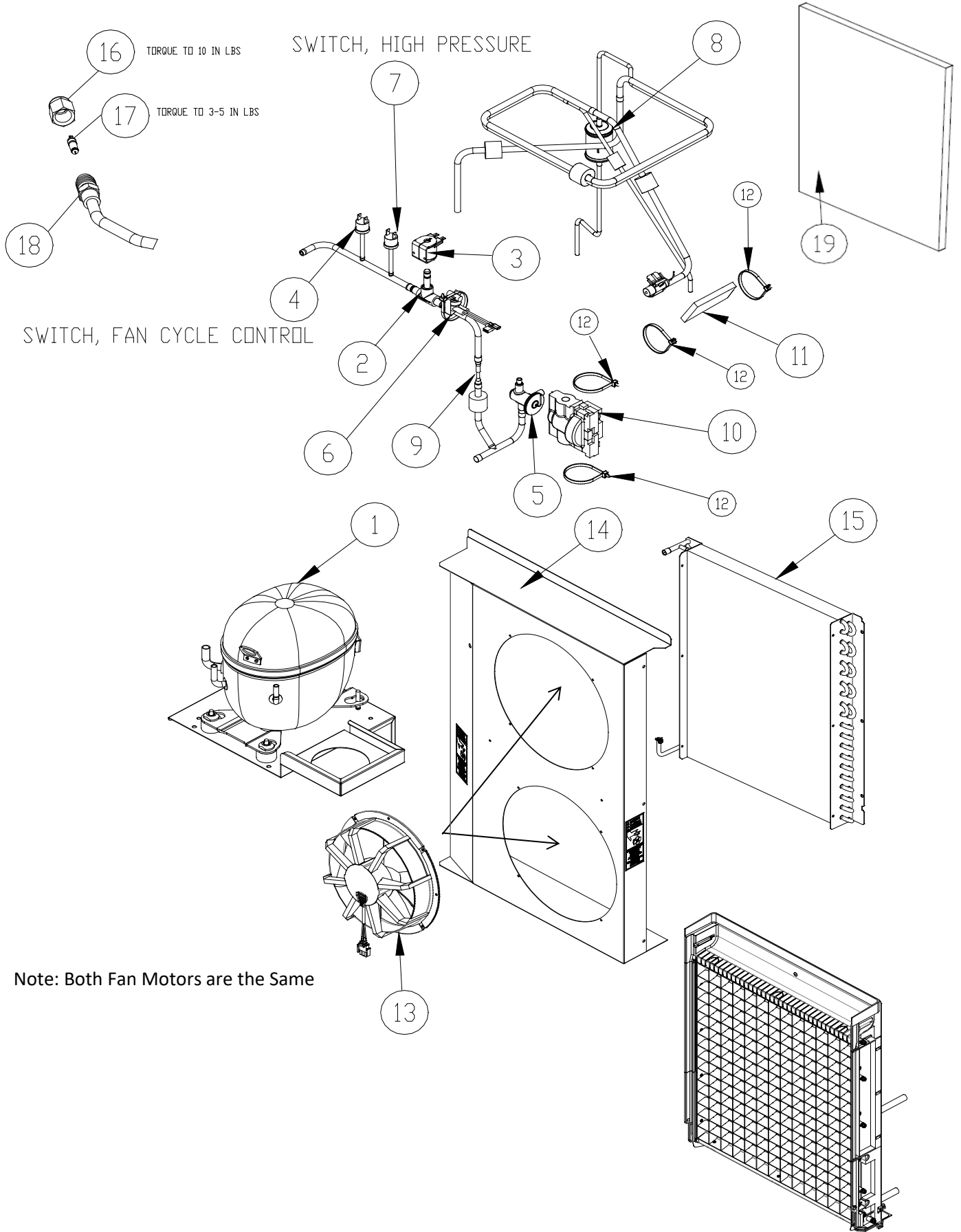

Item No.	Model Number				Description
	CIM0826A		CIM1126A		
1B	9181177-11		9181180-11		Compressor Kit RED= NLA , Use the 105 Kit Below
1BC	1051239-01		1051240-01		Compressor Kit, Bristol to Copeland
1CR1	9181139-11		9181240-11		Compressor (Revision 1 Series)
			9151198-01		Hot Gas valve Body (Revision 1 Series)
2	9151192-01		9151192-02		Hot Gas Valve Body
3	9151193-02		9151193-02		Hot Gas Valve Coil (240 V)
4	9041106-01		9041106-01		Switch, Fan Cycle
5	9151152-101		9151152-101		TXV
6	9041098-02		9041098-02		High Temp Switch
7	9041111-01		9041111-01		Switch, High Pressure
8	9151163-03		9151163-03		Drier (Included in Compressor Kit)
9	Not Used		Not Used		Restrictor
10	9131544-01		9131544-01		Insulation, TXV
11	9131143-07		9131143-07		Insulation, Bulb
12	9021021-01		9021021-01		Cable Tie-For TXV and Bulb Insulation
13	9161135-02		9161135-02		Fan Motor Assembly (Both Motors the Same)
13	9161143-02		9161143-02		Fan Motor Assembly (Revision 1)
14	3013697-02		3013697-02		Fan Shroud
15	9141153-01		9141153-01		Condenser
16	9091086-03		9091086-03		Service Valve Cap
17	9091086-02		9091086-02		Service Valve Core
18	9091086-01		9091086-01		Service Valve Stem
19	AFK-2		AFK-2		Air Filter
	208-230/60/1		208-230/60/1		← Machine Voltage

Item No.	Model Number				Description
	CIM0825A		CIM1125A		
1B	9181176-11		9181182-11		Compressor Kit RED= NLA , Use the 105 Kit Below
1BC	1051240-02		1051241-02		Compressor Kit, Bristol to Copeland
1CR1	9181140-12		9181141-12		Compressor (Revision 1 Series)
2	9151192-01		9151192-02		Hot Gas Valve Body
3	9151193-02		9151193-02		Hot Gas Valve Coil (240 V)
4	9041106-01		9041106-01		Switch, Fan Cycle
5	9151152-101		9151152-101		TXV
6	9041098-02		9041098-02		High Temp Switch
7	9041111-01		9041111-01		Switch, High Pressure
8	9151163-03		9151163-03		Drier (Included in Compressor Kit)
9	Not Used		Not Used		Restrictor
10	9131544-01		9131544-01		Insulation, TXV
11	9131143-07		9131143-07		Insulation, Bulb
12	9021021-01		9021021-01		Cable Tie-For TXV and Bulb Insulation
13	9161135-02		9161135-02		Fan Motor Assembly (Both Motors the Same)
13	9161143-02		9161143-02		Fan Motor Assembly (Revision 1)
14	3013697-02		3013697-02		Fan Shroud
15	9141153-01		9141153-01		Condenser
16	9091086-03		9091086-03		Service Valve Cap
17	9091086-02		9091086-02		Service Valve Core
18	9091086-01		9091086-01		Service Valve Stem
19	AFK-2		AFK-2		Air Filter
	220-240/50/1		220-240/50/1		← Machine Voltage

1B Originally Supplied with a Bristol Compressor, Bristol Compressors are No Longer Available

1BC Converts from a Bristol Compressor to a Copeland Kit

1CR1 Built with a Copeland Compressor, Rev 1

Reference Page 14 for Compressor Starting Components

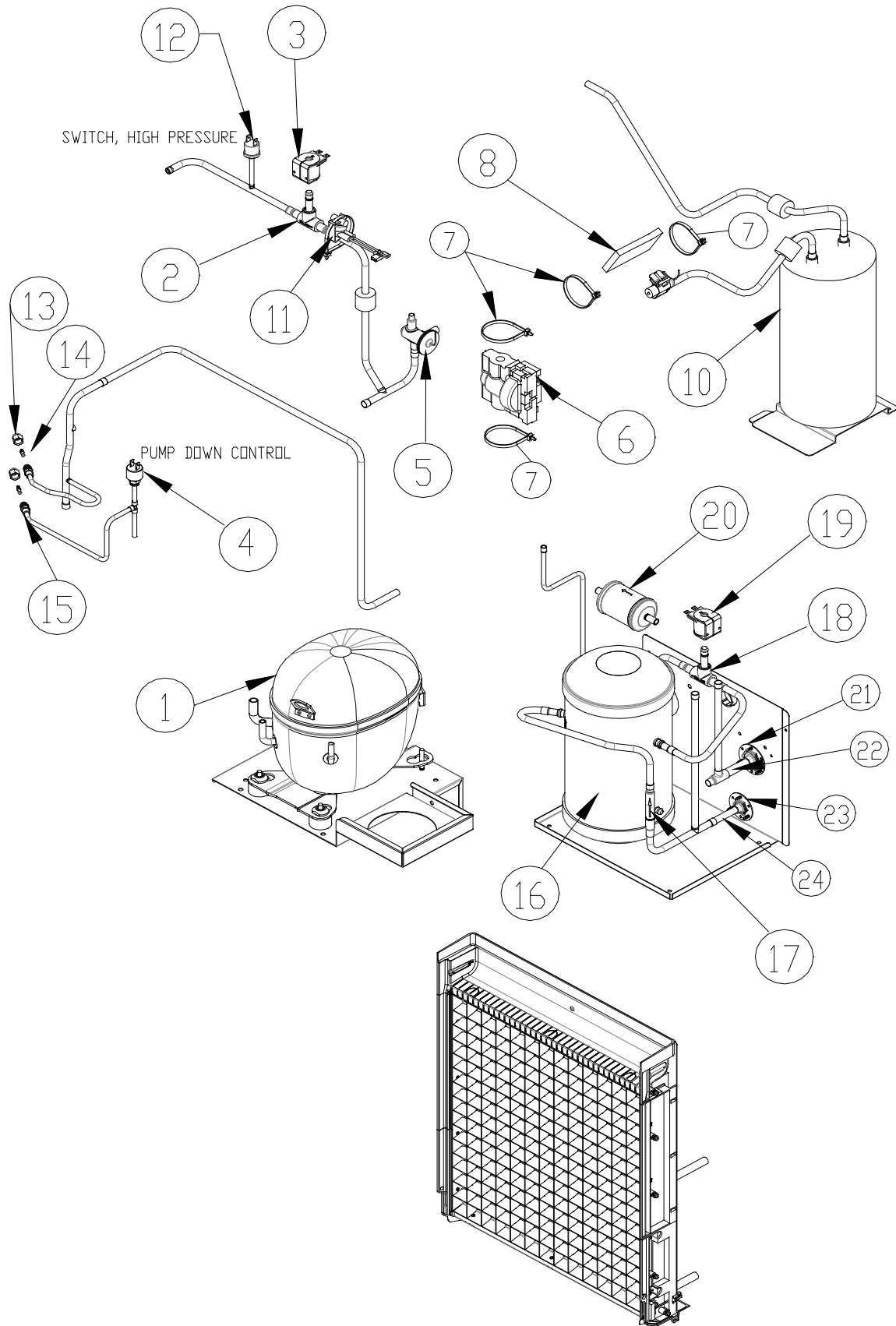

REFERENCE PAGE 4 AND 5 FOR EVAPORATOR

Item No.	Model Number				Description
	CIM0826R	CIM0825R	CIM1126R	CIM1125R	
1B	9181177-01	9181176-01	9181180-11	9181182-11	Compressor Kit RED=NLA Uses 105 Kit Below
1BC	1051239-01	1051240-02	1051240-01	1051241-02	Compressor Kit (Bristol to Copeland)
1CR1	9181139-11	9181140-12	9181240-11	9181141-12	Compressor (Revision 1 Series)
2	9151192-01	9151192-01	9151192-02	9151192-02	Hot Gas Valve Body
3	9151193-02	9151193-02	9151193-02	9151193-02	Hot Gas Valve Coil
4	9041092-02	9041092-02	9041092-02	9041092-02	Pump Down Control
5	9151152-101	9151152-101	9151152-101	9151152-101	TXV
6	9131544-01	9131544-01	9131544-01	9131544-01	Insulation, TXV
7	9021025-01	9021025-01	9021025-01	9021025-01	Cable Tie-For TXV and Bulb Insulation
8	9131143-07	9131143-07	9131143-07	9131143-07	Insulation, TXV Bulb
9	NA	NA	NA	NA	Pressure Control Valve
10	NA	NA	NA	NA	Accumulator
11	9041098-02	9041098-02	9041098-02	9041098-02	High Temp Switch
12	9041111-01	9041111-01	9041111-01	9041111-01	Switch, High Pressure
13	9091086-03	9091086-03	9091086-03	9091086-03	Service Valve Cap
14	9091086-02	9091086-02	9091086-02	9091086-02	Service Valve Core
15	9091086-01	9091086-01	9091086-01	9091086-01	Service Valve Stem
16	9151060-01	9151060-01	9151060-01	9151060-01	Receiver
17	9151139-01	9151139-01	9151139-01	9151139-01	Check Valve
18	9151192-02	9151192-02	9151192-02	9151192-02	Liquid Line Solenoid
19	9151193-02	9151193-02	9151193-02	9151193-02	Liquid Line Coil
20	9151163-03	9151163-03	9151163-03	9151163-03	Drier (Included in Compressor Kit)
21	9091001-09	9091001-09	9091001-09	9091001-09	1/2 Inch Coupling Flange (Large)
22	9091001-12	9091001-12	9091001-12	9091001-12	1/2 Inch Coupling (Large)
23	9091001-03	9091001-03	9091001-03	9091001-03	3/8 Inch Coupling Flange (Small)
24	9091001-11	9091001-11	9091001-11	9091001-11	3/8 Inch Coupling (Small)
	208-230/60/1	220-240/50/1	208-230/60/1	220-240/50/1	← Machine Voltage

1B Originally Supplied with a Bristol Compressor, Bristor Compressors are No Longer Available

1BC Converts from a Bristol Compressor to a Copeland Kit

1CR1 Built with a Copeland Compressor, Rev 1

Reference Page 14 for Compressor Starting Components

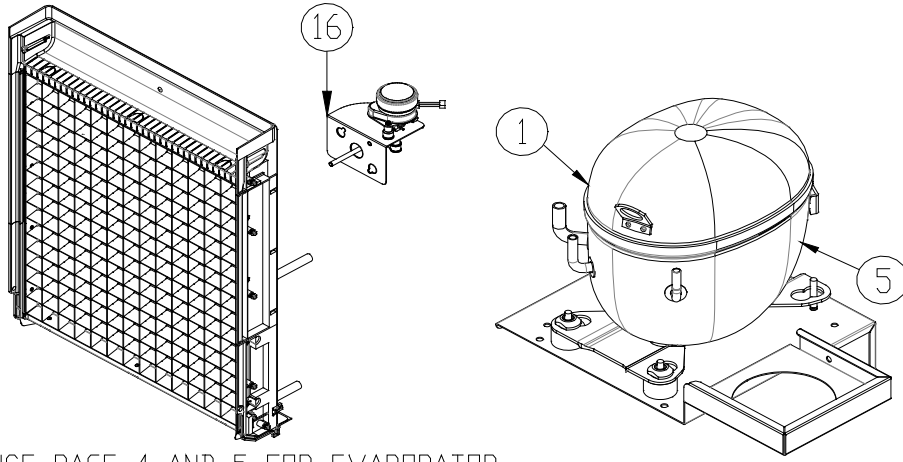

REFERENCE PAGE 4 AND 5 FOR EVAPORATOR

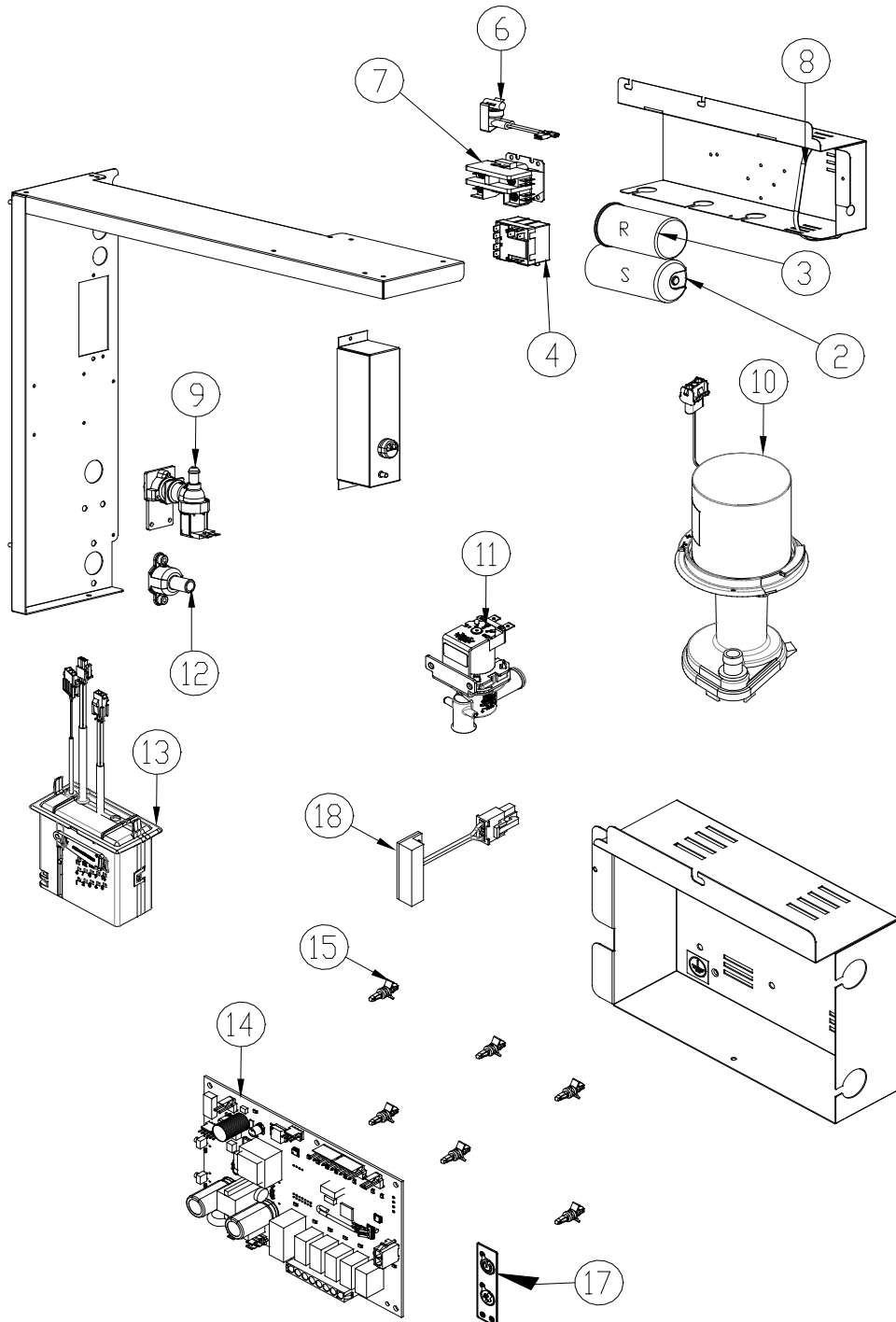

Item No.	Model Number					
	Reference Page 14 for Compressor Components					
	CIM826A	CIM826A1	CIM1126A	CIM1126A1	CIM1126R/R1	
6	9041098-02	9041098-02	9041098-02	9041098-02	9041098-02	Switch, High Temp
7	9101002-06	9101002-06	9101002-06	9101002-06	9101002-06	Contactactor
8	9021096-01	9021096-01	9021096-01	9021096-01	9021096-01	Cable Tie, Metal
9	9041108-02	9041108-02	9041108-02	9041108-02	9041108-02	Valve, Water Inlet
10	2062336-03S	2062336-03S	2062336-03S	2062336-03S	2062336-03S	Water Pump
11	9041105-05	9041105-05	9041105-05	9041105-05	9041105-05	Purge Valve
12	9091140-01	9091140-01	9091140-01	9091140-01	9091140-01	Purge Drain
13	1051224-01	1051224-01	1051224-01	1051224-01	1051224-01	Float Switch Assembly (Includes Instructions)
14	9101368-02	9101368-02	9101368-02	9101368-02	9101368-02	Board Dual Voltage
15	9051698-01P	9051698-01P	9051698-01P	9051698-01P	9051698-01P	Plastic Standoff, Control Board (Pkg of 10)
16	9161134-02	9161134-02	9161134-02	9161134-02	9161134-02	Harvest Assist
17	9101394-01	9101394-01	9101394-01	9101394-01	9101394-01	Membrane Switch
18	9101379-01	9101379-01	9101379-01	9101379-01	9101379-01	Switch, Magnetic Reed (Bin Control On Evap)
	208-230/60/1	208-230/60/1	208-230/60/1	208-230/60/1	208-230/60/1	← Machine Voltage

Item No.	Model Number					
	Reference Page 14 for Compressor Components					
	CIM825A	CIM825A1	CIM1125A	CIM1125A1	CIM1125R/R1	
6	9041098-02	9041098-02	9041098-02	9041098-02	9041098-02	Switch, High Temp
7	9101002-08	9101002-08	9101002-08	9101002-08	9101002-08	Contactactor
8	9021096-01	9021096-01	9021096-01	9021096-01	9021096-01	Cable Tie, Metal
9	9041108-02	9041108-02	9041108-02	9041108-02	9041108-02	Valve, Water Inlet
10	2062336-03S	2062336-03S	2062336-03S	2062336-03S	2062336-03S	Water Pump
11	9041105-05	9041105-05	9041105-05	9041105-05	9041105-05	Purge Valve
12	9091140-01	9091140-01	9091140-01	9091140-01	9091140-01	Purge Drain
13	1051224-01	1051224-01	1051224-01	1051224-01	1051224-01	Float Switch Assembly (Includes Instructions)
14	9101368-02	9101368-02	9101368-02	9101368-02	9101368-02	Board Dual Voltage
15	9051698-01P	9051698-01P	9051698-01P	9051698-01P	9051698-01P	Plastic Standoff, Control Board (Pkg of 10)
16	9161134-02	9161134-02	9161134-02	9161134-02	9161134-02	Harvest Assist
17	9101394-01	9101394-01	9101394-01	9101394-01	9101394-01	Membrane Switch (Includes Cable)
18	9101379-01	9101379-01	9101379-01	9101379-01	9101379-01	Switch, Magnetic Reed (Bin Control On Evap)
	220-240/50/1	220-240/50/1	220-240/50/1	220-240/50/1	220-240/50/1	← Machine Voltage

CIM0826A		CIM1126A			Model Number
9181177-11		9181180-11			Compressor
9181003-44		9181003-44			Start Capacitor
9181009-16		9181009-16			Run Capacitor
9181010-37		9181010-33			Potential Relay
Internal		Internal			Overload
CIM0826R	CIM0825R	CIM1126R	CIM1125R		Model Number
9181177-01	9181176-01	9181180-11	9181182-11		Compressor
9181003-07	9181003-32	9181003-44	9181003-07		Start Capacitor
9181009-16	9181009-17	9181009-12	9181009-12		Run Capacitor
9181010-12	9181010-04	9181010-10	9181010-12		Potential Relay
internal	internal	internal	internal		Overload
CIM0825A		CIM1125A			Model Number
9181176-11		9181182-11			Compressor
9181003-53		9181003-56			Start Capacitor
9181009-16		9181009-27			Run Capacitor
9181010-36		9181010-35			Potential Relay
Internal		Internal			Overload

Reference the Bristol Model Number for Compressor Starting Compants	1051239-01 Copeland Kit	9181176-11	Bristol R92J243ABKA
	1051240-01 Copeland Kit	9181177-11	Bristol R92J223ABCA
	1051240-02 Copeland Kit	9181180-11	Bristol R92J273ABCA
	1051241-02 Copeland Kit	9181182-11	Bristol R92J343ABKA

Reference the Copeland Model Number for Compressor Starting Compants	1051239-01	Copeland	9181139-11	CS10K6E-PFV-255
	1051240-01	Copeland	9181240-11	CS12KIE-PFV-255
	1051240-02	Copeland	9181140-12	CS12K6E-PFJ-255
	1051241-02	Copeland	9181141-12	CS14K6E-PFJ-255

9181139-11	9181140-12	9181240-11	9181141-12	Compressor Kit
9181003-07	9181003-32	9181003-44	9181003-07	Start Capacitor
9181009-16	9181009-17	9181009-12	9181009-12	Run Capacitor
9181010-12	9181010-04	9181010-10	9181010-12	Potential Relay
Internal	Internal	Internal	Internal	Overload