





372

PRODUCT SPECIFICATIONS



Capacity

Electric Frequency	60 Hz			50 Hz		
	Dispenser Type	Air-Cooled	Remote	Water-Cooled	Air-Cooled	Remote
Barrel Volume	128 oz	N/A	N/A	3,785 mL	N/A	N/A
Continuous Draw - Single Barrel [§]	1,680 oz/hr	N/A	N/A	49,684 mL/hr	N/A	N/A
Continuous Draw - Alternating Barrels [§]	1,800 oz/hr	N/A	N/A	53,232 mL/hr	N/A	N/A
Recovery Time [§]	7 mins	N/A	N/A	7 mins	N/A	N/A
Refrigeration	6,400 BTU/hr (6,752 kJ/hr), R-404A/R-448A [†]					
Agency	NSF 18  UL/CSA 60335-1  Complies with UL 60335-1; UL 60335-2-89; IEC 60335-2-75.			Complies with IEC/EN 60335-1; IEC/EN 60335-2-75; IEC/EN 60335-2-89; IEC/EN 61000-3-2; IEC/EN 61000-3-3; CISPR 14-1; CISPR 14-2.		

[§] Testing completed at 75°F (24°C).

^{||} Volume varies based on barrel faceplate.

[†] R-404A and R-448A refrigeration systems are functionally equivalent.

Electrical Requirements[‡]

Electric Frequency	60 Hz	50 Hz
Voltage	215 - 245 VAC ^Δ , Single Phase	215 - 245 VAC ^Δ , Single Phase
Current/Power	20 Amps	3,000 W
Receptacle	NEMA #L6-20R, 3 Wire	Varies depending on market.
Beater Motor	(2) 1/6 HP, 0.85 A	(2) 1/6 HP, 0.81 A
Fan Motor	(1) 1/6 HP, 0.43 A	(1) 1/10 HP, 0.36 A

[‡] General requirements only. Always check dispenser nameplate label for specific rating information.

^Δ Buck-boost transformer or AVR required for operation outside this range.

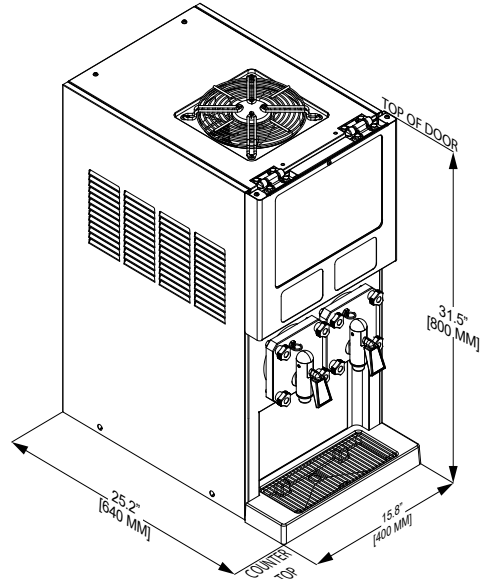
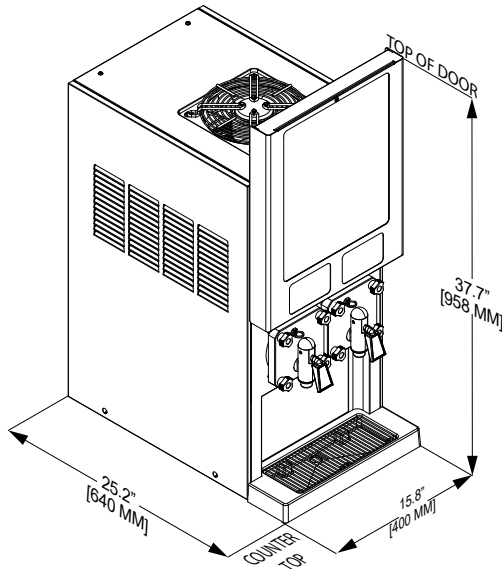

Weights & Dimensions

Measuring System	Imperial			Metric		
	Short Door		Tall Door	Short Door		Tall Door
Door Model	Short Door		Tall Door	Short Door		Tall Door
Height	31.5 in		37.7 in	800 mm		958 mm
Width	15.8 in			400 mm		
Depth	25.2 in			640 mm		
Back/Side Clearance (Min.)	2 in			51 mm		
Top Clearance (Min.)	12 in			305 mm		
Duratrans	9 ¹¹ / ₁₆ in x 13 ⁹ / ₁₆ in		15 ³ / ₄ in x 13 ⁹ / ₁₆ in	246 mm x 345 mm		400 mm x 345 mm
Flavor Card	4 ⁷ / ₈ in x 3 ¹ / ₂ in			124 mm x 89 mm		
Dispenser Type	Air-Cooled	Remote	Water-Cooled	Air-Cooled	Remote	Water-Cooled
Empty Weight	196 lbs	N/A	N/A	89 kg	N/A	N/A
Operating Weight	212 lbs	N/A	N/A	96 kg	N/A	N/A

Water, CO₂ and Syrup Requirements

Measuring System	Imperial	Metric
Water System Input	3/8" Supply Line, 30 PSIG Flowing (minimum)	3/8" Supply Line, 207 kPag Flowing (minimum)
CO ₂ System Input	70 - 72 PSIG (maximum)	483 - 496 kPag (maximum)
Condenser Water Inlet Flow Rate ^o	N/A	N/A
Condenser Water Inlet Temperature ^o	N/A	N/A
Syrup	Input: 70 - 72 PSIG (482 - 496 kPag)	
	Bag-In-Box (BIB) Connections, (2) Base Syrups	

^o For water-cooled dispensers.