





373

PRODUCT SPECIFICATIONS



Capacity

Electric Frequency	60 Hz			50 Hz		
	Air-Cooled	Remote	Water-Cooled	Air-Cooled	Remote	Water-Cooled
Barrel Volume	128 oz	N/A	N/A	-	N/A	N/A
Continuous Draw - Single Barrel [§]	1,920 oz/hr	N/A	N/A	-	N/A	N/A
Continuous Draw - Alternating Barrels [§]	2,160 oz/hr	N/A	N/A	-	N/A	N/A
Recovery Time [§]	10 mins	N/A	N/A	-	N/A	N/A
Refrigeration	6,400 BTU/hr (6,752 kJ/hr), R-404A/R-448A [†]					
Agency	NSF 18  UL/CSA 60335-1 			Complies with IEC/EN 60335-1; IEC/EN 60335-2-75; IEC/EN 60335-2-89; IEC/EN 61000-3-2; IEC/EN 61000-3-3; CISPR 14-1; CISPR 14-2.		
	Complies with UL 60335-1; UL 60335-2-89; IEC 60335-2-75.					

[§] Testing completed at 75°F (24°C).

^{||} Volume varies based on barrel faceplate.

[†] R-404A and R-448A refrigeration systems are functionally equivalent.

Electrical Requirements[‡]

Electric Frequency	60 Hz	50 Hz
Voltage	215 - 245 VAC ^Δ , Single Phase	215 - 245 VAC ^Δ , Single Phase
Current/Power	20 Amps	3,120 W
Receptacle	NEMA #L6-20R, 3 Wire	Varies depending on market.
Beater Motor	(3) 1/6 HP, 0.85 A	(3) 1/6 HP, 0.81 A
Fan Motor	(1) 1/10 HP, 0.43 A	(1) 1/10 HP, 0.63 A

[‡] General requirements only. Always check dispenser nameplate label for specific rating information. ^Δ Buck-boost transformer or AVR required for operation outside this range.

ROHS Compliant. FBD strives for continuous improvements and engineering innovations. Equipment design and/or specifications may change without notice.

©2024, FBD Partnership, L.P. FBD®, the FBD logo, and "Everyone Loves Frozen®" are trademarks of FBD Partnership, L.P., all rights reserved.

24-373S-0001_03

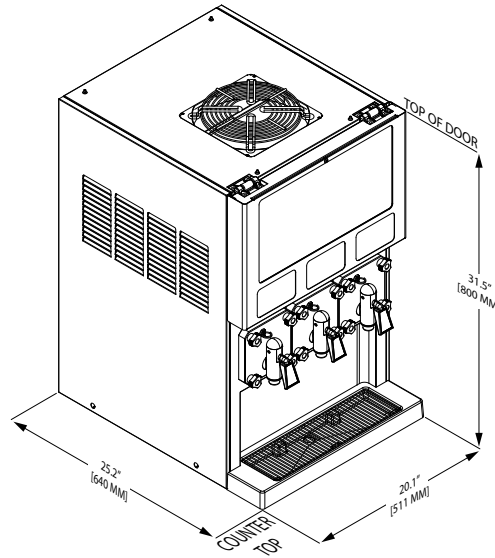

Weights & Dimensions

Measuring System	Imperial			Metric		
Door Model	Short Door		Tall Door	Short Door		Tall Door
Height	31.5 in		N/A	800 mm		N/A
Width	20.1 in			511 mm		
Depth	25.2 in			640 mm		
Back/Side Clearance (Min.)	2 in			51 mm		
Top Clearance (Min.)	12 in			305 mm		
Duratrans	9 1/2 in x 17 15/16 in		N/A	241 mm x 456 mm		N/A
Flavor Card	4 7/8 in x 3 1/2 in			124 mm x 89 mm		
Dispenser Type	Air-Cooled	Remote	Water-Cooled	Air-Cooled	Remote	Water-Cooled
Empty Weight	215 lbs	N/A	N/A	98 kg	N/A	N/A
Operating Weight	239 lbs	N/A	N/A	108 kg	N/A	N/A

Water, CO₂ and Syrup Requirements

Measuring System	Imperial	Metric
Water System Input	3/8" Supply Line, 30 PSIG Flowing (minimum)	3/8" Supply Line, 207 kPag Flowing (minimum)
CO ₂ System Input	70 - 72 PSIG (maximum)	483 - 496 kPag (maximum)
Condenser Water Inlet Flow Rate ^o	N/A	N/A
Condenser Water Inlet Temperature ^o	N/A	N/A
Syrup	Input: 70 - 72 PSIG (483 - 496 kPag)	
	Bag-In-Box (BIB) Connections, (3) Base Syrups	

^o For water-cooled dispensers.