

PROJECT: _____
 ITEM # _____ QTY: _____
 MODEL # _____
 AIA # _____ SIS # _____

CIM UNDERCOUNTER

CIMU220FA90



Features and Benefits

- Durable nickel-plated evaporator plates for long-lasting, reliable ice production.
- Front-breathing design allows installation in tight or enclosed spaces.
- Harvest Assist technology helps maintain consistent ice production while reducing energy use.
- Corrosion-resistant, fingerprint-resistant stainless steel exterior for durability and easy cleaning.
- One-Touch Cleaning makes routine maintenance fast and simple.
- Easy-to-read control display for quick adjustments, cleaning, and status checks



Warranty

- Ice Maker: **3 Years Parts and Labor**
- Evaporator and Compressor: **5 Years Parts**
- Evaporator: **7 Years Parts and Labor**
(if enrolled in the filter program for US & Canada)

Water Filter

- Manifold System IFQ1-S gets replacement filter IOMQ-S

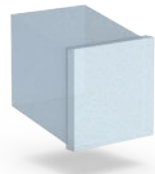

ICE FORMS	
FULL CUBE	7/8 x 7/8 x 7/8 in.
	22 x 22 x 22 mm



STORAGE CAPACITY	
Capacity	74 lbs (33.5 kg)
Width	24.54 in (623 mm)

Line drawing note: Numbers with quote symbol " are in inches. Numbers enclosed in [brackets] are in millimeters.

PLAN / TOP VIEW

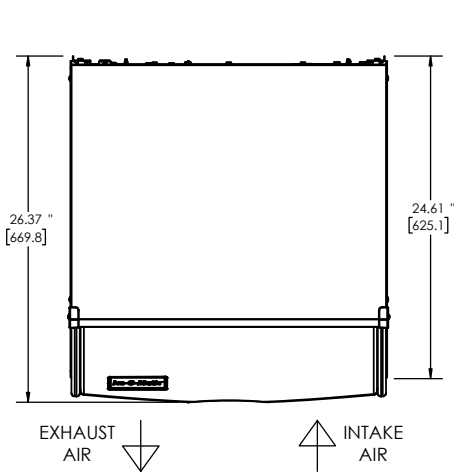

ELEVATION / FRONT VIEW

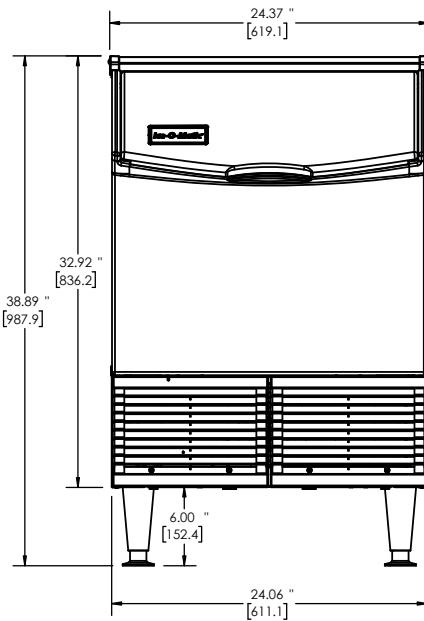

UTILITIES / BACK VIEW

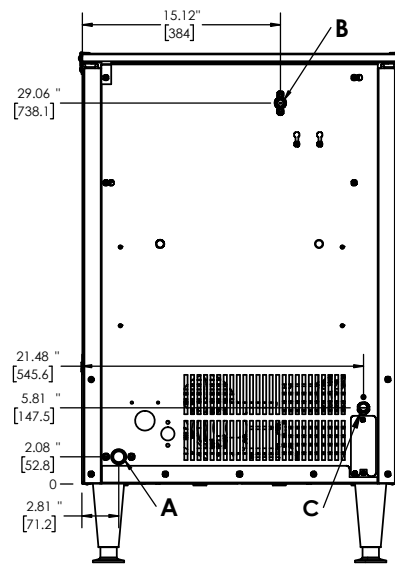

Air Cooled

- A. Ice Maker Drain, 3/4" FPT
- B. Ice Maker Potable Water Inlet, 3/8" FPT
- C. Electrical Connection, 7/8" Hole
(Cord on 115V Models)

SPECIFICATIONS

Model	CIMU220FA90	Ice Production per 24 hrs	
Condensing Type	Air	70° air / 50° water lbs (kg)	90° air / 70° water lbs (kg)
Voltage/Hertz/Phase	115/60/1	220 (100)	167 (76)
Min. Circuit Amp	9.1 A	Water Usage gallons per 100 lbs of ice 90°F air / 70°F water	
Max Breaker Size	15 A		
kWH per 100 lbs of ice at 70°F air / 50°F water	3.7	Potable	Condenser
kWH per 100 lbs of ice at 90°F air / 70°F water	5.82	22.5	N/A
BTU (approx per hour)	2195		
Number of Wires	3 (including ground)		
Refrigerant	R290A		
Refrigeration Charge	80 g		

OPERATING REQUIREMENTS

	MINIMUM	MAXIMUM
Ambient Temp. Range Air	50°F (10°C)	100°F (38°C)
Water Temp	40°F (4°C)	100°F (38°C)
Water Pressure	20 PSIG (1.4 BAR)	60 PSIG (4.1 BAR)

DIMENSIONS

Unit Width	24.54 in.	623 mm
Unit Depth	26.27 in.	667 mm
Unit Height	39 in.	991 mm
Shipping Weight	153 lbs / 69.4 kg	
Shipping Dimensions (in.)	29 (W) x 27 (D) x 39 (H)	
Shipping Dimensions (mm)	736.6 (W) x 685.8 (D) x 990.6 (H)	