

Ice-O-Matic[®]

Ice. Pure and Simple[™]



ELEVATION SERIES CUBE ICE MAKER



CIM Modular Cubers CIM 0320 - CIM 2046

Technical Service Manual

Contents

ELEVATION SERIES CIM CUBERS TABLE OF CONTENTS	2
Installation	5
Electrical and Plumbing Requirements.....	11
Start-Up Procedure	14
Sequence of Operations	15
Control Board.....	29
Board Led Sequence During Operation Test Control Boards.....	32
Sump	41
High and Low Float Switches and Housing	45
Water Pump	49
Water Distribution Tube	50
Water Inlet Valve.....	52
Purge Valve.....	53
Harvest Assist Assembly/Hot Gas Valve.....	54
Magnetic Curtain Switch.....	55
High Pressure Cut-out and Fan Cycle Switch.....	56
Fan Motor.....	57
Evaporator	58
High Temp Safety	67
Refrigeration Section.....	68
Freeze Cycle.....	71
Harvest Cycle.....	72
General Maintenance	73
Cleaning and Sanitizing.....	74
Cabinet Care	76
Winterizing Procedures	77

Wiring Diagram.....	71
CIM 115V and 230V, 60Hz, SINGLE PHASE, SINGLE EVAPORATOR AIR AND WATER COOLED UNITS.....	71
CIM 220V - 240V, 50Hz, SINGLE PHASE, SINGLE EVAPORATOR PLATE AIR AND WATER COOLED UNITS.....	72
CIM 115V and 230V, 60Hz, THREE PHASE, SINGLE EVAPORATOR AIR AND WATER COOLED UNITS.....	73
CIM 115V and 230V, 60Hz, SINGLE PHASE, SINGLE EVAPORATOR PLATE REMOTE COOLED UNITS.....	74
CIM 220V - 240V, 50Hz, SINGLE PHASE, SINGLE EVAPORATOR REMOTE COOLED UNITS.....	75
CIM 230V, 60Hz, THREE PHASE, SINGLE EVAPORATOR PLATE REMOTE COOLED UNITS.....	76
CIM 115V and 230V, 60Hz, SINGLE PHASE, DUAL EVAPORATOR AIR AND WATER COOLED UNITS.....	77
CIM 220V - 240V, 50Hz, SINGLE PHASE, DUAL EVAPORATOR AIR AND WATER COOLED UNITS.....	78
CIM 230V, 60Hz, THREE PHASE, DUAL EVAPORATOR AIR AND WATER COOLED UNITS.....	79
CIM 115V and 230V, 60Hz, SINGLE PHASE, DUAL EVAPORATOR REMOTE COOLED UNITS.....	80
CIM 220V - 240V, 50Hz, SINGLE PHASE, DUAL EVAPORATOR REMOTE COOLED UNITS.....	81
CIM 230V, 60Hz, THREE PHASE, DUAL EVAPORATOR REMOTE COOLED UNITS.....	82

Introduction

Energy Efficiency

Ice-O-Matic has partnered with ENERGY STAR since 2004 to ensure our customers receive the most efficient ice machines for your investment dollar. Ice-O-Matic is committed to the continuous improvement in both energy efficiency and productivity thereby delivering the best value in energy efficient ice machines money can buy.

For a detailed list of ENERGY STAR qualified Ice-O-Matic ice machines, go to:

<http://www.iceomatic.com/Products/Sales-Literature/#>

Freight Claims

Inspect Promptly

This merchandise has been carefully inspected and packed in accordance with the carrier's packing specifications. Responsibility for safe delivery has been assumed by the carrier. If loss or damage occurs, you as the consignee must file a claim with the carrier and hold the container for carrier's inspection.

Visible Loss or Damage

Any external evidence of loss or damage must be fully described and noted on your freight bill or express receipt and signed by the carrier's agent. The claim should be filed on a form available from the carrier.

Concealed Loss or Damage

If loss or damage does not appear until merchandise has been unpacked, make a written request for inspection by the carrier within 5 days of the delivery date, then file a claim on a form from the carrier.

FILE CLAIMS WITHOUT DELAY

**DO NOT RETURN DAMAGED GOODS
TO ICE-O-MATIC**

How to use this Manual

Ice-O-Matic provides this manual as an aid to the Refrigeration Service Technician for installation and maintenance of the CIM cube ice machines. Do not attempt to perform installation, start-up or maintenance unless you have read and fully understand this manual.

Ice-O-Matic icemakers and dispensers are not approved for outdoor installation.

CIM Cubers contain R404A Refrigerant, R449A Refrigerant, or R290 Refrigerant.

To find a Service Provider, please reference our “Find a Service Technician” tab at www.iceomatic.com

Keep this manual for future reference.

The CIM Series Service Parts Manuals are available separately.



WARNING

Always disconnect electrical power and shut off water supply whenever maintenance or repairs are performed on the ice machine and related equipment.

CAUTION

Always wear protective eye wear whenever maintenance or repairs are performed on the ice machine and related equipment.

Ice-O-Matic Warranty

Every Ice-O-Matic ice maker is backed by a warranty that provides both parts and labor coverage. To view the warranty details, register products, or check your warranty status visit the “Warranty and Water Filter Registration” page on www.iceomatic.com

Model And Serial Number Format

Model Numbers

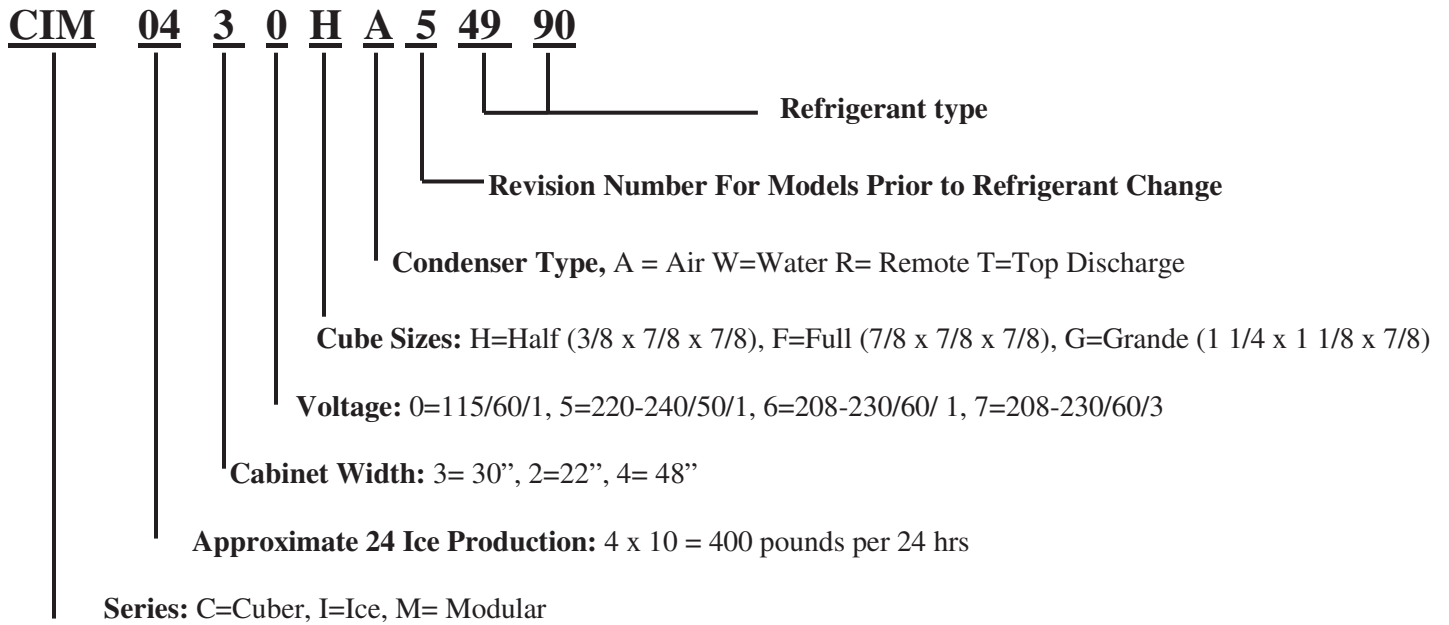

Serial Number

The format for the Serial Number is 14 characters long and begins with a date code followed by the Ice-O-Matic identifier, and then a sequential number. This is an entirely numerical serial number.

2508 12800 12345

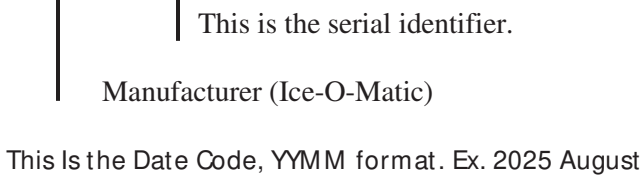

Each serial number provides essential information not only about production dates and manufacturer but also serves as a key for tracing unit specifications and service history. Accurate identification remains vital, especially as we move toward new refrigerant standards and labeling requirements

REFRIGERANT CHANGES

In compliance with EPA regulations requiring the transition away from R-404A refrigerant, effective January 1, 2026, we are updating the refrigerants used in our units to more environmentally sustainable options. Larger remote units will utilize R449A refrigerant, while self-contained units will operate with R-290 refrigerant. Identification of these units will be facilitated through multiple indicators: the final two digits of the model number (as referenced on the preceding page), the data tag, and stickers affixed to line-sets. Additionally, R-290 units will feature specific warning labels as detailed below.

R449 refrigerant possesses characteristics closely resembling those of R-404A, requiring minimal modifications to existing units aside from a TXV replacement.

In contrast, R-290 exhibits distinct properties that necessitate different considerations.

What is R290?

R290 is Propane

- Extremely Pure
- Highly Flammable
- **NO ADDED ODORANT** (no smell)
- Heavier than air (pools up in low areas)

R290 SAFETY HAZARDS

Fire/Explosion



Asphyxiation

- You cannot get enough air to breath – there's not enough oxygen
- R404 and R449 are also asphyxiants



Installation Guidelines

For proper operation of the ice machine, the following installation guidelines must be followed by a **Qualified Refrigeration Technician**. Failure to do so may result in loss of production capacity, premature part failures, and may **void all warranties**.

Reference the installation parameters prior to installing the machine. Ice-O-Matic assumes no responsibility for improperly installed equipment. **Excessive time required for service or time for units requiring removal for service of inaccessible equipment will be the sole responsibility of the equipment owner.**

Ambient Operating Temperature

Minimum operating temperature:

Air cooled units 50°F (10°C)

Remote units -20°F (- 29°C)

Maximum operating temperature:

Air cooled Units 100°F (38°C) (60 Hz.), 110°F (43°C) (50 Hz.).

Remote units 120° F (49°C)

Note: Ice-O-Matic ice-makers and dispensers are not approved for outdoor installation

Incoming Water Supply

WARNING: Connect to unheated potable water supply only!

(See Electrical and Plumbing diagrams for line sizing)

Minimum incoming water temperature: 40°F (4.5°C)

Maximum incoming water temperature: 100°F (38°C)

Minimum incoming water pressure: 20 psi (1.4 bar, 0.138MPa)

Maximum incoming water pressure: 80 psi (5.5 bar, 0.552MPa)

Note: if water pressure exceeds 80 psi (5.5 bar), a water pressure regulator must be installed

All water supply lines must be installed per local codes. Use 3/8 inch O.D. minimum on air cooled machines. On water cooled machines 3/8 inch O.D. minimum tubing must be run to the condenser. The water supply for the machine can “T” off from the condenser line using 3/8 inch O.D. minimum tubing. Make 2 coils of extra tubing so that the machine can be pulled away from the wall if service is needed.

Water Filtration/Treatment

A water filter system should be installed with the ice machine. Refer to Ice-O-Matic water filter specification sheet.

Reverse Osmosis (RO) water can be very acidic and can attack the evaporator and other metal in the ice machine. Because the RO process removes all minerals and metals from the water it can promote the faster growth of microbial mold and slime. If RO water is used, Ice-O-Matic recommends the water pH verified to be a neutral 7.0 to minimize the corrosive effects. Incorrect cleaners, sanitizers, and RO water that does not have a neutral pH could **void the machine’s warranty**.

Drains

All drain lines must be installed per local codes. Flexible tubing is not recommended. Route bin drain, purge drain and water condenser drain individually to a floor drain. The use of condensate pumps for draining water is not recommended.

Ice-O-Matic assumes no responsibility for improperly installed equipment. This may void the warranty.

**Note: The Purge Drain Fitting is plastic: DO NOT apply heat to the purge drain area;
DO NOT over-tighten drain connection.**

The purge drain should be a minimum of 3/4 inch O.D. tubing, and properly vented. The condenser drain on water cooled units should be 1/2 inch O.D. minimum. The drain line fittings on Ice-O-Matic bins are 3/4 FPT. The bin drain should be a minimum of 3/4 inch O.D. and properly vented. Cold water drains should be insulated to prevent condensation from forming.

It is not recommended that a Drain pump be used on CIM Model Ice machines

Clearance Requirements

Self-contained air-cooled ice machines should have a minimum of 6 inches (15cm) of clearance at the rear, top and sides for proper air circulation and adequate space for serviceability.

Self-contained air-cooled ice machines exhaust air out the top and right side. There are two alternative air exhaust options. Option A (top exhaust bias): minimum of 6 inches (15cm) of clearance at the rear and top of the ice machine for proper function at maximum operating conditions. Option B (side exhaust bias): minimum of 6 inches (15cm) of clearance at the rear and right side of the ice machine with a minimum of 3 inches (7.5cm) of clearance at the top for proper function at maximum operating conditions.

CAUTION: Improper ventilation will cause unit to Malfunction and Service will not be covered under Warranty

Appropriate space should be allowed for proper serviceability of the machine.

Excess time to gain access for serviceability is not covered under warranty.

Stacking

Ice-O-Matic does not endorse stacking ice machines.

Dispenser Application

A thermostatic bin control kit is required when installing the CIM Cube ice machine on a dispenser. The use of a bin top depends on the application and should be secured to the dispenser accordingly.

Electrical Specifications

Check the serial plate at the rear of the ice machine to verify correct voltage and circuit breaker size. The ice machine should operate on a dedicated circuit. For European installations, the electrical supply fixed wiring must have a disconnect mechanism with at least 3mm separation in all poles.

These ice machines do not include an electrical cord set and are designed for permanent connection as approved by relevant agencies.

Units are not approved for GFI outlets. Electrical connections or cord installation must be performed by a qualified electrician to prevent electrical hazards.

Adjustments

- Level the machine within 1/8 inch in all directions.
- Inspect the water in the Water Sump to confirm proper level.
- Evaluate the ice bridge thickness and adjust the Float Switch Housing Assembly as necessary.
- If water cooled, check the Water Regulating Valve adjustment.

Note: These adjustments should be completed by a Qualified Service Technician during unit installation; they are not covered under factory warranty.

Secure the ice machine onto the bin or dispenser using mounting straps provided. Ensure the back of the ice machine aligns flush with the bin's back. For proper operation, the Bin Door should remain stable when open. Installing the ice machine too far forward may lead to instability, causing the door to close unexpectedly.

When mounting on bins or dispensers not manufactured by Ice-O-Matic, refer to the manufacturer's installation instructions. Ice-O-Matic does not accept responsibility for damage or injury resulting from improper placement that causes the bin door to close unexpectedly.

Remote Condenser Installation

For proper operation of the ice machine, the following installation guidelines must be followed. Failure to do so may result in loss of production capacity, premature part failure, and may **void all warranties**.

Use the following for planning the placement of the remote condenser relative to the ice machine

Location Limits

Remote condenser location must not exceed **ANY** of the following:

The maximum rise from the ice machine to the remote condenser is 35 physical feet.

The maximum drop from the ice machine to the remote condenser is 10 physical feet.

The physical line set maximum length is 75 ft.

The calculated line set maximum length is 100 ft.

Ambient operating temperatures:

-20°F (-28.9°C) to 120°F (48.9°C)

Limitations on line-set runs

Maximum Rise is 35'

Maximum Drop is 10'

Maximum Run Is 100'

Formula for calculating Maximum run is as follows.

Formula for calculating Maximum run is as follows.

RISE

Rise x 1.7 + Horizontal Run = < 100'

Example: 35' x 1.7 + 40' = 99.5' this is < 100 so it is ok.

NOT TO EXCEED 100 CALCULATED FEET

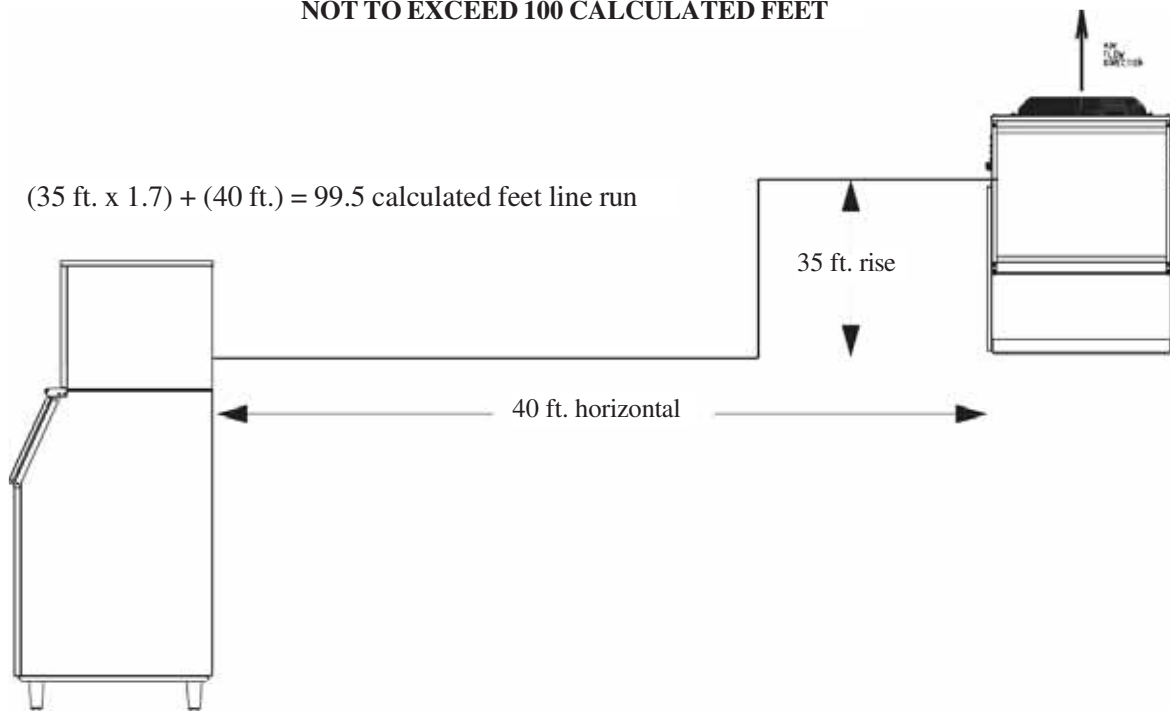

Drop:

$(10 \text{ ft.} \times 6.6) + (34 \text{ ft.}) = 100$ calculated feet line run

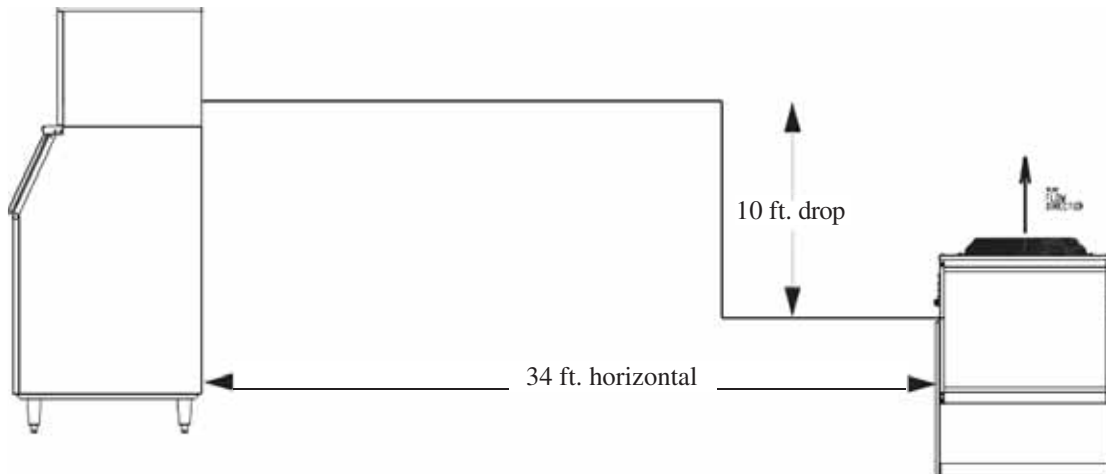

Example: $10' \times 6.6 + 30' = 90'$ This is < 100 so it is ok.

Configurations that do NOT meet these requirements must receive written authorization from Ice-O-Matic. This includes multi-pass or rack system remote condensers.

Remote Condenser Location

Pre-charged line sets are available in 25-, 40- or 75-foot lengths to connect the ice machine to the remote condenser. Select the best available location, protecting the remote condenser from extremes of dirt, dust and sun. Meet all applicable building codes. The services of a licensed electrician may be required. Clearances required for the RCA/RGA Condensers are 48" above and 18" on all side of the unit for proper air flow.

Roof Attachment

Install and attach the remote condenser to the roof of the building using the methods and practices of construction that conform to the local building codes, including having a roofing contractor secure the remote condenser to the roof.

Have an electrician connect the remote condenser fan motor wires to the ice machine using the junction box at the back of the machine.

NOTE: REMOTE LINES MUST NOT RISE AND DROP IN THE SAME RUN

Have a roofing contractor cut a minimum hole for the refrigerant lines of 2.50 inch. Check local codes, a separate hole may be required for the electrical power to the condenser.

CAUTION: DO NOT KINK OR CRIMP REFRIGERANT TUBING WHEN INSTALLING IT.

Pre-charged Line Set Routing

CAUTION: Do not connect the pre-charged tubing until all routing and forming of the tubing has been completed. See the coupling instructions for connecting information.

Each set of pre-charged tubing refrigerant lines consists of a 3/8" diameter liquid line and 1/2-inch diameter discharge line. Both ends of each line have quick connect couplings, one end of the line set has a Schrader valve connection.

Route refrigerant lines through the roof opening in straight paths when possible. Keep excess tubing inside the building, spiraling it horizontally to prevent traps. Ensure the roofing contractor seals roof holes according to local codes.

CAUTION: The couplings on the sets of pre-charged lines are self-sealing when installed properly. Carefully follow the instructions in the Remote Condenser manual.

Verify all remote components and refrigerant types match before connecting line-sets. Mixing refrigerants voids the warranty and any related repairs will not be covered.

The following remote ice makers incorporate the Mixing Valve in the Condenser. This configuration allows up to a 100-foot calculated remote line set run. Reference the diagram on the Previous pages to calculate the maximum 100 ft. line set run. Maximum **actual line set run** is limited to 75ft.

CIM Machine Model Number	Remote Condenser Model Number Old/New
CIM0530R	RCA1001/RC100C40/49
CIM0535R	RCA1061/RC106C40/49
CIM0636R	RCA1061/RC106C40/49
CIM0825R/0826R/0835R/0836R/0837R	RCA2061/RC206C40/49
CIM1125R/1126R/1135R/1136R/1137R	RCA2061/RC206C40/49
CIM1446R/1447R	RCA3061/RC306C40/49
CIM1545R/1845R	RCA3061/RC306C40/49
CIM2046R/2047R	RCA3561/RC406C40/49

**Verify the CIM machine is compatible with the remote condenser.
For more information contact your Ice-O-Matic distributor.**

Electrical and Plumbing Requirements

22" CIM SERIES Common Connections (CIM**2* A)

Air Cooled

Please note: air-cooled units require 6" (152mm) for air intake and exhaust.

- A. Ice maker potable water in, 3/8" FPT.
- B. Ice maker water out, 3/4" FPT.
- C. Hole for electrical connections, 7/8".
- D. Electrical junction box, 7/8".

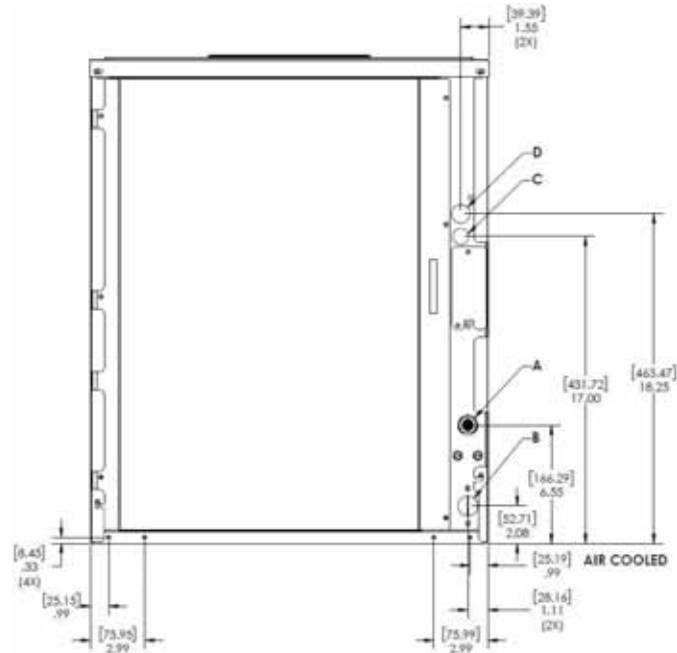

(CIM**2* W/R)

Water/Remote Cooled

- A. Ice maker potable water in, 3/8" FPT.
- B. Ice maker water out, 3/4" FPT.
- C. Hole for electrical connections, 7/8".
- D. Electrical junction box, 7/8" (remote).
- E. Condenser water in, 3/8" FPT (water only).
Discharge line, 1/2" male quick connect coupling for pre-charged line set (remote only).
- F. Condenser water out, 1/2" FPT (water only).
- G. Liquid Line, 3/8" male quick connect coupling for pre-charged line set (remote only).

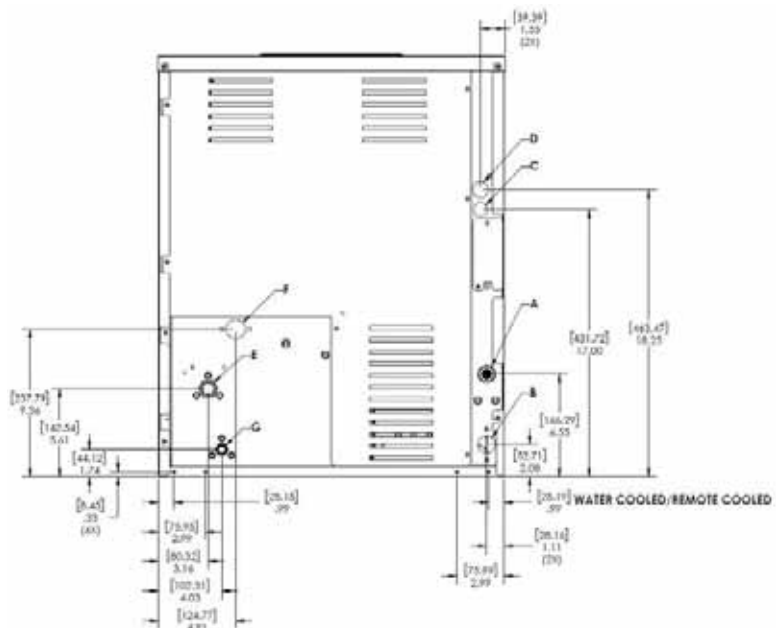

30" CIM SERIES Common Connections (CIM**3* A)

Air Cooled

Please note: air-cooled units require 6"(152mm) for air intake and exhaust.

- A. Ice maker potable water in, 3/8" FPT.
- B. Ice maker water out, 3/4" FPT.
- C. Hole for electrical connections, 7/8".
- D. Electrical junction box, 7/8".

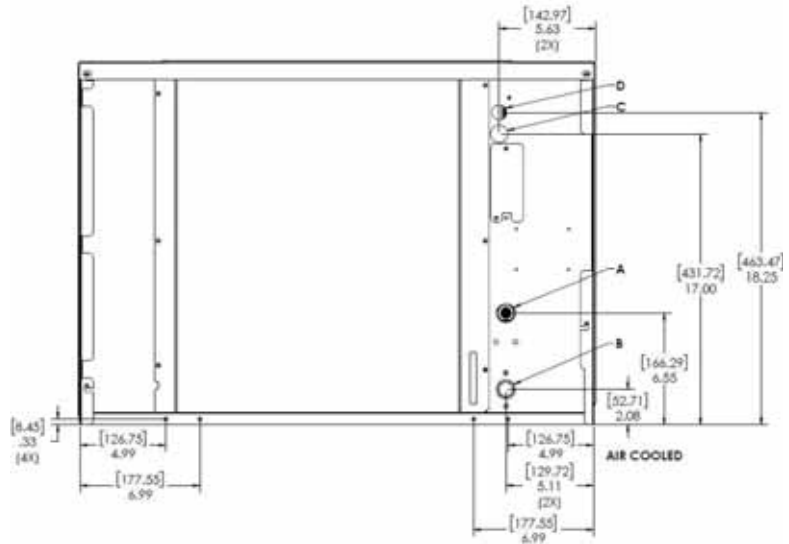

(CIM**3* W/R)

Water/Remote Cooled

- A. Ice maker potable water in, 3/8" FPT.
- B. Ice maker water out, 3/4" FPT.
- C. Hole for electrical connections, 7/8".
- D. Electrical junction box, 7/8" (remote).
- E. Condenser water in, 3/8" FPT (water only). Discharge line, 1/2" male quick connect coupling for pre-charged line set (remote only).
- F. Condenser water out, 1/2" FPT (water only).
- G. Liquid Line, 3/8" male quick connect coupling for pre-charged line set (remote only).

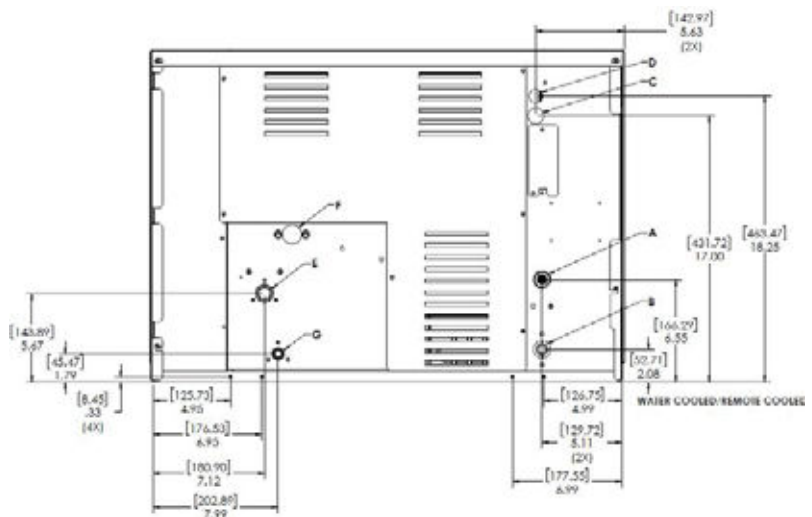

48" CIM SERIES Common Connections (CIM**4* A)

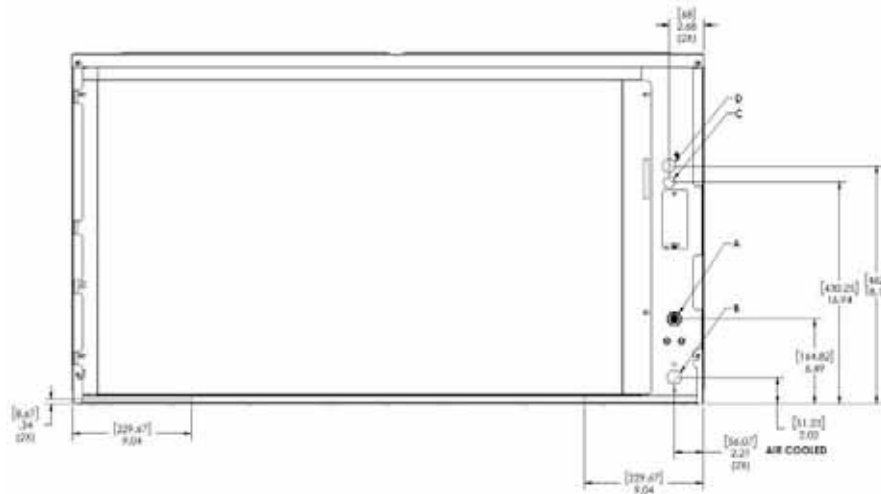

Please note: air-cooled units require 6"(152mm) for air intake and exhaust.

- | | |
|---|--|
| <ul style="list-style-type: none"> A. Ice maker potable water in, 3/8" FPT. B. Ice maker water out, 3/4" FPT. | <ul style="list-style-type: none"> C. Hole for electrical connections, 7/8". D. Electrical junction box, 7/8". |
|---|--|

(CIM**4* W/R)

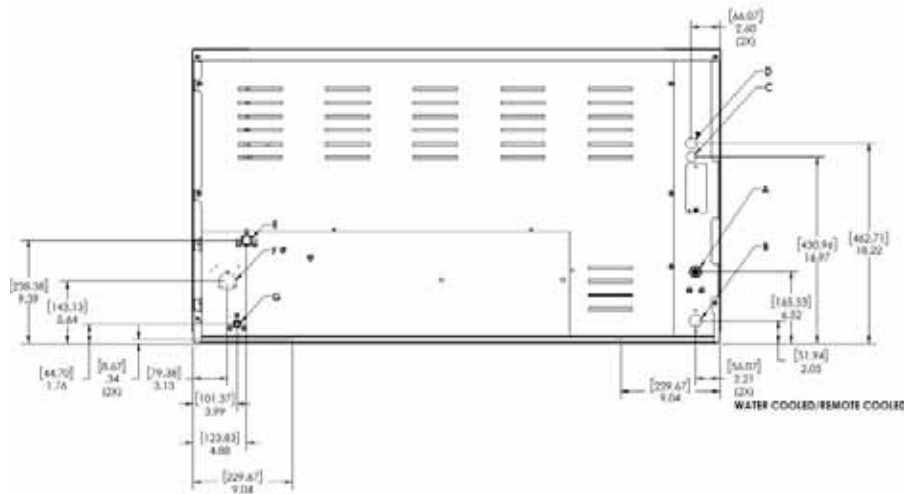

Water/Remote Cooled

- | | |
|--|--|
| <ul style="list-style-type: none"> A. Ice maker potable water in, 3/8" FPT. B. Ice maker water out, 3/4" FPT. C. Hole for electrical connections, 7/8". D. Electrical junction box, 7/8" (remote). | <ul style="list-style-type: none"> E. Condenser water in, 3/8" FPT (water only). Discharge line, 1/2" male quick connect coupling for pre-charged line set (remote only). F. Condenser water out, 3/4" FPT (water only). G. Liquid Line, 3/8" male quick connect coupling for pre-charged line set (remote only). |
|--|--|

Start-Up Procedure

Note: Before starting the machine, make sure the machine is level within 1/8 inch in all directions, the bin or dispenser leg height can be adjusted by rotating the leg foot

After verifying proper voltage, water supply, drains and breathable air space around the unit, press and quickly release the ON/OFF button behind the unit front panel. The indicator light will change from a solid red to solid blue in color.

Follow the sequence of operation described under “Operation of CIM Series Cuber” in this manual. Check the operation of each component through the cycle as explained in this section.



Access to Water Level Adjustment

Bridge Thickness Adjustment

Once the unit has gone through a harvest cycle, verify the bridge thickness (3/16” thick for units less than 400 lbs. and 1/8” for 400 lbs. and above) across the middle of the ice slab on the second batch produced. The ice thickness can be changed on the Float Housing by turning the adjustment clockwise to decrease the bridge thickness and counterclockwise to increase the bridge thickness. You will hear a “click” with each adjustment. It is recommended adjustments be made one or two “clicks” at a time.



Raising lever increases bridge thickness

Lowering lever decreases bridge thickness

Batch weights for each model

Model	Batch Weight		
	Half Cube	Full Cube	Grande Cube
CIM0320/0330	2.9-3.15	3.25-3.5	-
CIM0430/0520/0530/0636	4.9-5.15	5.5-5.8	-
CIM0826/0836/1126/1136	6.9-7.4	7.9-8.3	8.4-8.8
CIM1446/1545/2046/2047	13.8-14.8	15.8-16.6	-

Sequence of Operations

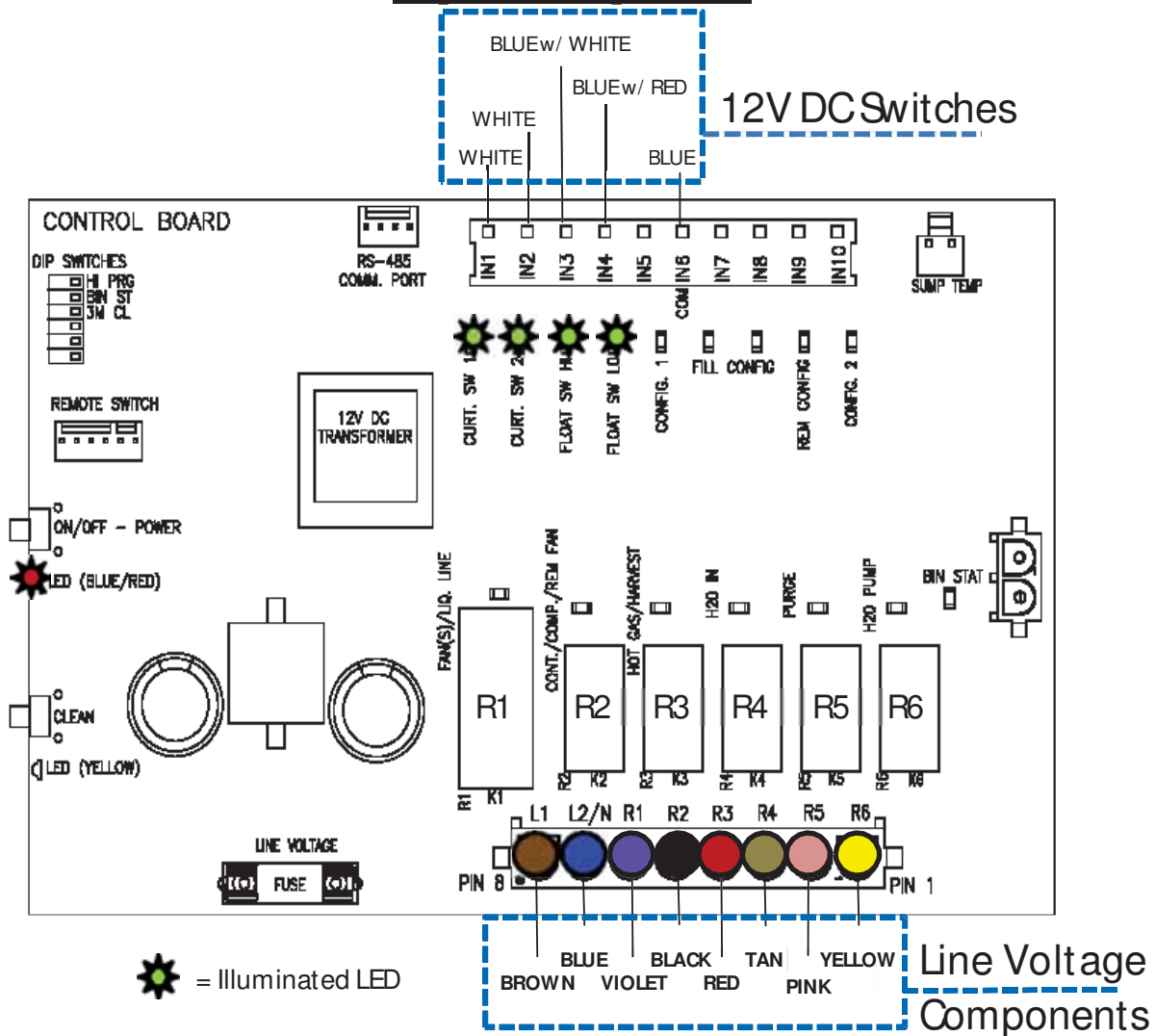

CONTROL BOARD - OFF STATUS

When power is initially applied to the unit, the LED's on both the Push Pad and the Board POWER Button will flash in sequence BLUE, then RED, then the WASH Button will flash YELLOW, followed by the POWER Button LED will turn a solid RED, indicating the unit is in the OFF status as shown above.

The LEDs for the Curtain Switches (1 & 2), High Float Switch and Low Float Switch will be illuminated Indicating closed circuits. Should the Curtains or Bin Thermostat (if installed) be open, the unit will not start a Freeze Cycle.

From an OFF status, the unit can start a CLEAN cycle, a FREEZE cycle or be put in the DIAGNOSTIC mode. For Cleaning Instructions, see page 56. For more on the DIAGNOSTIC mode see page 36.

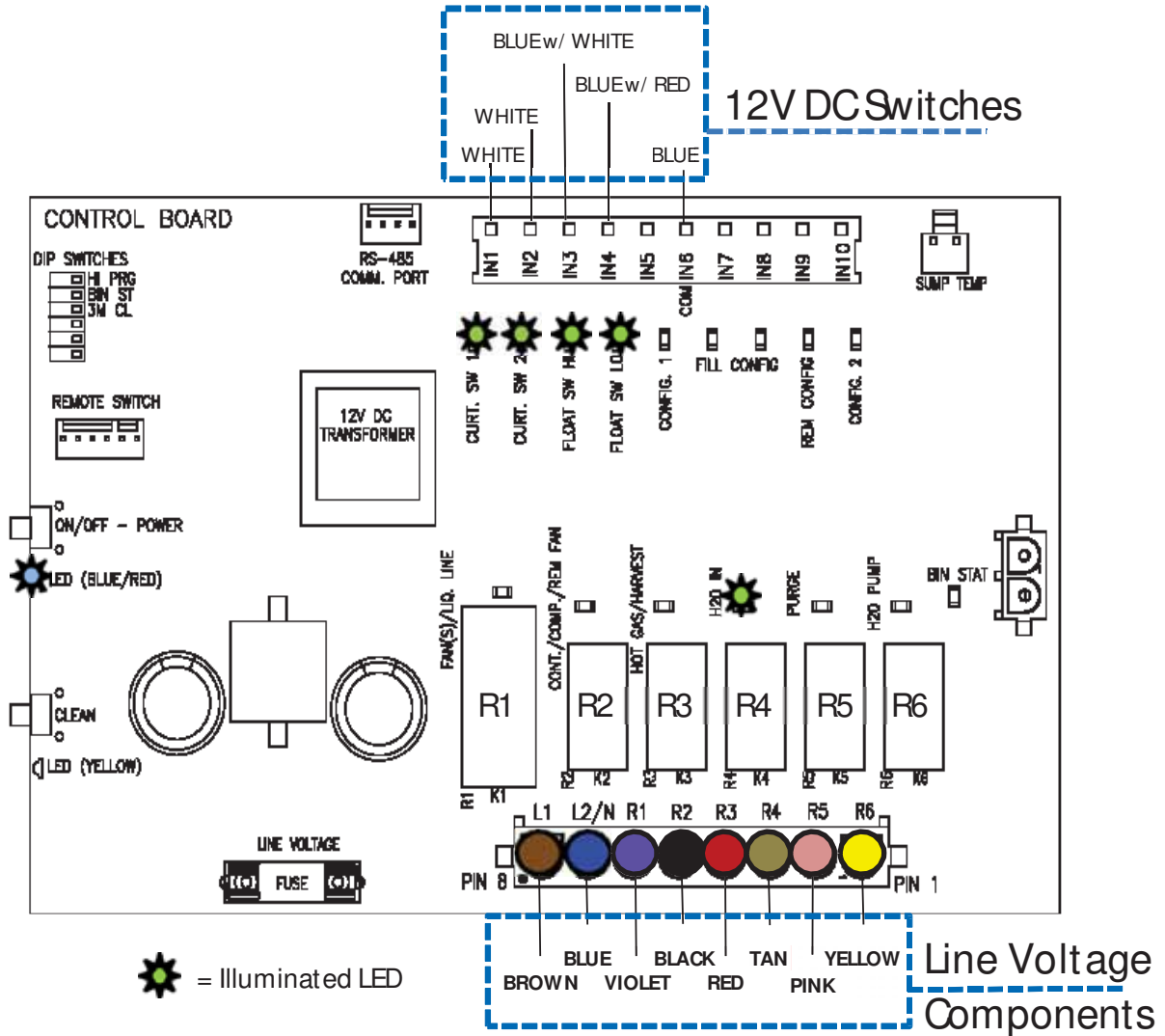

CONTROL BOARD - FREEZE CYCLE

To start the Freeze cycle, briefly press the POWER button on the Membrane Switch or Board. This opens the Water Inlet Valve (shown by the R4 LED), letting water flow into the Sump. As the water rises, the Low-Water Float opens and turns off its Switch LED, and when the High-Water Float opens also turns off its LED, the Water Inlet Valve closes, and the R4 LED goes off.

- Note: Minimum Freeze Cycle - 5 minutes (from Compressor Start.)
- Maximum Freeze Cycle - 1 hour.
- Maximum fill time- 5 minutes

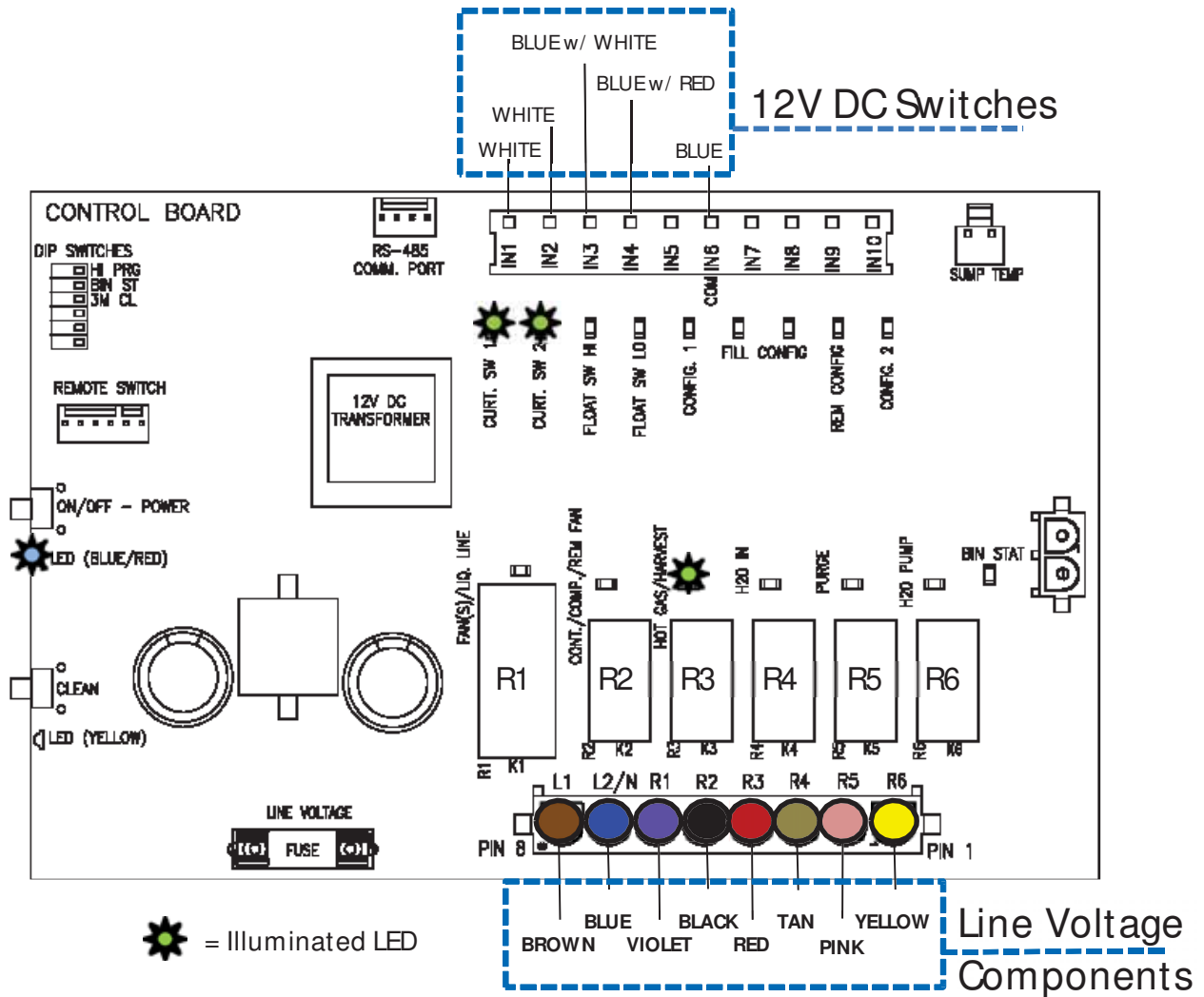

CONTROL BOARD - COM PRESSOR START

The Hot Gas Valve will be energized (R3 on Board illuminated) for 5 seconds and the system pressures will start to equalize.

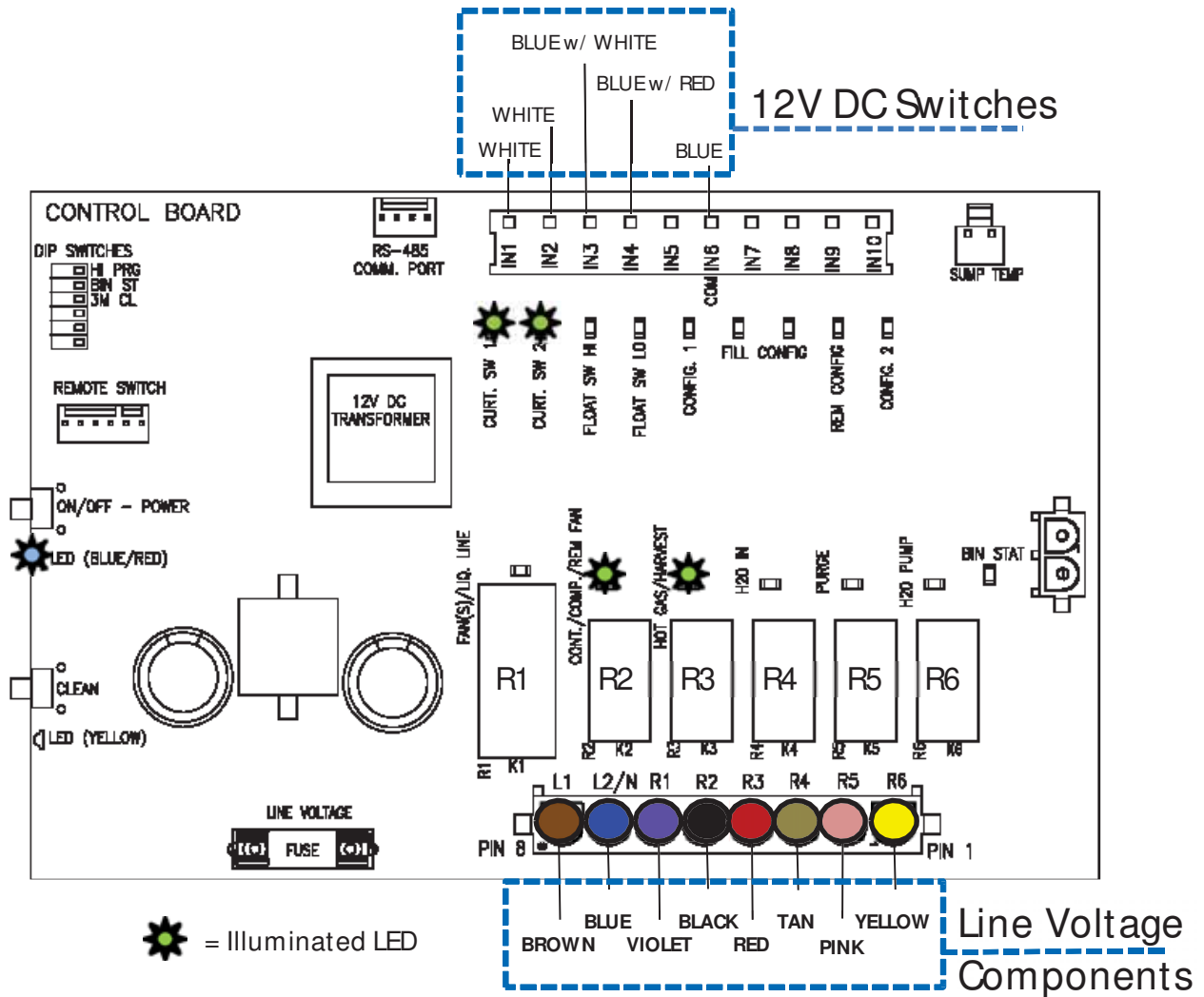

CONTROL BOARD - COM PRESSOR START

The Compressor will be energized (R2 on Board illuminated) and the Hot Gas Valve will remain open for 5 more seconds and then de-energize (R3 on Board off).

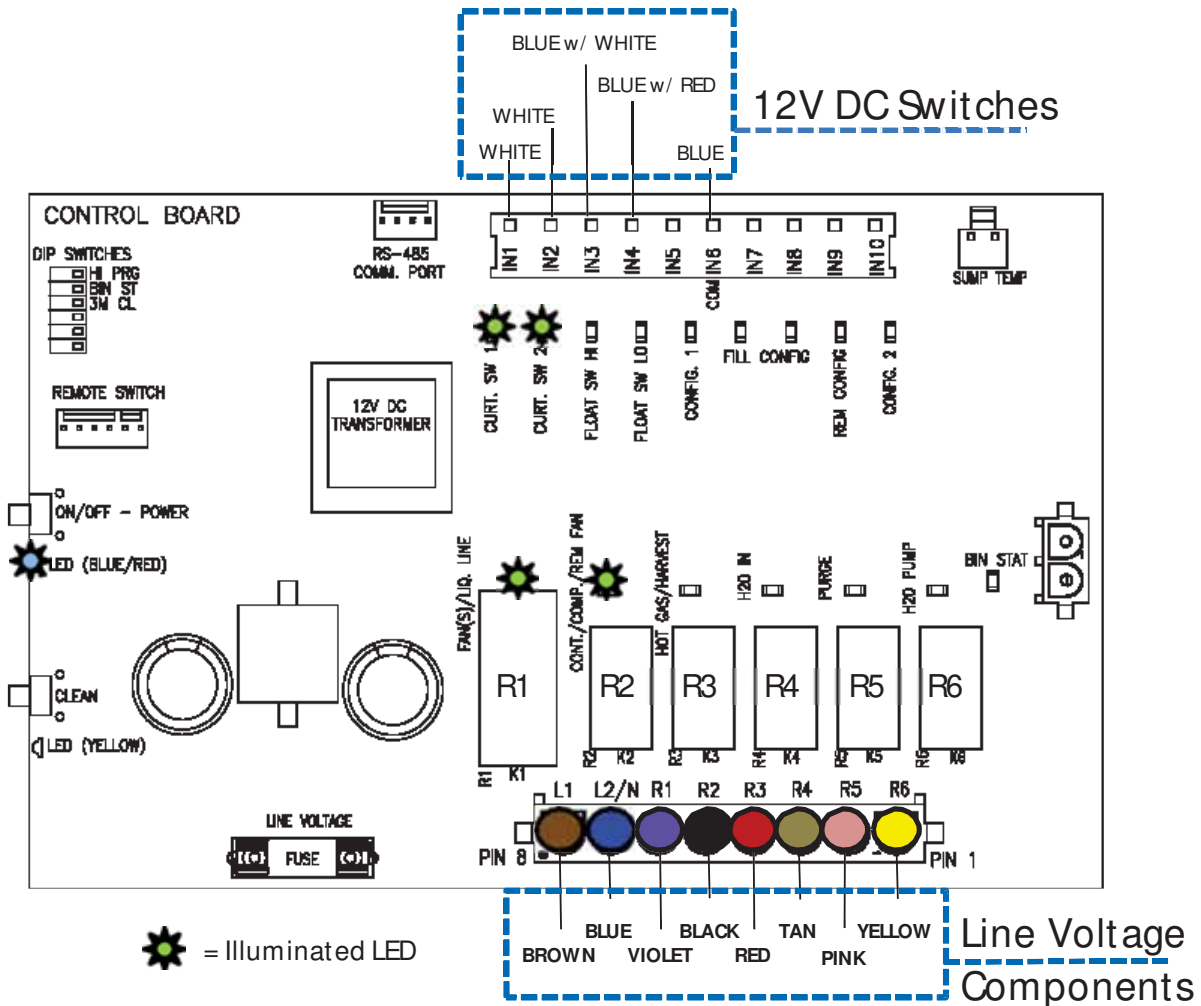

CONTROL BOARD - PRE-CHILL

The Compressor and Fan(s)/ Liquid Line Solenoid (R1 and R2 LEDs on Board illuminated) are energized and unit is now in a Pre-Chill for 30 seconds bringing the Evaporator temperature down. Both Curtain Switch LEDs are on showing closed curtain(s). On the Self-contained units, (R1) is energized the Fan Motor will only come on once the Fan Cycle Switch closes at 250 psi of head pressure. (if fan cycle switch is not bypassed.)

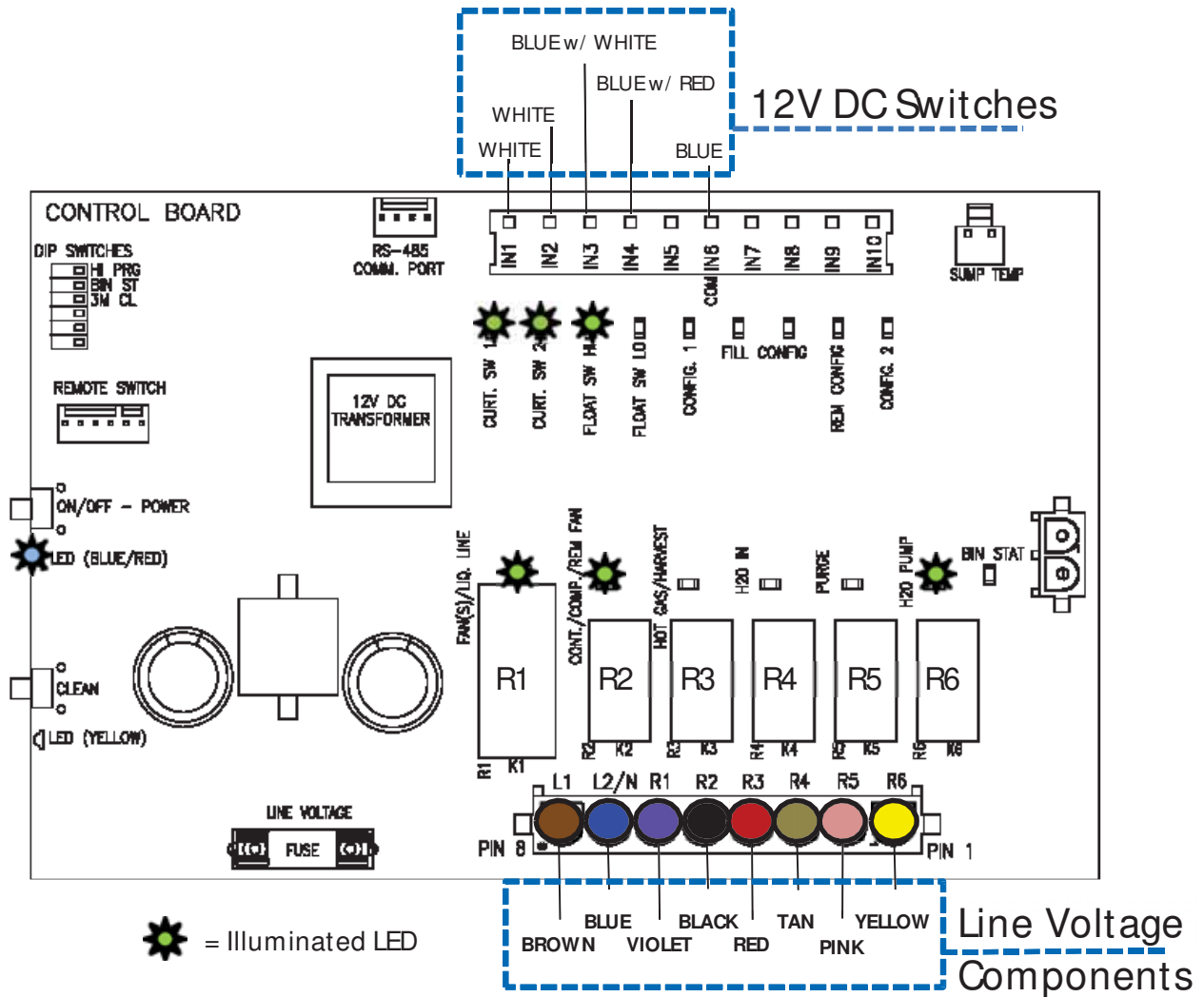

CONTROL BOARD - FREEZE

The Water Pump is energized (R6 LED on Board illuminated) and water is pushed through the Water Pump Tube and flows over the Evaporator. The High Float Switch contacts close as the water level in the Sump drops (High Float Switch LED on Board illuminates). Should this not happen Error 7 will occur.

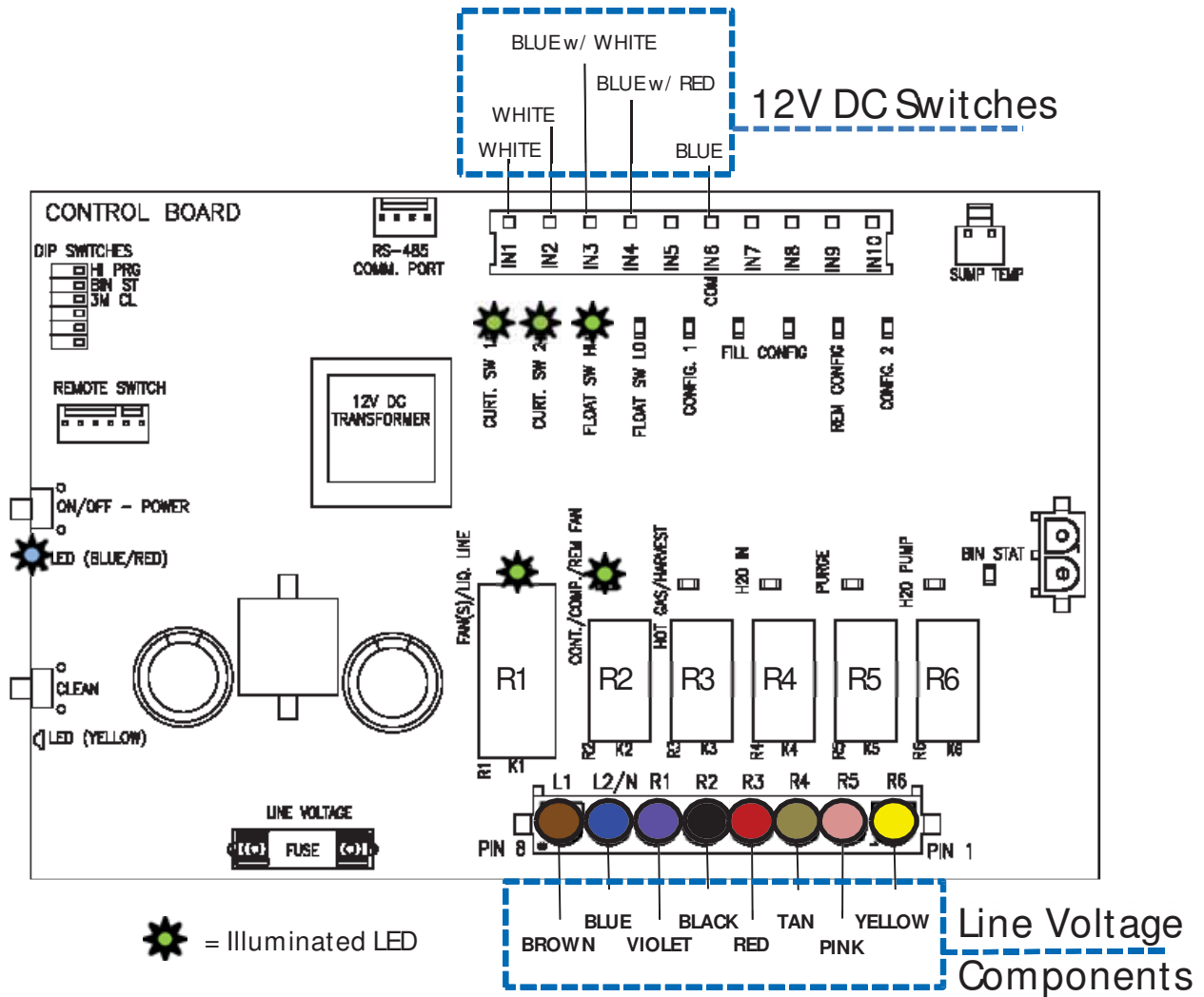

CONTROL BOARD - ANTI-SLUSH

When the water temperature reaches 38 degrees F. the Water Pump will shut off for 20 seconds to reduce the possibility of slush developing in the Sump.

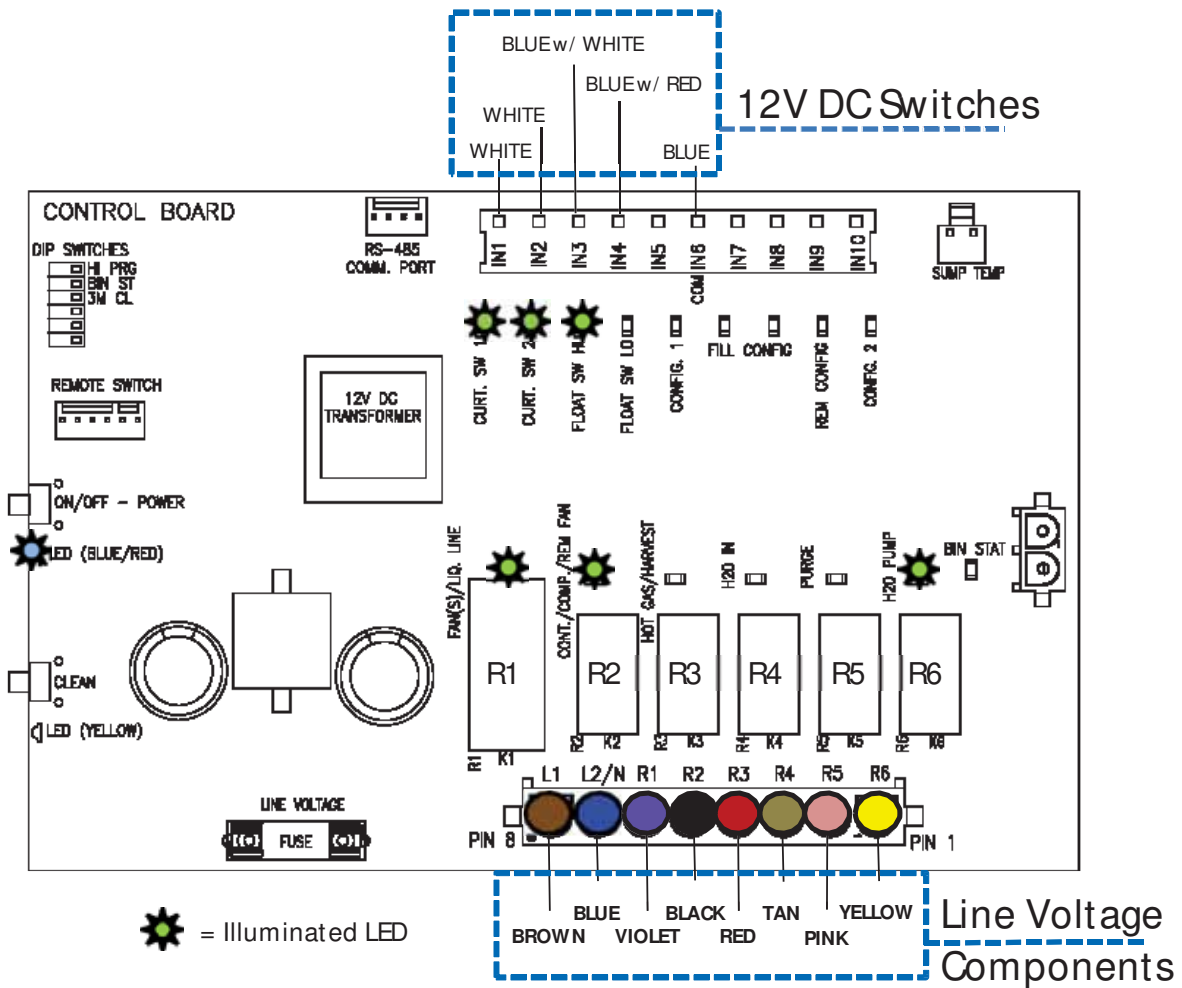

CONTROL BOARD - WATER PUM P ON

At the end of Anti-Slush, the Water Pump (R6) will be re-energized, and water starts flowing over the Evaporator again continuing Freeze mode. The unit will stay in Freeze mode (minimum of 5 min) until the Low Float Switch closes on water level drop (units below 800lbs), or after the second fill on units over 800lbs indicating the unit is ready to harvest.

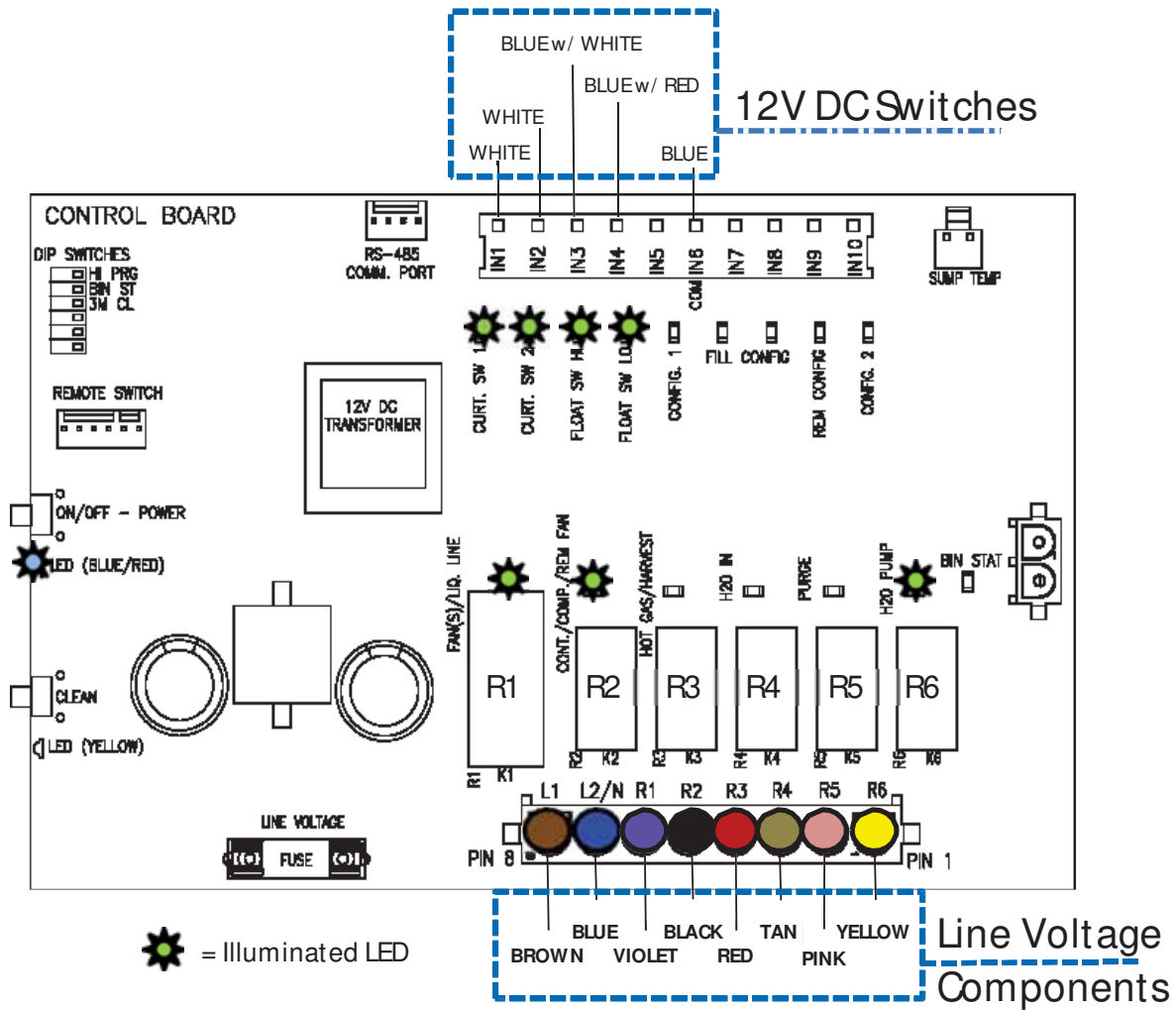

CONTROL BOARD - INITIATING HARVEST

When the water level in the SUMP drops to close the contacts of the Low Float Switch (LED on Board illuminates) after a 5 second Delay of the Low float switch closing it will signal the start of the Harvest Cycle.

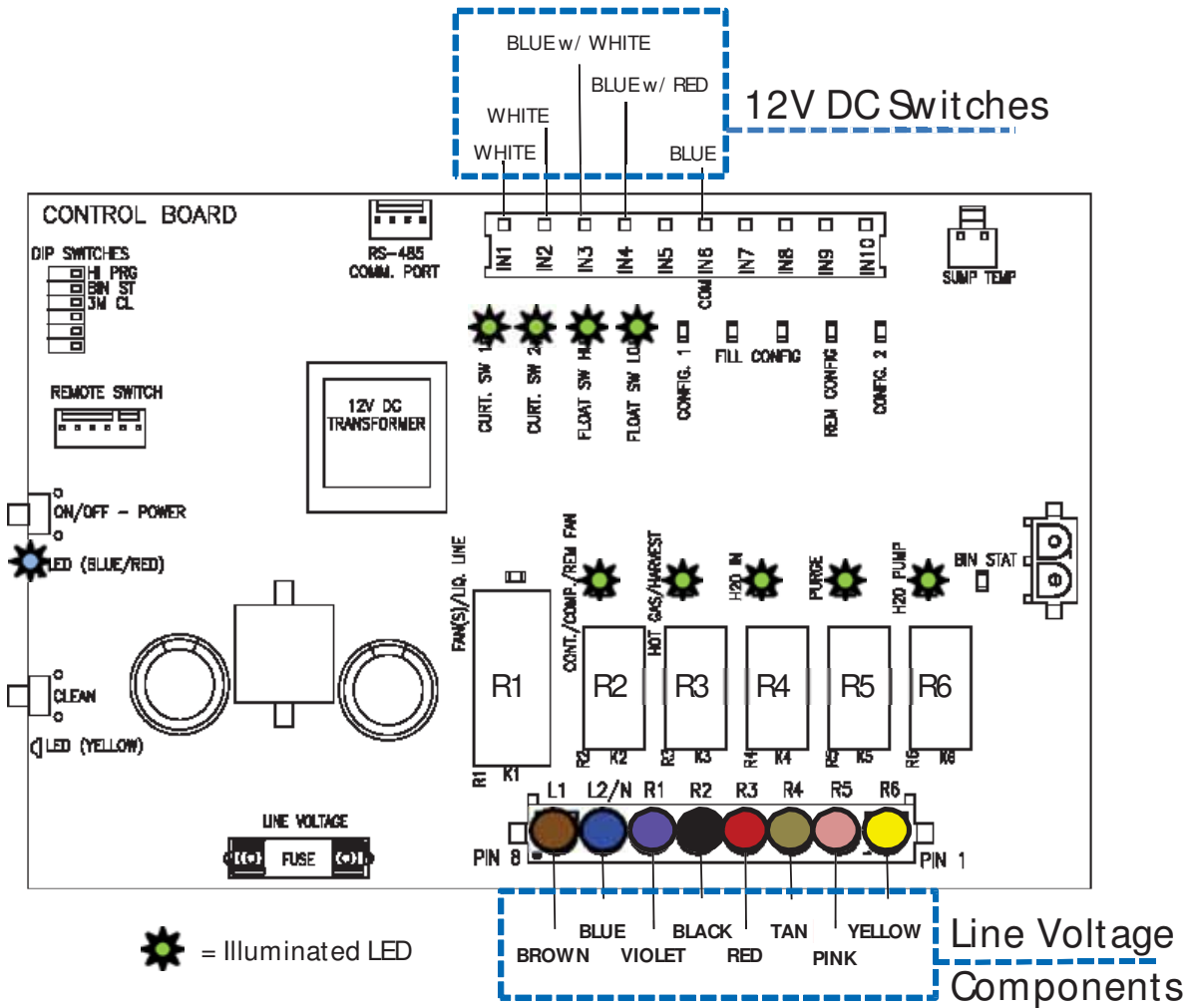

CONTROL BOARD - HARVEST

Once in the Harvest, the R2-R6 relays send power to the Hot Gas Valve, Harvest Assist, Purge Valve, and Water Inlet Valve (R2, R3, R4, R5, and R6 are illuminated on Air- and Water-Cooled units; all relays are energized on Remote units).

CONTROL BOARDS (after Jan 2023)

If the Harvest Time reaches 5 minutes, the Water Pump activates to assist in the harvest process.

NOTE: Minimum harvest time is 20 seconds.

Pre serial number 2106 control boards have a 5 min maximum harvest time.

Post serial number 2106 control boards The maximum harvest time is 7.5 minutes.

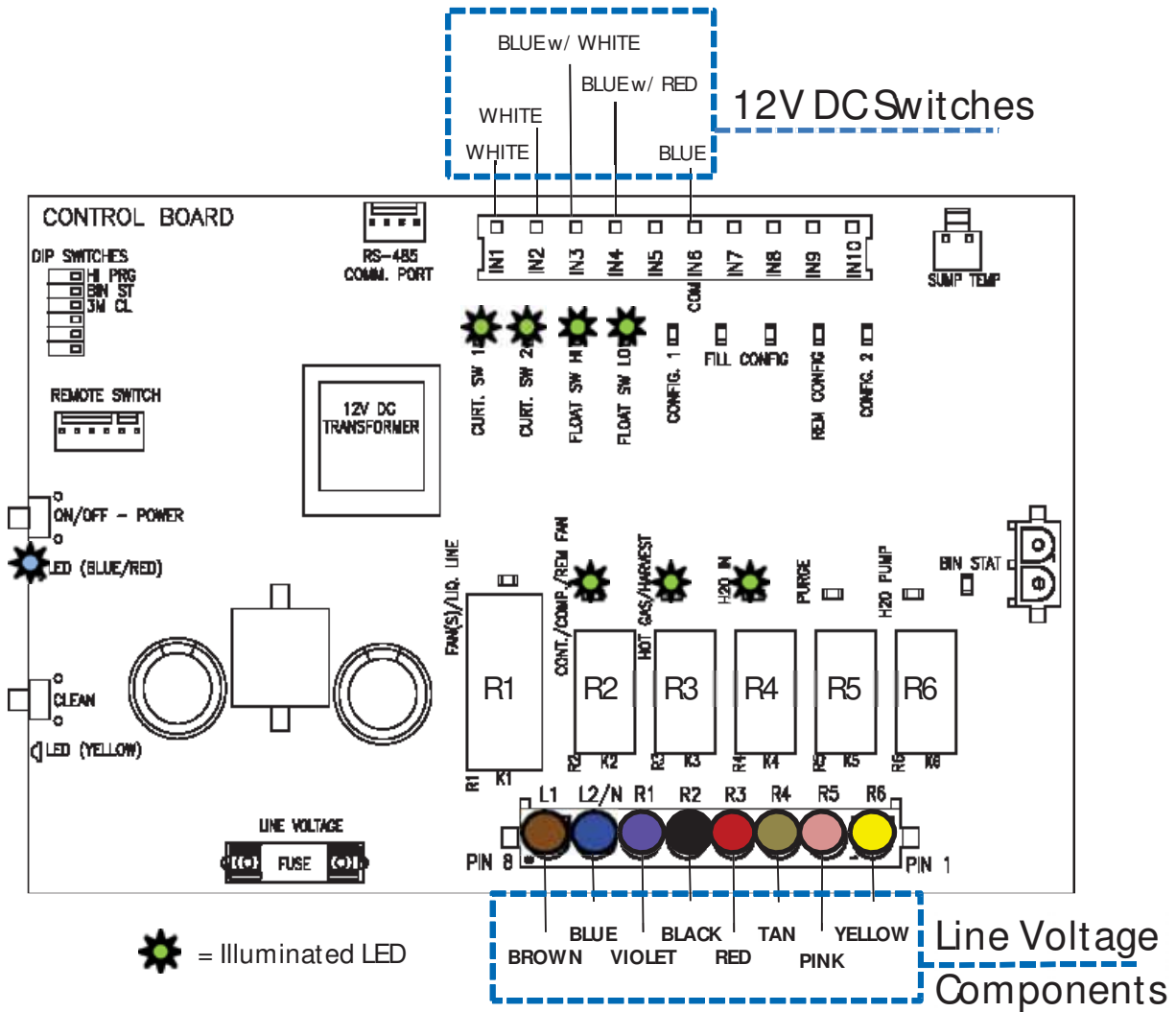

CONTROL BOARD - HARVEST

After the Purge Valve and Water Pump de-energize, the Water Inlet Valve will remain open for 20 seconds partially filling the SUMP in preparation for the next Freeze Cycle (R2, R3, and R4, are illuminated on Air- and Water-Cooled units, R1 is also energized on Remotes.) The Low Float Switch will go off as the water level rises.

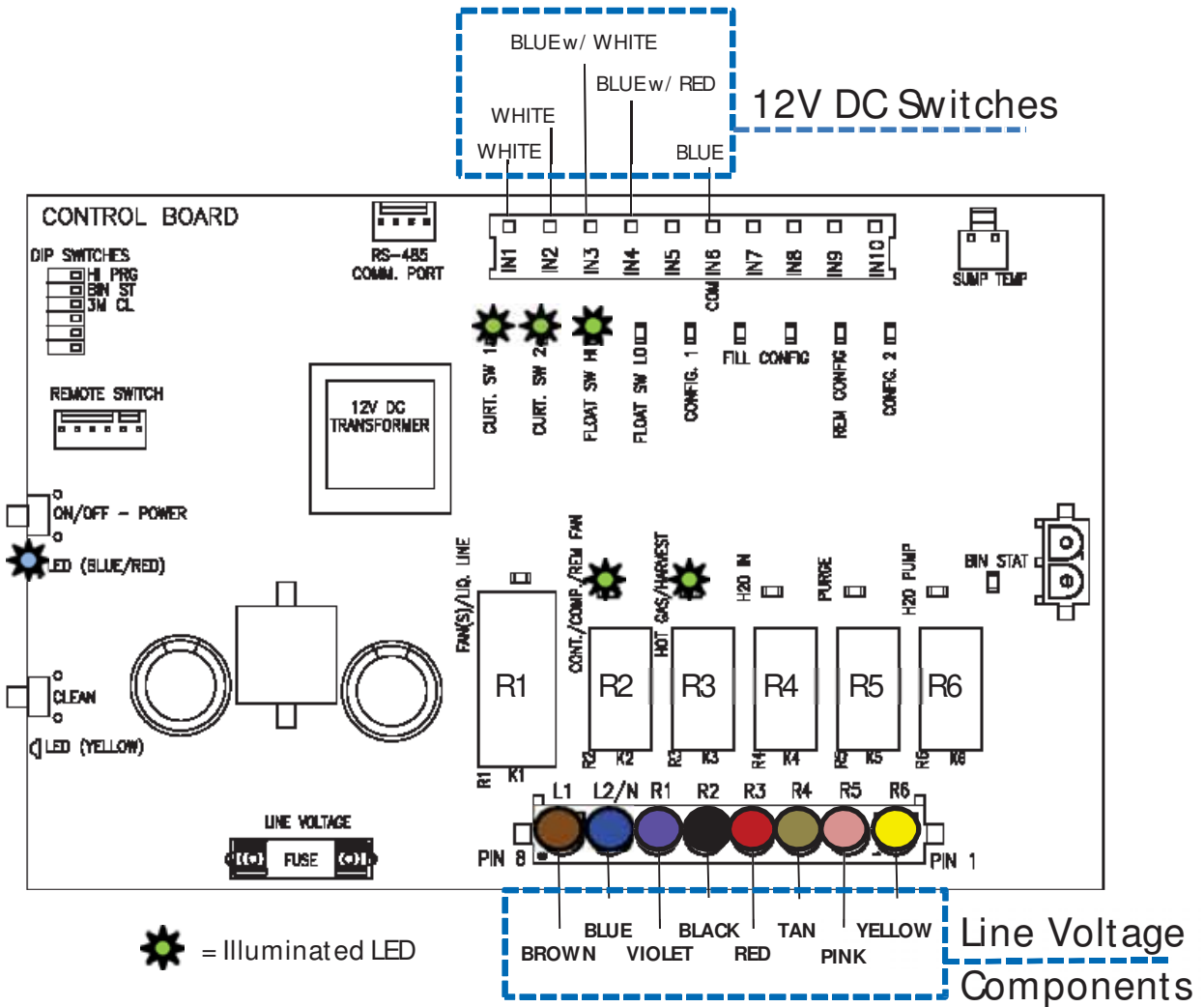

CONTROL BOARD - HARVEST

After the Water Inlet Valve closes following the 20 second time out, the Hot Gas Valve and Harvest Assist will remain energized until the ice slab is harvested from the Evaporator. At this point the unit is reading the Curtain Switch (s) and/or Bin Thermostat (if added).

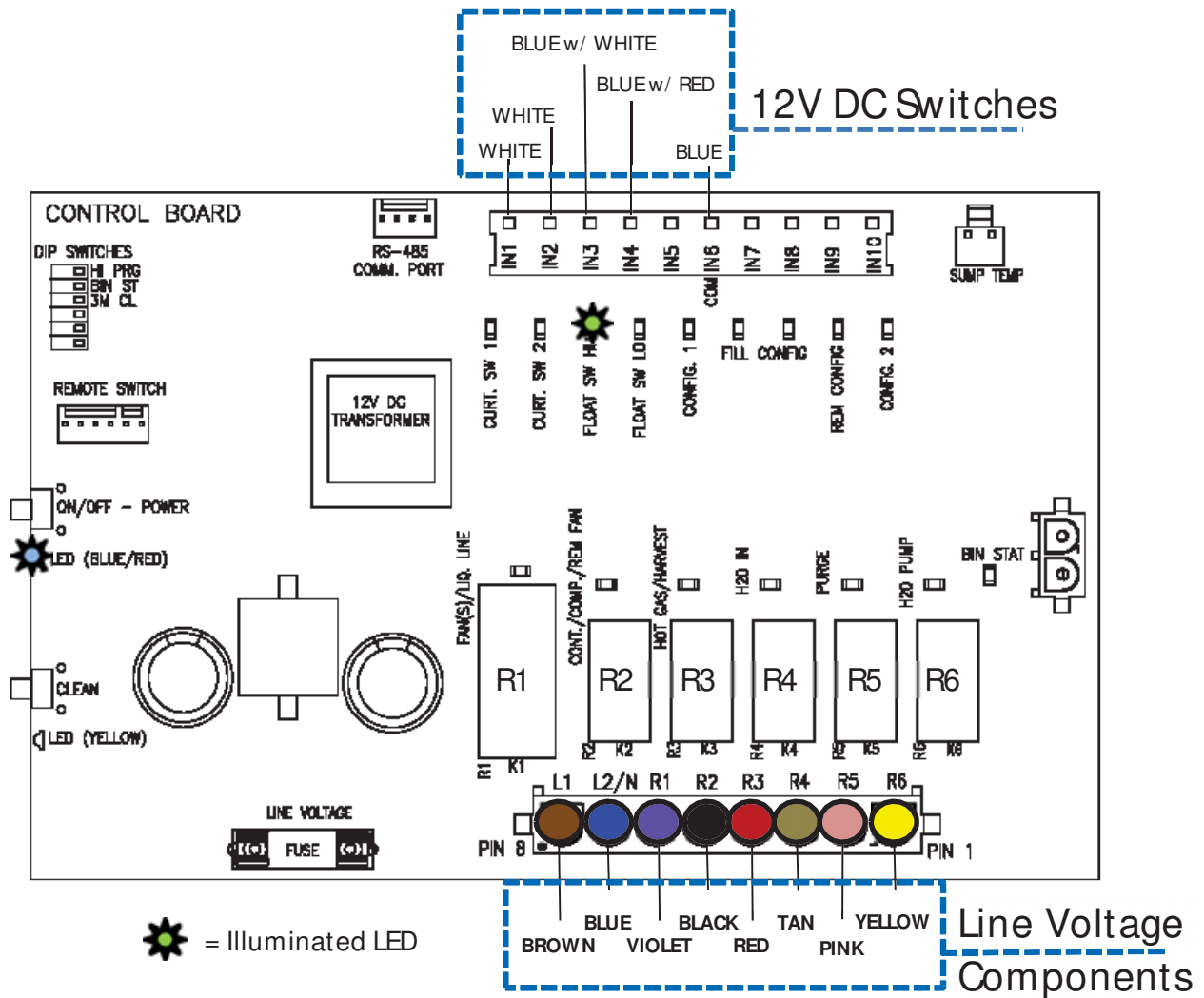

CONTROL BOARD - BIN FULL

When ice drops from the Evaporator, the Curtain switch opens. If it stays open for 30 seconds, the unit shuts down as the bin is full, turning off all RELAY LEDs (R1–R6). If the bin isn't full, the next cycle begins. Refer to page 28.

If the unit turns off due to a full bin or because the Bin Thermostat stays open for 90 seconds, it won't restart for 3 minutes to prevent compressor short cycling. Showing a slow Blue flashing light on the Display.

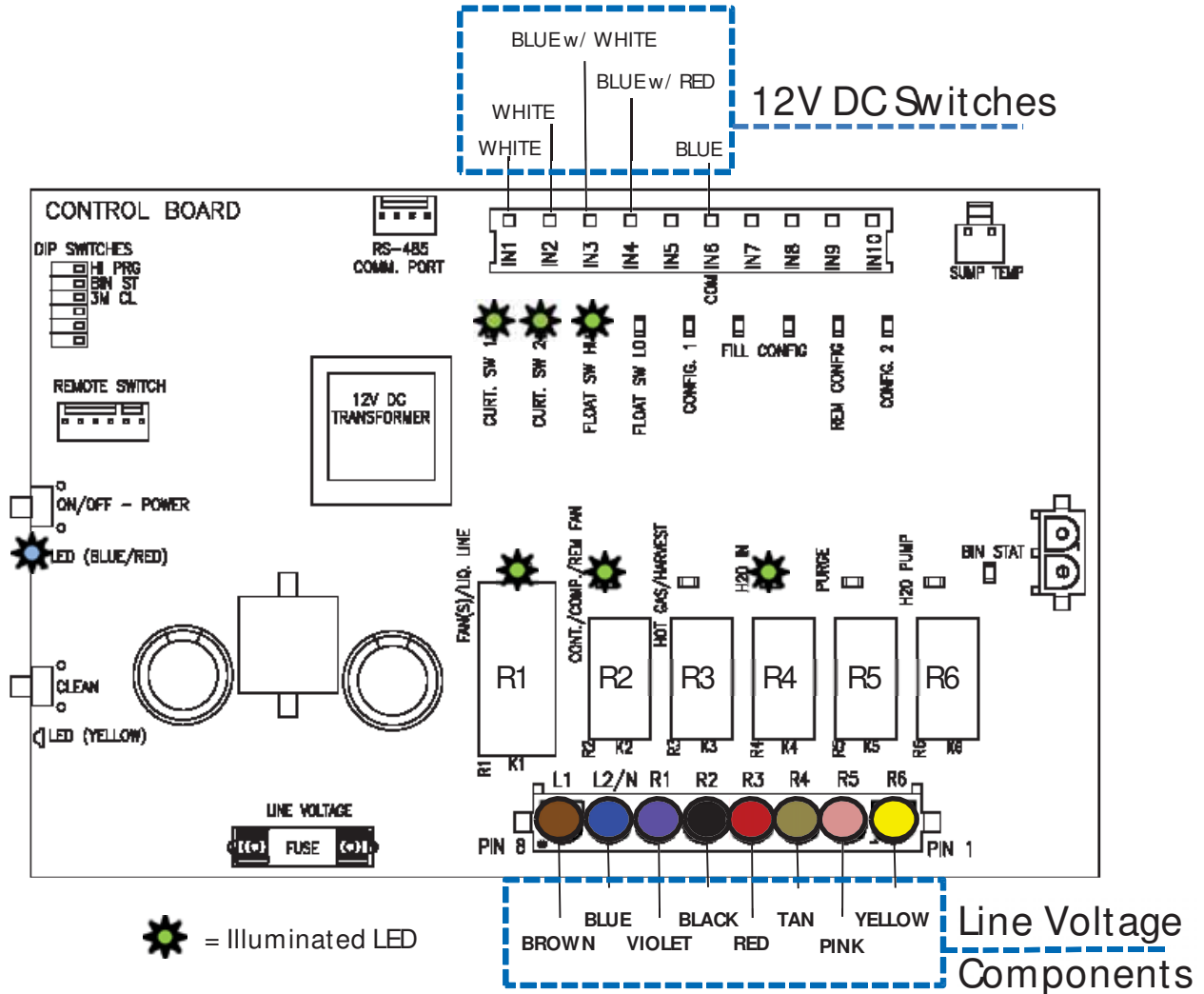

CONTROL BOARD - RETURN TO FREEZE

As the ice slab drops from the Evaporator, it moves the Curtain(s), which makes the Curtain Switch contacts open and close, ending the Harvest Cycle. If both the Curtain and the Bin Thermostat (if installed) are closed, the system starts the Freeze Cycle. During this phase, the Compressor (R2) and Fan(s) (R1) keep running, while the Water Inlet Valve (R4) turns on to fill the Sump until the High-Water Float opens de-energizing the water valve.

Control Board

Operation

The Board controls the operation of the unit. A series of LED lights show Switch positions and Component operation to assist the technician in understanding and troubleshooting issues that may arise. See Sequence of Operation pg. 9 for operational information.

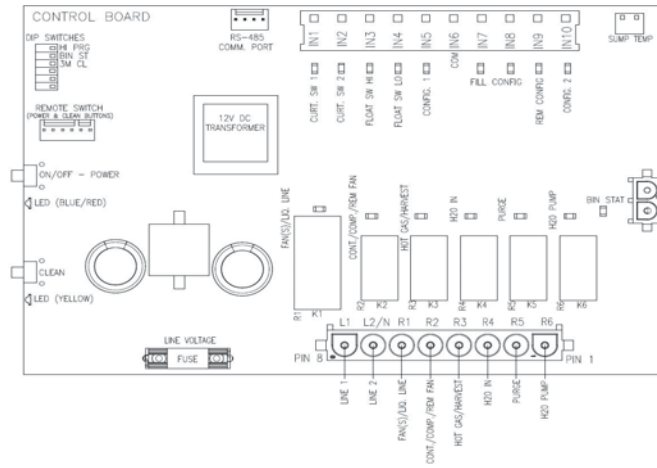

Control Board Features

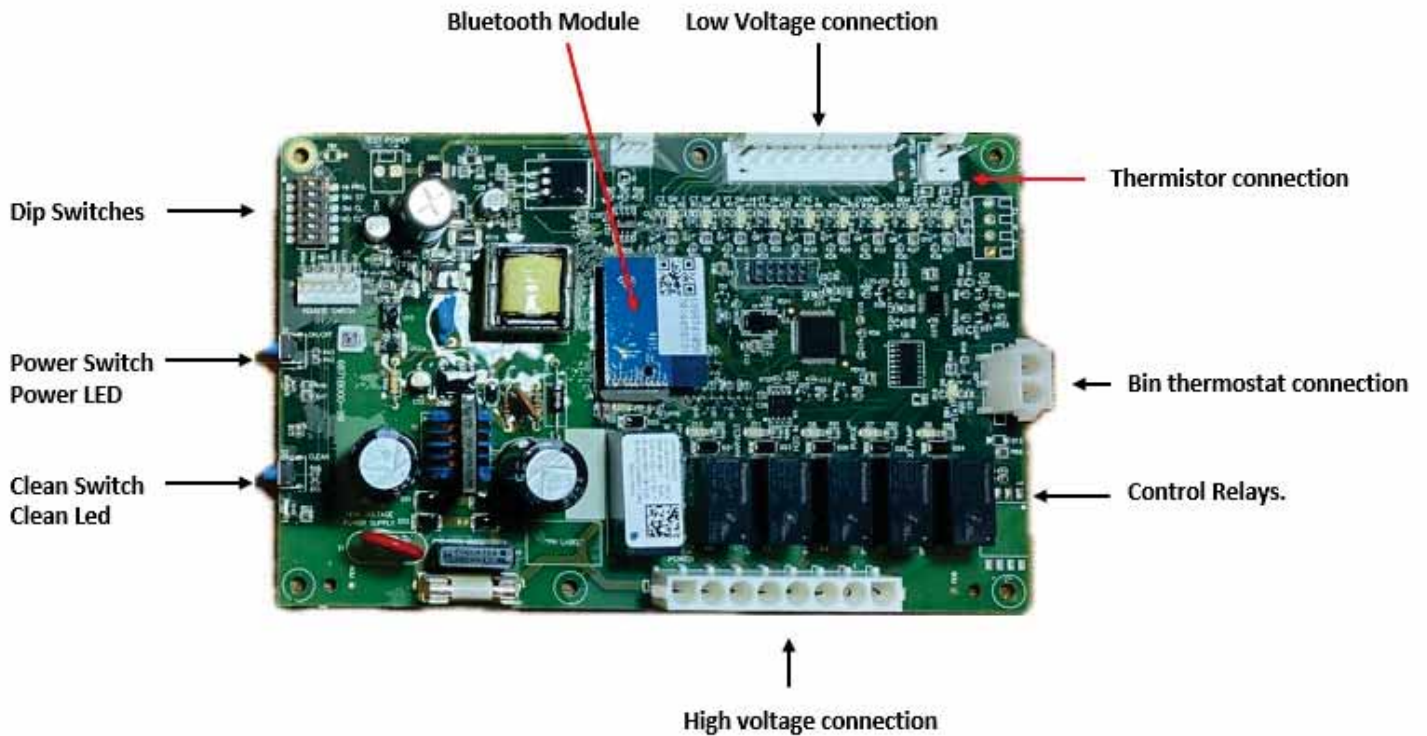

Adjustment Switch Block

Four adjustments can be made on the block. Extended Purge, Bin Thermostat Kit add-on and Cleaning Needed Reminder.

Standard Purge time during a Defrost Cycle is set at 7 seconds. To add an additional 40 seconds to the purge time, move Switch 1 to the right, to the ON position.

Should the unit be installed on top of a dispenser, a Bin Thermostat Kit is required. Following the instruction that comes with the kit, switch 2 needs to be moved to the ON position to tell the program to read the Bin Thermostat. The LED beside the Bin Stat Connection will then illuminate. Switch 3 on the block is for the Cleaning Needed Reminder. When in the OFF position, the default setting for the clean reminder is 6 months. When Switch 3 is moved to the ON position, the Reminder is set for every 3 months. This is recommended should the unit be installed in a hardwater location to help with production levels. Switch 4 turns off the clean reminder light. (not recommended).

Low Voltage connection (12VDC) for Control Switches

This Molex connects the Magnetic Curtain Switch(es), High Float Switch, Low Float Switch and Remote Configuration Switch to the Board. The LED's associated to each switch will illuminate when the contacts for each are closed. The Remote Configuration LED will be illuminated when the Smart Harness reads the unit has a Remote Condenser. The fill light indicates unit is over 800lbs and has to fill 2 times with water. Config1 (D2), (D16),and (D17) are not used.

Thermistor Connection

The Thermistor is used to gauge the water temperature in the Sump and is used to activate the Anti-Slush Cycle. When the water temperature reaches 36 degrees F during the first 3 cycles following a full bin situation, being restarted after a loss of power or turned off, the Water Pump will be turned off for 20 seconds to help prevent slushing of the water in the Sump. An Anti-Slush will also be performed any time the water temperature reaches 28 degrees F. Control Boards after ser. 2106 Shuts down the pump at 38° F for 20 seconds every cycle.

Control Relays

The six Control Relays send voltage out to the individual components during the operation of the unit. Relay 1 energizes the Fan(s) on self-contained air-cooled units or the Liquid Line Solenoid on Remotes. Relay 2 energizes the Compressor through the Contactor (and Fan Motor on Remotes). Relay 3 energizes the Hot Gas Valve and Harvest Assist Assembly during the Harvest Cycle. Relay 4 energizes Water Inlet Valve. Relay 5 energizes the Purge Valve. Relay 6 energizes the Water Pump.

Line Voltage Connection

The Line Voltage Molex connects each component to the Board. See the wiring diagram for each unit to see the wiring colors associated with each component.

Power and Clean Buttons

These buttons are functional duplicates of the buttons on the Push Pad mounted to the front frame of the unit. See also "Button Function" chart in this manual for operation.

Bluetooth Module

This allows a connection to the controller via **Ice-O-Matic's** Mobile app to help see the control board function. Downloadable on your Mobile app store.

Power and Clean LED Flash Description

SOLID - On Constantly

SLOW - Flashes once every second

QUICK - Flashes once every half second

DOUBLE - Flashes twice then 1 second delay

TRIPLE- Flashes Three times then 1second delay

DELAYED - flashes once every 3 seconds

Error Codes

Error 1 - POWER LED QUICK FLASH RED - Unit has experienced a MAX Freeze (1 hr.), on (Boards Pre 2106 ser. Only) MAX Harvest (5.5 minutes) or BOTH.

Error 2 - POWER LED SLOW FLASH IN OFF STATE ONLY - Thermistor Failure.

Error 3: POWER LED flashes red and CLEAN LED flashes yellow quickly. The unit experienced a MAX Fill (5 min) Current production. **Previously was Max Fill and/ or Max Purge Pre 2106 Serial**

Error 4 – DOUBLE RED AND DOUBLE YELLOW QUICK FLASH – Unit has experienced a MAX Purge (2 min.)

Error 5 – DOUBLE RED QUICK FLASH – Unit has Experienced a MAX Harvest (7.5 min)

Error 6 – TRIPLE RED QUICK FLASH – Unit has experienced MAX Freeze (1 hr.) and Max Harvest, (7.5 min)

Error 7 – TRIPLE RED AND TRIPLE YELLOW QUICK FLASH – Unit has experienced a Water Level Error (float did not close)

Minimum / Maximum Times

Freeze - 5 Minute Minimum / 1 Hour Maximum

Standard Harvest - 20 Second Minimum / 7.5 Minute Maximum
Current production. Previous was 5 minute Maximum boards prior to 2106

Water Fill - No Minimum / 5 Minute Maximum

Purge - 7 Second Minimum / 2 Minute Maximum

Board Led Sequence During Operation Test Control Boards to Serial 2106

INITIAL FREEZE CYCLE AT START-UP

<u>INITIAL FREEZE AT START-UP</u>		<u>OFF</u>	<u>FREEZE</u>						
			<u>POWER LED SOLID BLUE</u>						
<u>COMPONENTS</u>	<u>RELAY #</u>		<u>FILL VERIFICATION</u>	<u>PRESSURE EQUALIZE</u>	<u>PRESS. EQ. W/ COMPR.</u>	<u>PUMP DELAY</u>	<u>FREEZE</u>	<u>ANTI-SLUSH</u>	<u>FREEZE</u>
FAN(S) W/FAN CYCLE (A & W)	R1	-	-	-	ON	ON	ON	ON	ON
LIQ. LINE VALVE (REMOTE)	R1				ON	ON	ON	ON	ON
CONTACTOR/COMPRESSOR/REM. COND. FAN	R2	-	-	-	ON	ON	ON	ON	ON
WATER PUMP	R3	-	-	-	-	-	ON	-	ON
HOT GAS VALVE(S)	R4	-	-	ON	ON	-	-	-	-
HARVEST ASSIST(S)									
WATER INLET VALVE	R5	-	ON	-	-	-	-	-	-
PURGE VALVE	R6	-	-	-	-	-	-	-	-
NOTES:		VERIFY CONFIG 1 (PUMP DOWN FOR REM. ONLY)	HI FLOAT SW. OPEN	COMPRESSOR START UP - APPROX 5 SEC.	COMP. START UP - HGV CLOSURES AFTER APPROX 5 SEC.	PRE-CHILL THE EVAP PLATE - APPROX 30 SEC.	FREEZE	AT SIMPTEMP 36F. TURN OFF PUMP - APPROX 20 SEC.	CONTINUE FREEZE TO LOW FLOAT SW. CLOSE

INITIAL HARVEST CYCLE AT START-UP

INITIAL CYCLE AT START-UP (CONTINUED)		HARVEST					
		PURGE ON ENTERING HARVEST	TIMED FILL	WAIT FOR HARVEST	CURT. SW. OPENS		
COMPONENTS	RELAY #						
FAN(S) W/FAN CYCLE (A & W)	R1	-	-	-	-	-	-
LIQ. LINE VALVE (REMOTE)	R1	ON	ON	ON	ON	ON	ON
CONTACTOR/ COMPRESSOR/ REM. COND. FAN	R2	ON	ON	ON	ON	ON	ON
WATER PUMP	R3	ON	-	-	-	-	-
HOT GAS VALVE(S) HARVEST ASSIST(S)	R4	ON	ON	ON	ON	ON	ON
WATER INLET VALVE	R5	ON	ON	ON	ON	ON	ON
PURGE VALVE	R6	ON	-	-	-	-	-
NOTES:		TIMED SUMP FLUSH AND PURGE - APPROX 7 SEC.	INITIAL TIMED FILL 20 SECS. OR TO HIGH FLOAT SW. OPEN	WAITING FOR CURTAIN SW. OR BIN STAT	ICE RELEASED - HARVEST TERMINATED		

TRANSITION FROM HARVEST TO FREEZE

TRANSITION HARVEST -> FREEZE		CONTROLLER STATES							
		HARVEST				FREEZE			
		POWER LED SOLID BLUE							
COMPONENTS	RELAY #	HOT GAS-HAA/ PURGE/ WATER INLET	HOT GAS- HAA/TIMED FILL	HOT GAS/HAA	CURTAIN SW (1 & 2) OPEN	CURTAIN SW (1 & 2) CLOSE	PRE-CHILL AND FILL	FREEZE	
FAN(S) W/FAN CYCLE (A & W)	R1	-	-	-	-	-	ON	ON	
LIQ. LINE VALVE (REMOTE)	R1	ON	ON	ON	ON	ON	ON	ON	
CONTACTOR/ COMPRESSOR/ REM. COND. FAN	R2	ON	ON	ON	ON	ON	ON	ON	
WATER PUMP	R3	ON	-	-	-	-	-	ON	
HOT GAS VALVE(S) HARVEST ASSIST(S)	R4	ON	ON	ON	ON	ON	-	-	
WATER INLET VALVE	R5	ON	ON	-	-	-	ON	-	
PURGE VALVE	R6	ON	-	-	-	-	-	-	
NOTES:		TIMED SUMP FLUSH AND PURGE	INITIAL TIMED FILL 20 SECS. OR HIGH FLOAT SW OPENS	WAITING FOR CURTAIN SW.	CURT. SW. OPENS (MOMENT) ICE RELEASED	CURTAIN SW. CLOSES (MOMENT)	COOL THE EVAP PLATE AND FILL SUMP	5 MINUTE MIN. FREEZE TIME	

BIN FULL (CURTAIN OR STAT)

TRANSITION TO BIN FULL SHUTDOWN		HARVEST				BIN FULL	
		PURGE ON ENTERING HARVEST	TIMED FILL	WAIT FOR HARVEST	CURT SW/BIN STAT OPENS	BIN FULL / PUMP DOWN (REMOTES)	SYSTEM HOLD
COMPONENTS	RELAY #						
FAN(S)	R1	-	-	-	-	-	-
W/FAN CYCLE	(A/W)						
LIQ. LINE VALVE	R1 (REM)	ON	ON	ON	ON	-	-
CONTACTOR/COMPRESSOR/REM. COND. FAN	R2	ON	ON	ON	ON	ON (PUMP DOWN)	-
WATER PUMP	R3	ON	-	-	-	-	-
HOT GAS VALVE(S)	R4	ON	ON	ON	ON	-	-
HARVEST ASSIST(S)							
WATER INLET VALVE	R5	ON	ON	-	-	-	-
PURGE VALVE	R6	ON	-	-	-	-	-
NOTES:		TIMED SUMP FLUSH AND PURGE - APPROX 7 SEC.	INITIAL TIMED FILL 20 SECS. OR TO HIGH FLOAT SW. OPEN	WAITING FOR CURTAIN SW. OR TIME	ICE HARVESTED - CURT/BIN STAT REMAIN OPEN	CURT OR BIN STAT REMAIN OPEN - UNIT SHUT DOWN (REMOTES) PUMPDOWN APPROX 30 SEC)	BIN FULL WAIT FOR CURT/STAT TO CLOSE

DIAGNOSTICS IN FREEZE CYCLE

The Diagnostic sequence is started by pressing both the Power and Clean buttons for 6 seconds.

DIAGNOSTICS		CONTROLLER STATES							
		AT START-UP		FREEZE					
		FROM OFF STATE POWER LED RED SOLID	PURGE	FILL	PRES. EQUAL.	PRES. EQ. W/ COMPR.	FREEZE	ANTI-SLUSH	FREEZE
COMPONENTS	RELAY #								
FAN(S) W/FAN CYCLE	R1 (A/W)	-	-	-	-	ON	ON	ON	ON
LIQ. LINE VALVE	R1 (REM)	-	-	-	-	ON	ON	ON	ON
CONTACTOR/ COMPRESSOR/ REM. COND. FAN	R2	-	-	-	-	ON	ON	ON	ON
WATER PUMP	R3	-	ON	-	-	-	ON	-	ON
HOT GAS VALVE(S) HARVEST ASSIST(S)	R4	-	-	-	ON	ON	-	-	-
WATER INLET VALVE	R5	-	-	ON	-	-	-	-	-
PURGE VALVE	R6	-	ON	-	-	-	-	-	-
NOTES:		VERIFY CONFIG 1 (PUMP DOWN FOR REM ONLY)	VERIFY EMPTY SUMP; LOW FLOAT SW. CLOSED	HI FLOAT SW. SATISFIED	HOT GAS OPEN APPROX 5 SEC	CONTACTOR/ COMPRESSOR STARTUP - HOT GAS CLOSES AFTER 5 SEC	5 MINUTE MIN. FREEZE TIME	AT SUMP TEMP 3AF. TURN OFF WATER PUMP FOR 30 SEC	LOW FLOAT SW. CLOSE TO INITIATE HARVEST
		QUICK PRESS POWER AND CLEAN BUTTON ADVANCES TO NEXT STATE		QUICK PRESS POWER AND CLEAN BUTTON ADVANCES TO NEXT STATE					

Board Led Sequence During Operation Test Control Boards from 2106 REV C1

INITIAL START-UP THROUGH FREEZE CYCLE

CONTROLLER STATE										
FREEZE BLUE LED (SOLID)										
COMPONENTS	RELAY #	FILL VERIFICATION	PRESSURE EQUALIZE	PRESS. EQ. W/ COMPR.	PUMP DELAY	FREEZE	ANTI-SLUSH	2nd FILL (units over 800lbs)	TIMED FREEZE	
FAN(S) W/FAN CYCLE	K1 (A/W)	-	-	ON	ON	ON	ON	ON	-	
CONT/COMP/ REM. COND. FAN	K2	-	-	ON	ON	ON	ON	ON	ON	
WATER PUMP	K3	-	-	-	-	ON	-	ON	ON	
HOT GAS VALVE(S)	K4	-	ON	ON	-	-	-	-	-	
HARVEST ASSIST(S)										
WATER INLET VALVE	K5	ON	-	-	-	-	-	ON	-	
PURGE VALVE	K6	-	-	-	-	-	-	-	-	
NOTES:		Will Purge sump if Hi float switch is open to ensure correct amount of water in trough.	IMPROVE COMPRESSOR START UP	IMPROVE COMPR. START UP	PRE-CHILL PLATE	MIN. FREEZE TIME (SP18)	AT SUMP TEMP 38°F, TURN OFF PUMP	LOW FLOAT SW. WITH DEBOUNCE	ABILITY TO TURN OFF FANS IF NEEDED	
TIME:		0 SECS TO MAX. FILL TIME	5 SECS	5 SECS	30 SECS (5 MIN OR MAX FREEZE	20 SECS	APPROX. 5 MIN INTO CYCLE	0 SECS	

TRANSITION FROM FREEZE INTO HARVEST

NOTE: Orange shaded area is for extended harvest on new control

CONTROLLER STATE										
HARVEST BLUE LED (SOLID)										
COMPONENTS	RELAY #	HOT GAS/ PURGE/RINSE	PURGE	TIMED FILL	HARVEST	EXTENDED HARVEST	EXTENDED HARVEST	EXTENDED HARVEST	EXTENDED HARVEST PURGE	HARVEST COMPLETE/ START FRZ
FAN(S) W/FAN CYCLE AIR/WATER	K1 (A/W)	-	-	-	-	-	-	-	-	ON
LIQ. LINE VALVE REMOTE ONLY	K1 (REM)	ON	ON	ON	ON	ON	ON	ON	ON	ON
CONT/COMP/ REM. COND. FAN	K2	ON	ON	ON	ON	ON	ON	ON	ON	ON
WATER PUMP	K3	ON	ON	-	-	-	ON	ON	ON	ON
HOT GAS VALVE(S) HARVEST ASSIST(S)	K4	ON	ON	ON	ON	ON	ON	ON	-	-
WATER INLET VALVE	K5	ON	ON	ON	-	ON	-	-	-	ON
PURGE VALVE	K6	ON	ON	-	-	-	-	-	ON	-
NOTES:		TIMED RINSE AND PURGE	PURGE	INITIAL TIMED FILL 20 SECS.	WAITING FOR CURTAIN SW.	WAITING FOR CURTAIN SW. OR TIME (PRIORITY) ADD: HI FLOAT SW. SATISFIED	WAITING FOR CURTAIN SW. OR TIME			
TIME:		5 SECS	10 SECS	20 SECS TO MAX. FILL TIME	30 SEC TO MAX HARVEST 5 MIN	ONLY IF LONGER THAN 5 MIN HARVEST 30 SEC TO MAX FILL	ONLY IF LONGER THAN 5 MIN 2.5 MIN TO HARVEST			

Button Functions

BUTTON FUNCTIONS			
	BUTTON PRESS		
	POWER	CLEAN	
OFF RED SOLID	QUICK	-	FREEZE
	3 SEC	-	INDICATE CODE REVISION
	-	QUICK	CLEAN CYCLE
	3 SEC	3 SEC	CLEAR ERROR CODES AND RESET COUNTERS (SINGLE BLUE/ YELLOW LIGHT FLASH WHEN RESET)
	6 SEC	6 SEC	RUN DIAGNOSTICS PROGRAM
BIN FULL ON CURTAIN/ BIN STAT BLUE SOLID	6 SEC	-	MACHINE OFF
NORMAL OPERATION FREEZE/ HARVEST BLUE SOLID	QUICK	-	MANUAL HARVEST 1 - FINISHES THEN SHUTS OFF
	3 SEC	-	MANUAL HARVEST 2 - IMMEDIATE Harvest and shuts off
	6 SEC	-	MACHINE OFF
CLEAN IN PROCESS RED SOLID/ YELLOW SLOW	-	QUICK	ADVANCE TO PURGE AFTER MIN. OF 5 MIN OF
	6 SEC		CLEAN IN PROCESS
OFF - CLEAN IN PROCESS RED SOLID/ YELLOW SLOW	-	QUICK	RETURN TO CLEAN IN PROCESS - PURGE/ RINSE
CLEAN COMPLETE RED SOLID/ YELLOW SOLID	-	QUICK	Exit Clean complete MACHINE OFF
	QUICK	-	Exit Clean complete MACHINE OFF
ANY STATE	6 SEC	-	MACHINE OFF
DIAGNOSTICS RED DOUBLE SLOW	QUICK	QUICK	ADVANCE TO NEXT STATE
	6 SEC	-	MACHINE OFF
ERROR 1 RED QUICK ERROR 3 RED & YELLOW QUICK ERROR 4 DOUBLE RED & YELLOW QUICK ERROR 5 DOUBLE RED QUICK ERROR 6 TRIPLE RED QUICK ERROR 7 TRIPLE RED & YELLOW			3 SEC Same as Below
	3 SEC	3 SEC	CLEAR ERROR CODES AND RESET COUNTERS (SINGLE BLUE /YELLOW LIGHT FLASH WHEN RESET)
			3 SEC
RINSE BLUE SLOW	QUICK	-	ADVANCE TO FREEZE
HARVEST VERIFICATION BLUE SLOW	QUICK	-	NO ACTION (CURTAIN SWITCH OPEN/ CLOSE TO ADVANCE)
DEFAULT HARVEST BLUE SLOW	QUICK	-	NO ACTION (CURTAIN SWITCH OPEN/ CLOSE TO ADVANCE)
MANUAL HARVEST 1 DURING FREEZE OR HARV. BLUE QUICK	QUICK	-	RETURN TO NORMAL OPERATION BLUE SOLID
MANUAL HARVEST 2 DURING HARVEST BLUE QUICK	QUICK	-	RETURN TO NORMAL OPERATION BLUE SOLID

Sump

The Sump holds the potable water for the Freeze Cycle. It is located under the Evaporator and accessible from the front of the unit. The Sump must be removed to access the Water Pump and the Float Switch Housing.



22" and 30" Units Sump Removal

First remove the Splash Curtain and Splash Guard.



Disconnect Water Pump Tube as shown above and tuck backside of tube into the Sump.

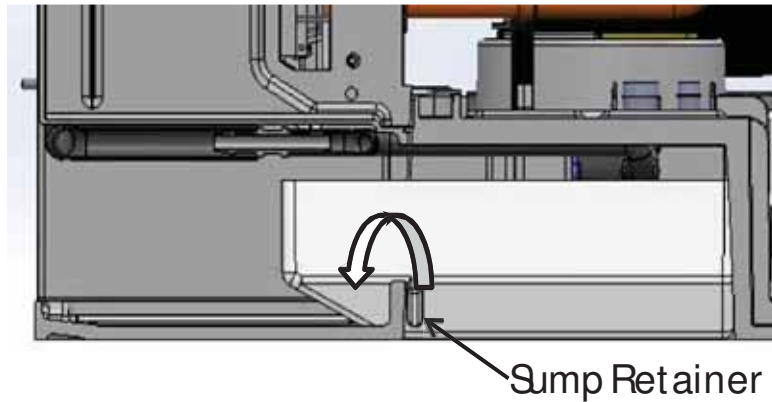

Lift the front of Sump and pull forward to clear the Sump Retainers from the frame.

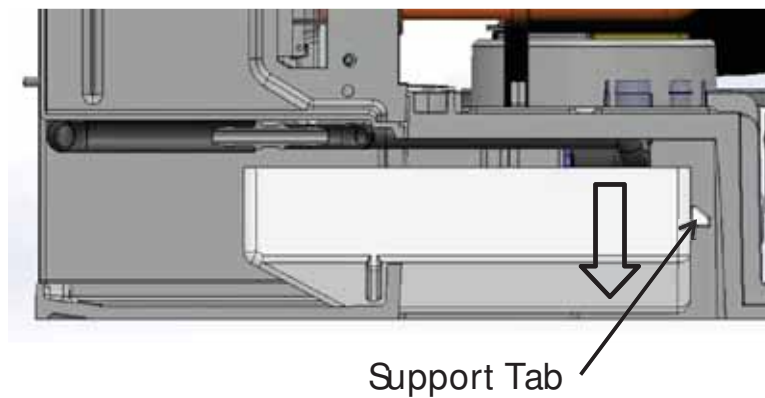

With the Support Tabs now clear of the frame, allow the back of the Sump to fall clear of the frame.

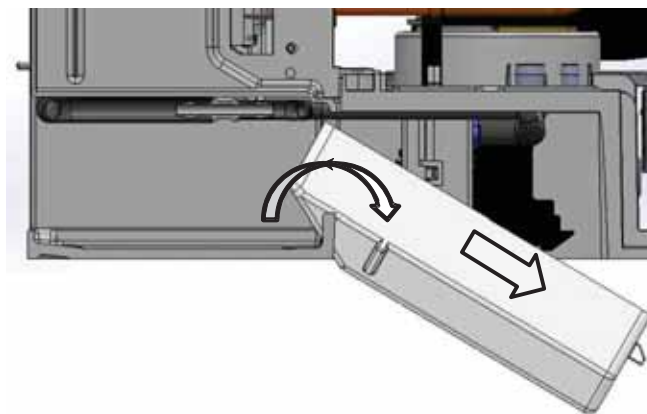

Again, lift the front of the Sump and push towards the back and down until Sump is clear of the frame. Turn the Sump sideways and remove through the ice drop zone.

To reinstall, reverse process making sure to tuck Water Pump Tube into Sump as lift Sump into place.

48" Unit Sump Removal

Removal of the splash curtain and splash guard is the same as the 22" and 30" units. You will do this twice as there are two of each for the 48" units. The Water Pump Tube will need to be disconnected also and this is the same process as in the 22" and 30" units as well. Tuck the backside of the tube into the sump to keep it out of the way during sump removal.

Starting on the right side, lift up and pull forward to move the sump over the right-side retention feature.



Next, lower the right side of the sump into the bin and release the left side of the sump.

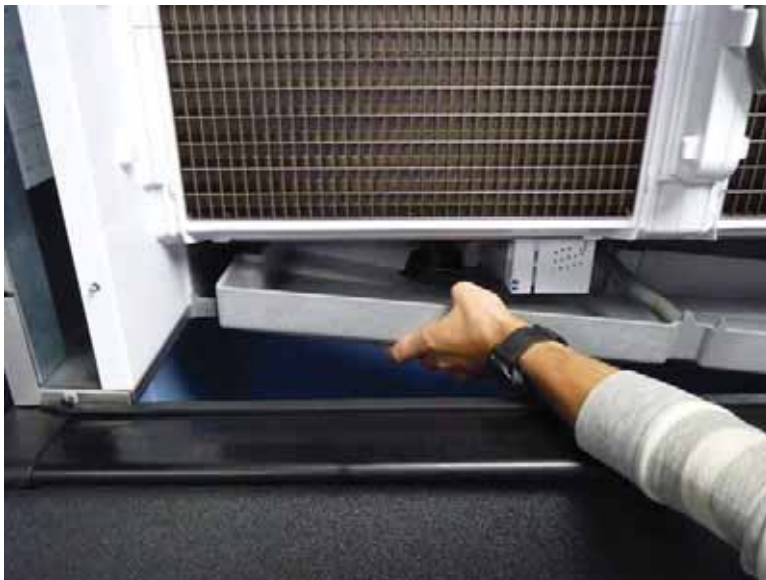

After the sump is released from the retention features, lower the entire sump into the bin and rotate it so it will come out the front of the unit.



Slowly remove the sump from the bin so as to not hit and damage other components.



Installation of the sump is the reverse of removal. To ease the installation using one hand under the sump pan to lift on the back will help with the install. Ensure the left side is seated properly, before attempting to press the right side into place. ***Improper placement of the left side can lead to damage of the retention features during installation.***

High and Low Float Switches and Housing

Float Housing Assembly

The Float Switch Housing Assembly contains the High and Low Float Switches along with the Sump Thermistor. See below for the function of each. See also Sequence of Operation pg. 15.

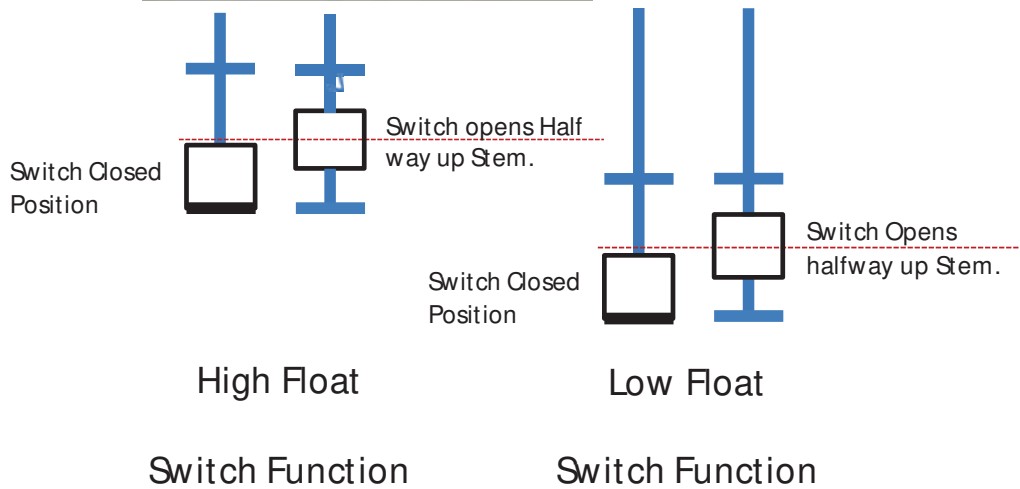
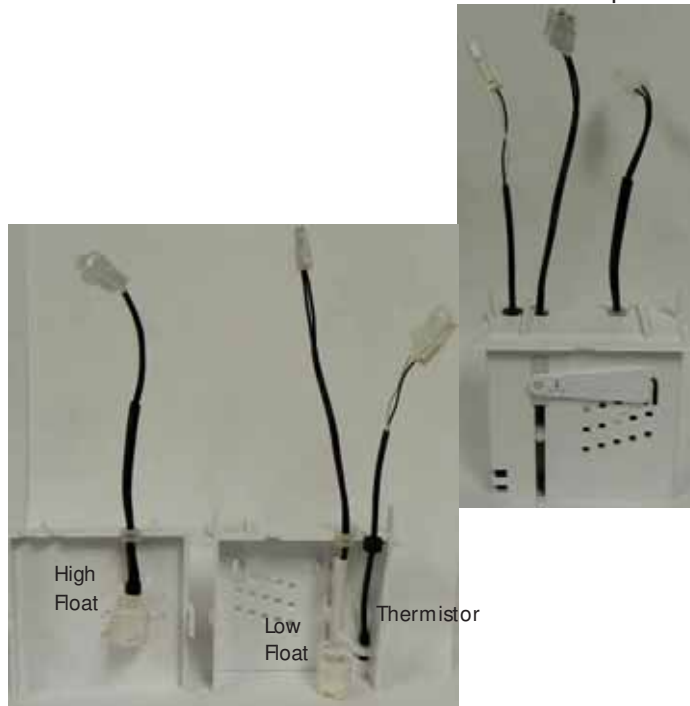

The High Float Switch is used to control the water level for ice making, cleaning and sanitizing. The Float will rise with the water level, opening the contact of the switch and signal the Board to close the Water Inlet Valve. The LED associated with the High Float switch will be ON when the contacts of the switch are closed and will turn OFF when the contacts open. The Low Float Switch is used to determine when the unit is ready to go into the Harvest Cycle during ice production and when the Sump has been emptied of cleaner or sanitizer during the Cleaning Cycle.

High and Low Float Switch Operation

The High Float Switch is used to control the water level for ice making, cleaning and sanitizing. The Float will rise with the water level, opening the contact of the switch and signal the Board to close the Water Inlet Valve. The LED associated with the High Float switch will be ON when the contacts of the switch are closed and will turn OFF when the contacts open. The Low Float Switch is used to determine when the unit is ready to go into the Harvest Cycle during ice production and when the Sump has been emptied of cleaner or sanitizer during the Cleaning Cycle

The LED associated with the Low Float Switch operates the same as the LED for the High Float Switch. The LED will ILLUMINATE when the contact of the float is closed and will turn OFF when the contacts are open. The Thermistor monitors the water temperature in the Sump during the Freeze Cycle. At 38°F the system initiates an “Anti-slush” shutdown of the Water Pump for 20 seconds when the water temperature reaches 38°F to decrease the risk of slushing in the Sump. Additionally, the system will perform an anti-slush shutdown of the Water Pump whenever the water temperature reaches 28°F.

Troubleshooting

When the High and Low Floats are in the down position, the contacts for the switches are closed and the LEDs on the Board should be illuminated.



Low Float Switch LED
High Float Switch LED

As the water level rises, the floats rise with it and the contacts of the switches will open and the LEDs on the Board will go OFF. This can be verified by removing the Sump and checking first the LEDs on the Board. Without the presence of water, both floats should be in the down position and the LEDs on the Board should be illuminated. If one or both LEDs are OFF, disconnect the Float Switches at the connectors along with the Thermistor and remove the Float Housing by gently pulling down on it from the ice drop zone.

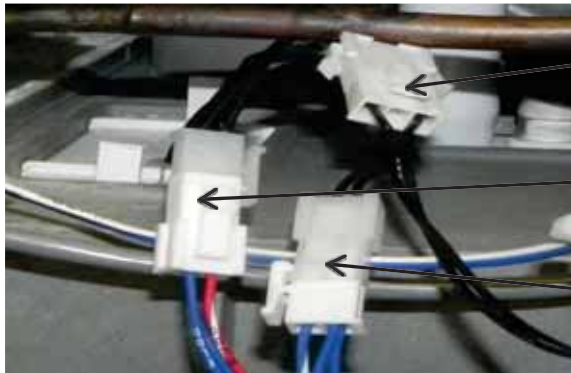

Thermistor Connector

High Float Switch Connector

Low Float Switch Connector

Open the housing and examine each float for movement of the float and cleanliness. With a meter set on continuity, verify the contacts on the float open and close with movement of the float. If float is clean and contacts do not change with float movement, replace Float Switch Housing Assembly. If one or both of the LEDs remain OFF with Float Switches that are known to be good, the Board or Wiring Harness may be the issue. Keep in mind: sometimes the LEDs will be on even if the unit isn't working. If there's resistance in the switch, a small amount of voltage might pass through—just not enough for the control to operate.

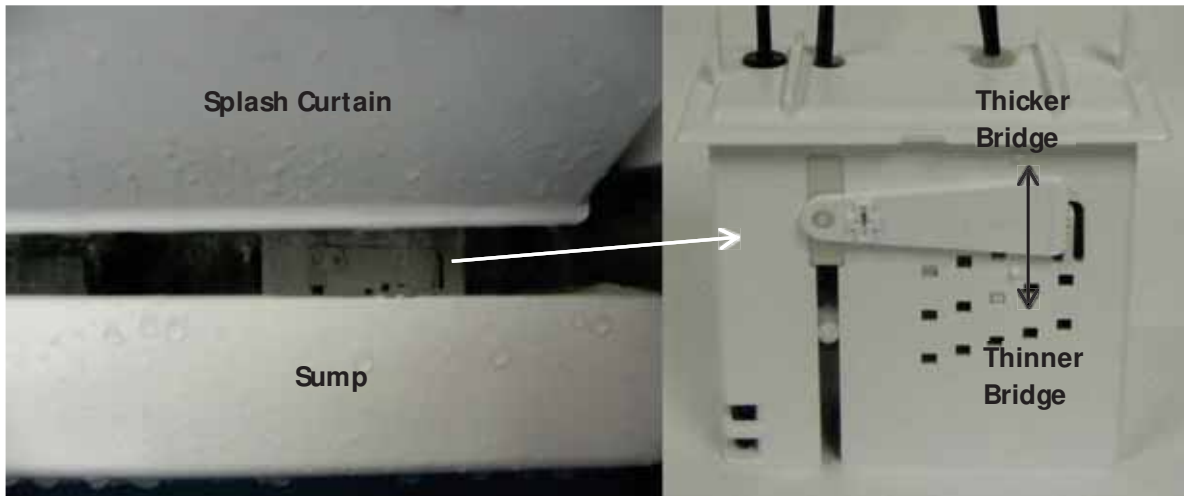

The Bridge Thickness on units under 400# production should be 3/16" while units over 400# production should be 1/8" thick when measured across the middle of the plate. Minor Adjustments can be made to the bridge thickness by moving the Water Level Adjustment Arm of the Float Housing up for a thicker bridge or down for a thinner bridge. This adjustment can be made at any time during the freeze or defrost cycle and the results verified on the following cycle.

Model	Half Cube	Full Cube	Grande Cube
CIM03**	#2	#3	-
CIM04**	#8	#9	-
CIM05**	#8	#9	-
CIM06**	#8	#9	-
CIM08**	#3	#4	#5
CIM11**	#3	#4	-
CIM14**	#4	#5	-
CIM18**	#4	#5	-
CIM20**	#4	#5	-

Recommended Float Setting Chart.

To make this adjustment the water trough, Splash guard, and lower water curtain will need to be removed. Pull gently down on the float, the float will come out through the bottom of the machine and this setting can then be made.

Water Pump

Operation

Relay 6 (LED ON) powers the Water Pump after a 30-second evaporator pre-chill during the Freeze Cycle. At the start of the Freeze Cycle following shutdown (OFF or Bin Full), the Water Pump pauses for 20 seconds to prevent sump slushing before running normally. The pump operates continuously during the Cleaning Cycle once the Sump is filled.

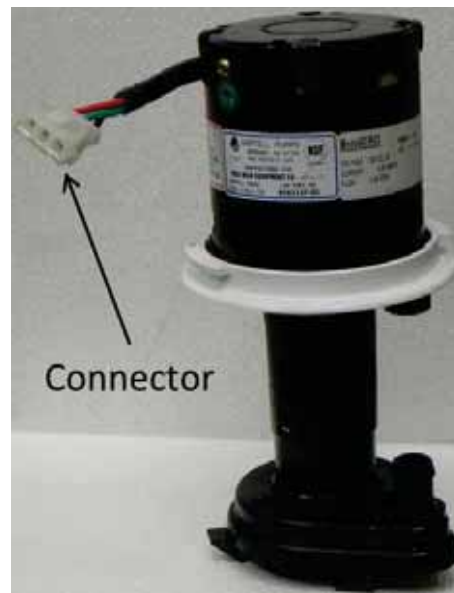

Troubleshooting

If Relay 6 LED is ON but the Water Pump does not run, verify line voltage between the Yellow and Blue wires on the Molex. If line voltage isn't found, verify connection of Molex to Board and reverify. If no voltage is found, the issue is the Board. If line voltage is found, verify line voltage at Water Pump connector. If no voltage is found, the issue is the wiring or connectors. If line Voltage is found, but the Water Pump won't spin, the issue is the Water Pump. Clean or replace as required.

When verifying voltage out of Board, check at the Blue and Yellow wires.



Voltage can also be checked at the connector at the Water Pump.

Water Pump Removal



The “foot” of the Water Pump points towards the right front corner of the unit. Grasp the foot and turn counterclockwise. When the foot points towards the right rear corner, you will feel the weight of the pump as the collar clears the base connections. Lower the Water Pump and disconnect. Reinstall the Water Pump by first making the electrical connection, the push Pump up pointing the Foot at the right rear corner and turn clockwise to secure.

Water Distribution Tube

The Water Distribution Tube has an inner tube and an outer tube. The water enters through the inner tube and sprays the water up into the outer tube relieving the pressure on the water. Gravity takes over and the water runs out the outer tube holes pointed down. The water runs smoothly and evenly over the Evaporator.



Removal and Disassembly

Disconnect Water Pump Tube from Water Distribution Tube.



Gently squeeze the tabs inward on the Water Distribution Tube and forward towards the front of the unit.

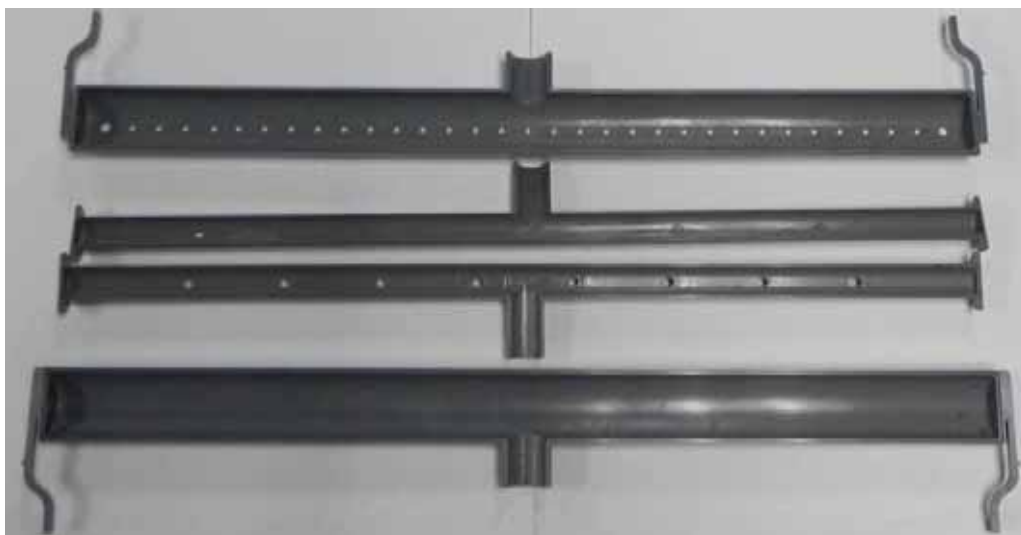

The Water Distribution Tube comes apart easily. It should be taken apart and cleaned regularly along with the rest of the unit. The pieces are Poka-yoke, meaning it only goes back together one way.

Water Inlet Valve

Operation

Relay 4 on the Board (LED ON) energizes the Valve first on initial startup to fill the Sump until the contacts of the High Float Switch open, indicating a proper amount of water for ice making. The purpose is to verify water supply before starting the unit. After the initial cycle is complete, the Valve will be energized during the Harvest Cycle and if needed, energized during the Pre-Chill to complete filling the Sump (See Sequence of Operation pg. 9). In either case, Relay 4 will be illuminated when the Water Inlet Valve is energized. During the Cleaning and Sanitizing Cycle the Water Inlet Valve will be energized several times during the rinse and purge portion of the cycle (see Cleaning Instructions pg. 56).



Troubleshooting

The High Float Switch contacts must open within 5 minutes. If Relay 4 is on but the Water Inlet Valve doesn't open, first check the water supply. Then check for line voltage between the (tan and blue) Molex wires. If absent, the Board is faulty; if present, check voltage at the Water Inlet Valve coil. No voltage means faulty wiring or connectors. If voltage is present, test coil resistance—no resistance indicates an open coil, so replace the valve. If the coil is fine, inspect and clean or replace the Water Inlet Valve as needed, and check incoming water supply and filters for blockages.



Voltage can also be verified at the connector at the coil of the Water Inlet Valve.

Purge Valve

Operation

The Purge Valve is located on the back of the Evaporator. The Valve should open when energized by Relay 5 on the Board (LED ON) during the Harvest Cycle to help empty the mineral laden water (see Sequence of Operation pg. 9) and during the Cleaning/ Sanitizing Cycle (see Cleaning Instructions pg. 56).



Troubleshooting

The Purge Valve, located behind the Evaporator, opens when Relay 5 (LED ON) is energized during the Harvest and Cleaning/ Sanitizing Cycles to remove mineral-rich water. If the valve does not open when Relay 5's LED is lit, unplug the coil connector and check for line voltage. If there is none, check the output at the board's Molex (pink and blue wires). No voltage means the board is faulty; if voltage is present, the issue is with the wiring between the Molex and the valve connector.

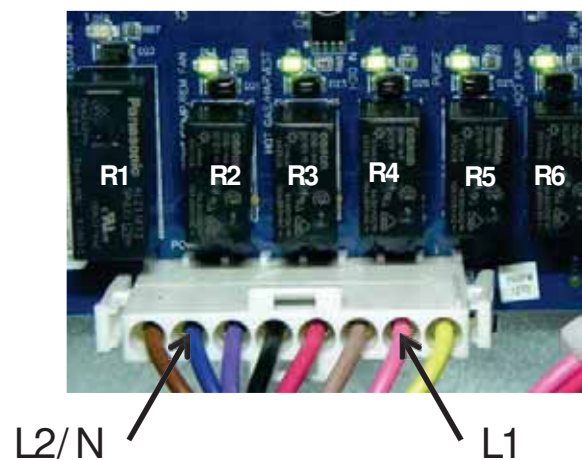

Voltage can also be verified at the connector at the coil on the Purge Valve.

Harvest Assist Assembly/Hot Gas Valve

Operation

The Harvest Assist Assembly is mounted to the back of the Evaporator Assembly. It is energized by Relay 3 along with the Hot Gas Valve. As the unit enters the Harvest Cycle, Relay 3 will illuminate indicating voltage is being sent to the Harvest Assist Assembly and the probe will be pushed forward to meet the ice slab. As the Evaporator warms, the Probe on the Harvest Assist will move forward to help release the ice from the plate. As the ice slab falls it will open the Magnetic Curtain Switch contacts. Relay 3 will then be de-energized, and the Harvest Assist will automatically return to the starting position.



Troubleshooting

The Harvest Assist Assembly is powered by the Hot Gas Valve via Relay 3 during Defrost. To test, enter Diagnostics by holding Power and Wash for 6 seconds, then quickly press both Power and Clean to start Harvest (R2-R6 LEDs should light up). Ensure Relay 3's LED is on and check voltage between Blue and Red at Molex. No voltage suggests a problem with the Board or Molex. If voltage is present, check at the Harvest Assist connector. If voltage exists but the probe doesn't advance, the Harvest Assist is faulty.

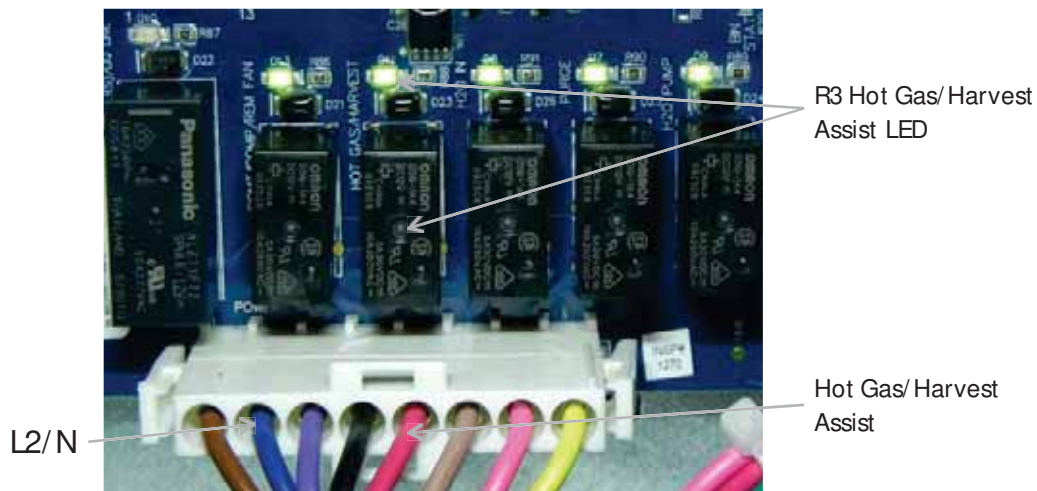

Magnetic Curtain Switch

The Magnetic Curtain Switch is a proximity switch that closes the contacts when the Splash Curtain closes. LEDs on the Board indicate a closed switch when illuminated.

Note: In 48” units there is a curtain magnet and proximity switch for both plates, on the left and right sides of the unit.



Troubleshooting

Should the LEDs on the Board be off when the Splash Curtain is closed, first verify the magnet is in place on the Splash Curtain and the Wiring Harness is properly connected at the Switch and at the Board. If all is verified, use a different magnet against the switch. If it still will not close, replace the Magnetic Curtain Switch. *Keep in mind: sometimes the LEDs will be on even if the unit isn't working. if there's resistance in the switch, a small amount of voltage might pass through—just not enough for the control to operate.*

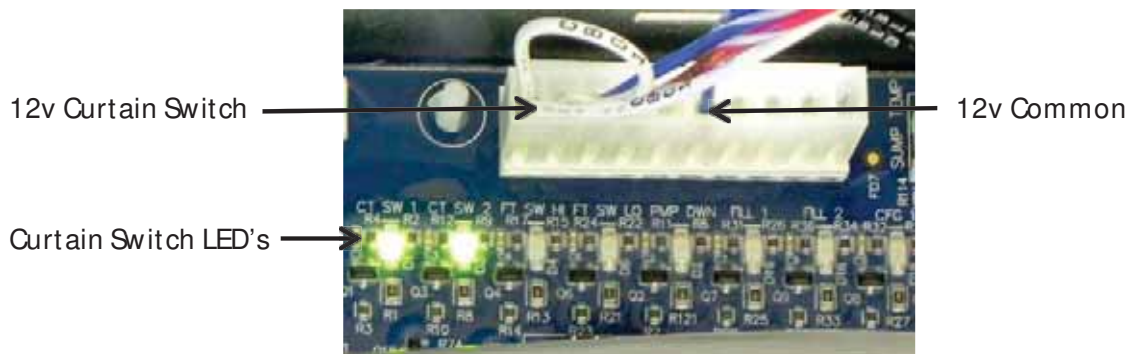

High Pressure Cut-out and Fan Cycle Switch

High Pressure Cut-out (left)

The High-Pressure Cut-out is set to open at 450 psig (r-404, and R-449a models), 350 on r-290 models and de-energizes the Contactor as a safety on the unit.

Fan Cycle Control (right)

The Fan Cycle Control helps maintain head pressure in cooler ambient temps. The control closes at 250 psig, energizing the Fan Motor and opens at 190 psig. The fan control is not needed in normal operating conditions and should only be placed in circuit if the temps drop below 60° F (15.5°C)



Troubleshooting

High Pressure Cut-out

The High-Pressure Cut-out opens at 450 psig to de-energize the Contactor and shutdown the Compressor. The control recloses at 350 psig. Should the control open during the Freeze Cycle, the unit may go into Error 1 state, indicating the Freeze Cycle has run for more than 1 hour. To quickly check the unit operating pressure, run a Diagnostic Cycle with stub gauges on the unit. A dirty or blocked Condenser, failed Fan Cycle Control, failed Fan Motor, high side restriction or refrigerant over charge can be the cause. **Note R-290 Models will have a 350psi open and a 250 psi close.**

Fan Cycling Control

The Fan Cycle Control is designed to close at 250 psig and open at 190 psig, helping regulate head pressure when conditions are cool. If the control activates at pressures outside this range, it should be replaced. R-290 units do not include a fan cycle control. **NOTE: R-290 units will not have a fan cycling control.**

Fan Motor

Operation

The Fan Motor (Self-Contained Air-Cooled Units) is Mounted to the Fan Shroud covering the Condenser at the rear of the unit. It is energized by Relay 1 and controlled by the Fan Cycling Switch. The Switch should close at 250 psi of head pressure and power the Motor. The Fan Cycle Switch (if *equipped*) should open at 190 psi of head pressure, and the Fan Motor will de-energize.



Troubleshooting

When the Fan Motor is inoperable or cycling outside of the operational parameters, first verify the LED for Relay 1 is illuminated, indicating the Board is calling for the Fan Motor to run. If the unit is in the Freeze Cycle and the LED is not illuminated, the issue may be the board. If it is illuminated, check voltage between the Violet and Blue with a meter. Line voltage should be shown. If inappropriate voltage is shown, verify the Molex connection at the Board and correct if loose. If there is still no voltage out, replace the Board. If voltage is verified, check contacts of Fan Cycle Switch for voltage then check contacts which should be closed at pressures above 250 psi. If open in these conditions, jump control. If Fan Motor comes on, issue is Fan Cycling Control. If the Motor does not come on, check the connection at Motor. If verified, the issue is the Fan Motor.

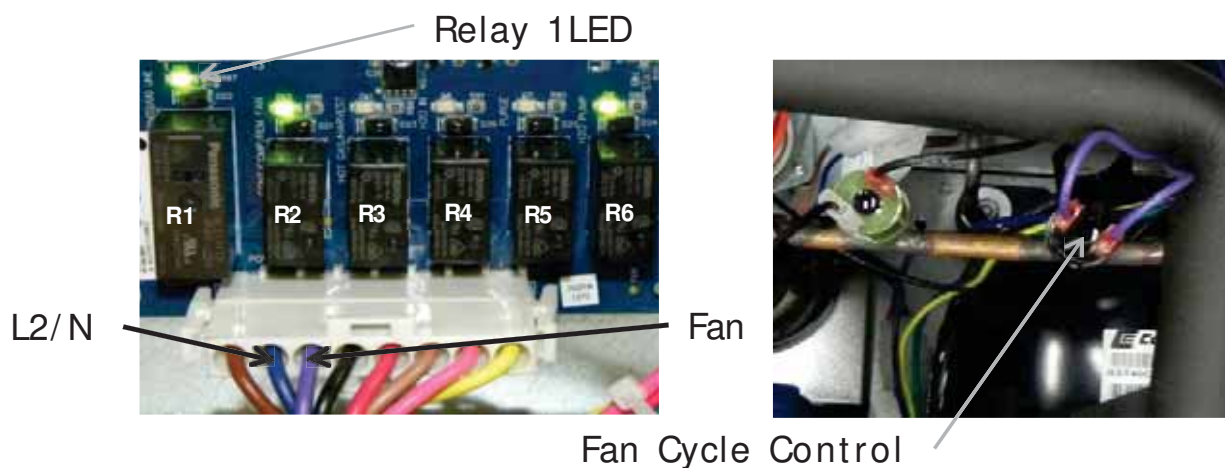

Evaporator

The nickel-plated Evaporator Assembly has a copper core to assure good heat transfer. Water is pumped gently over the Evaporator during the freeze cycle for even ice formation.



Evaporator Operation

The Evaporator should be fully flooded with refrigerant for most of the freeze cycle to ensure even ice formation. The serpentine on the back of the Evaporator starts at the bottom right corner of the plate (viewed from the front). The refrigerant lines run horizontally back and forth to the middle of the plate then rise along the left-hand side to the top. The line continues to “serpentine” downward to the middle of the plate and exit the Evaporator.

Troubleshooting

The Evaporator should always have a nickel appearance. Should the Evaporator have a “rust” color after a thorough cleaning, the plating may have come off and a replacement may be required. A dull “rainbow shimmer” may indicate an improper cleaner was used on the unit. Only approved Nickel Safe ice machine cleaner should be used.

An improper ice formation can be caused by a water or refrigeration issue.

A dirty water system can cause poor water flow over the Evaporator resulting in improper ice formation. See pg. 56 for Cleaning Instructions.

A refrigeration issue such as a low charge or restricted TXV could show on the Evaporator as ice forming on the bottom of the plate with thin to no ice forming on the top half. Verify refrigerant pressures on the Technical Specifications chart on pg. 60.

Should the ice slab resist coming off the plate, examine the Evaporator for loss of plating, pitting, mineral accumulation and/or loose horizontal dividers. Should any of the horizontal dividers separate from the base, replacement of the Evaporator is recommended.

Evaporator Drain

Located below the purge valve, a 3/8" diameter spout with a pop-it valve is installed on the back of the evaporator, connecting to the drain line. This design prevents water from flowing back into the evaporator during purging.

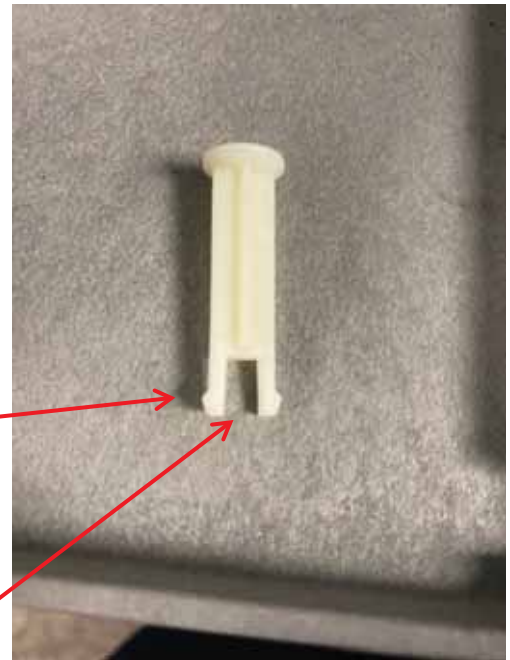
**Drain Spout****Ears****Pop-It Valve****Troubleshooting**

Remove the hose clamp and drain tube from the barbed spout. Verify that the pop-it is fully closing; if it is not, remove the pop-it and ensure the ears are positioned horizontally within the tube. Additionally, confirm that the spout is free from any obstructions.

Single Evaporator Plate Units

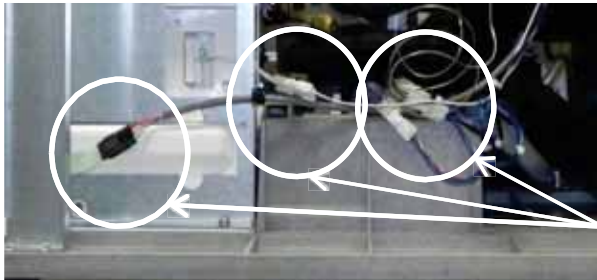

While recovering the refrigerant from the unit, disconnect High and Low Float Switches, Thermistor, Curtain Switch and Push Pad ribbon and move the wiring clear of the area.

Connectors

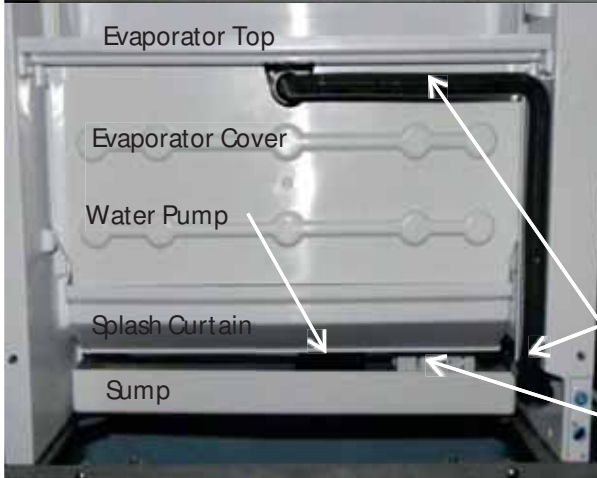

Remove the Splash Curtain, Evaporator Cover, Top Evaporator Cover, Water Distribution Tube, Water Pump Tube and its connector, Sump, Water Pump, and Float Switch Housing Assembly.

Water Pump Tube & Connector

Float Switch Housing



Harvest Assist Assembly



Purge Valve

On the rear of the Evaporator Assembly, disconnect Harvest Assist Assembly, Purge Valve and Purge Tube and remove from unit.



Cut Zip Ties

Remove 1/4" screws



Once unit is recovered, unsolder Evaporator refrigerant lines

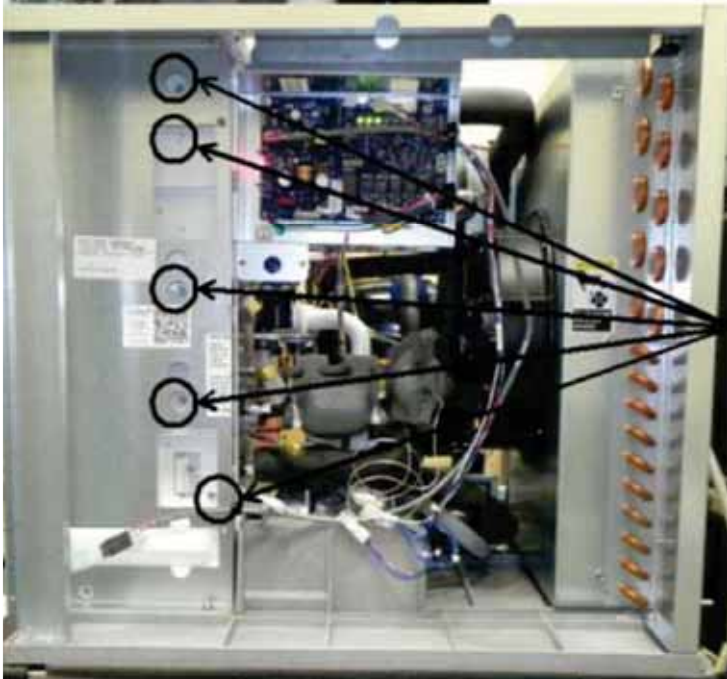

Remove 5) 1/4" screws securing Evaporator to surround on right hand side of unit.

Remove the right-hand side wall and discard. You will replace it with a new one that is provided in the kit.



Remove 2) 1/4" screws where frame meets The base on the left hand side of the unit.

The new evaporator comes with two new side wall pieces. For a single evaporator unit, you will only use the exterior right-side wall that comes in the kit to replace the existing right-side wall. This will allow the new evaporator to be installed without interfering with the plastics. It has cut outs to allow for the new refrigerant tube routing. For reference, see the image labeled "Exterior Right Wall" in the dual evaporator replacement section for correct part identification.



Surround

Pull the bottom of frame out to clear left-hand surround.

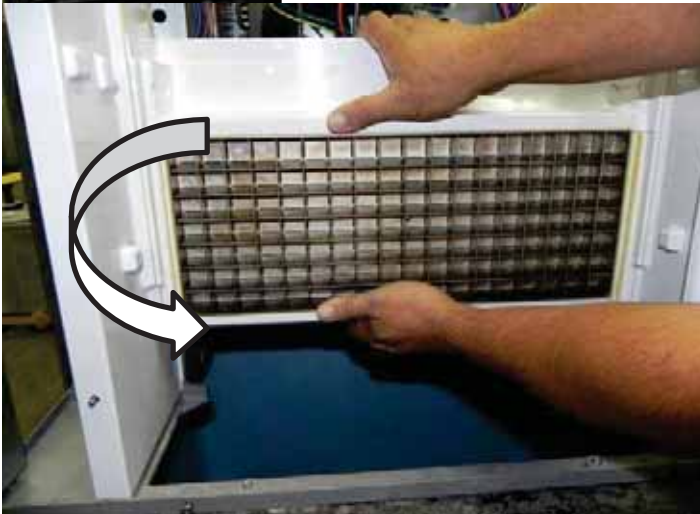

Grasp and remove Evaporator freeing the Left-Hand side first. The Left-Hand Surround will come out with the Evaporator; the Right-Hand Surround will be left in place. Once the Evaporator is out, separate the surround from the Evaporator by removing the five – 1/4" Screws on the Left-Hand side of the Evaporator. Remove Curtain Switch on Right Hand side of Evaporator and place on new Evaporator and mount Left Hand Side surround on new Evaporator.



Remove old silicone from base where shown in picture. Run a 3/8" bead of silicone included with Evaporator kit to replace existing where surround and Evaporator meet on the base.

Install Evaporator and reverse procedure for installation of components. Be sure to replace the Drier on all open system repairs.

When reinstalling screws into the base be sure to not exceed a torque of 30in-lb to avoid striping them.

48in Dual Plate Evaporator Units

Recover the refrigerant from the unit. During the recovery, disconnect curtain switch and push pad ribbon and move the wiring clear of the area. Remove the two mounting screws in the base of the unit near the curtain switch. Depending on the one being replaced remove the left or right-side screws.

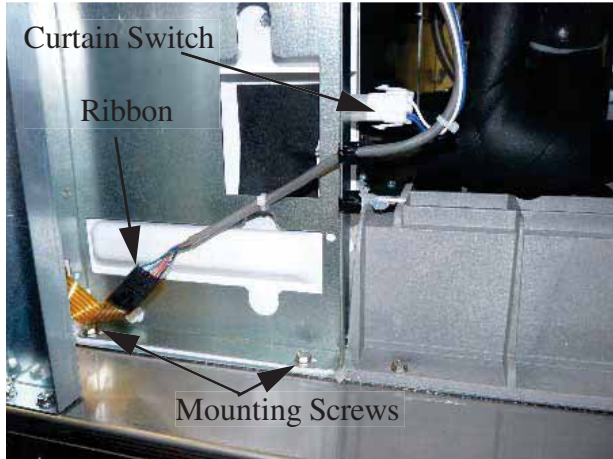

Right Side of Unit



Left Side of Unit

Remove the splash curtain, evaporator cover, top evaporator cover, water distribution tube, water pump tube and its connector, sump, water pump, and float switch housing assembly.

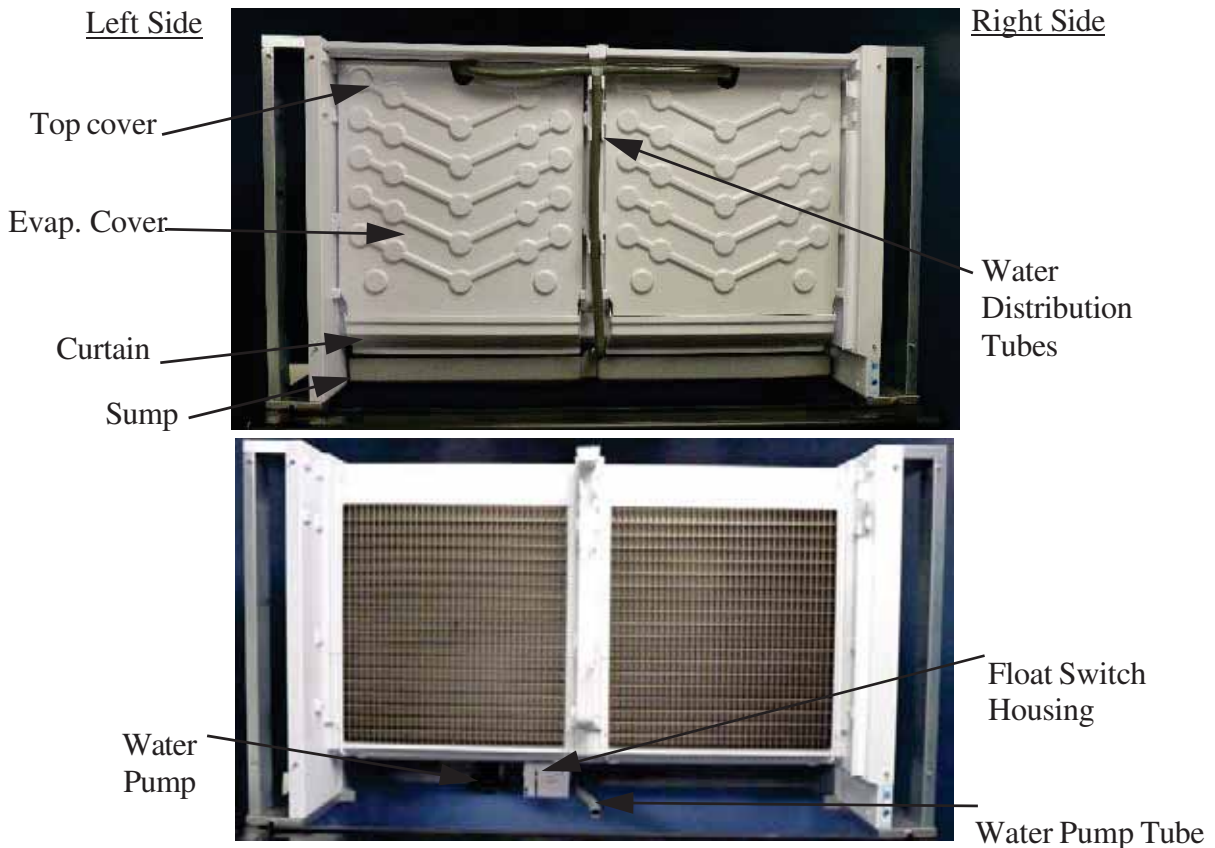

On the rear of the evaporator assembly, disconnect harvest assist assembly, purge valve and purge tube and remove from the unit. Note there are two harvest assists, one for each plate. Make sure you disconnect the proper one.

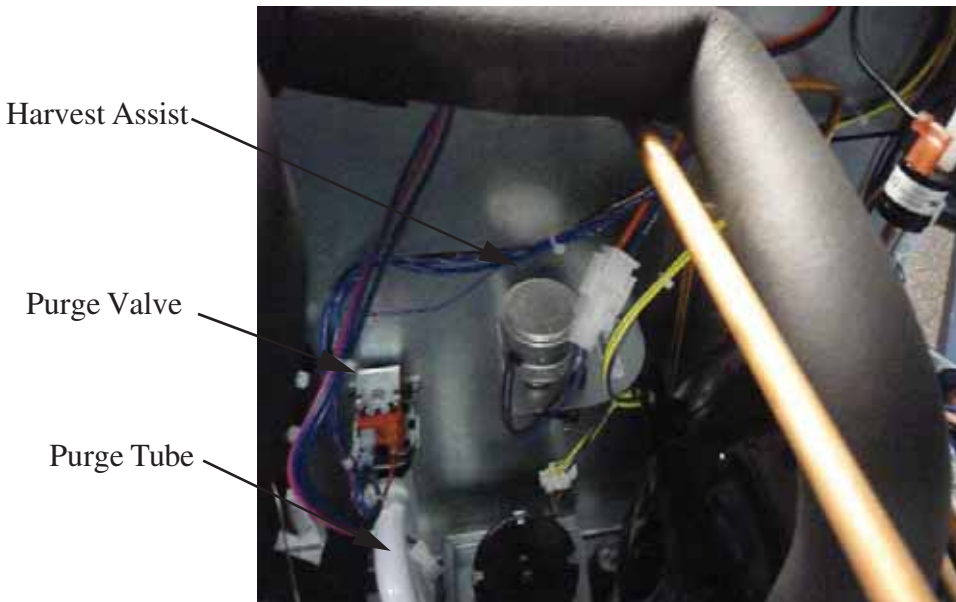

Once all the refrigerant is recovered. Remove the foam insulation from the evaporator plate tubing and Un-braze the evaporator tubes from the system so the plate is disconnected from the tubing system.

Remove the three 1/4" screws along the back side of the evaporator holding it to the base in the machine compartment.

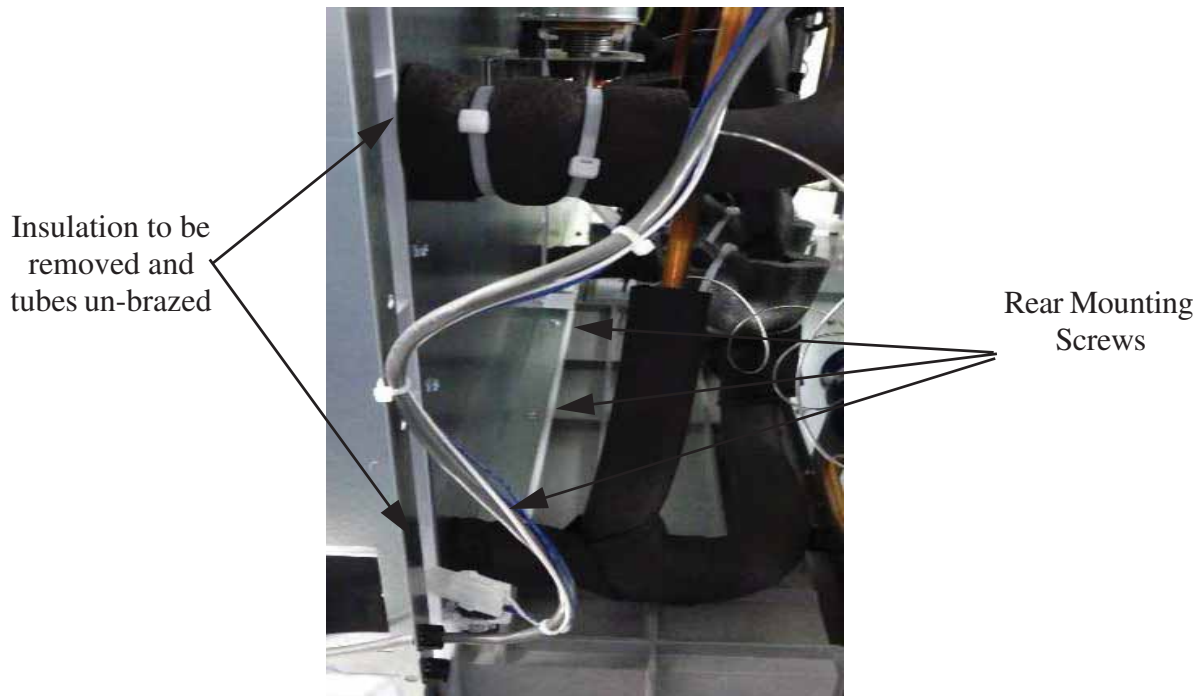

Drill out the rivets that are holding the top middle cross beam to have access to the two top rear mounting screws. Remove the corresponding screw to the evaporator you are working on.



With all the retaining screws out, and everything disconnected, you should now be able to rotate the plate out of position for replacement with the new evaporator.



The new evaporator comes with two new side wall pieces. If replacing the left evaporator plate, you will use the right interior wall. If replacing the right evaporator plate you will use the right-side wall. These new pieces have cut outs to accept the updated evaporator plate.



Interior Right Wall



Exterior Right Wall

There are five screws holding both side walls on to the evaporator assembly. Remove them and the side wall from the old assembly and reuse the screws to mount the new side walls to the new evaporator plate assemblies.

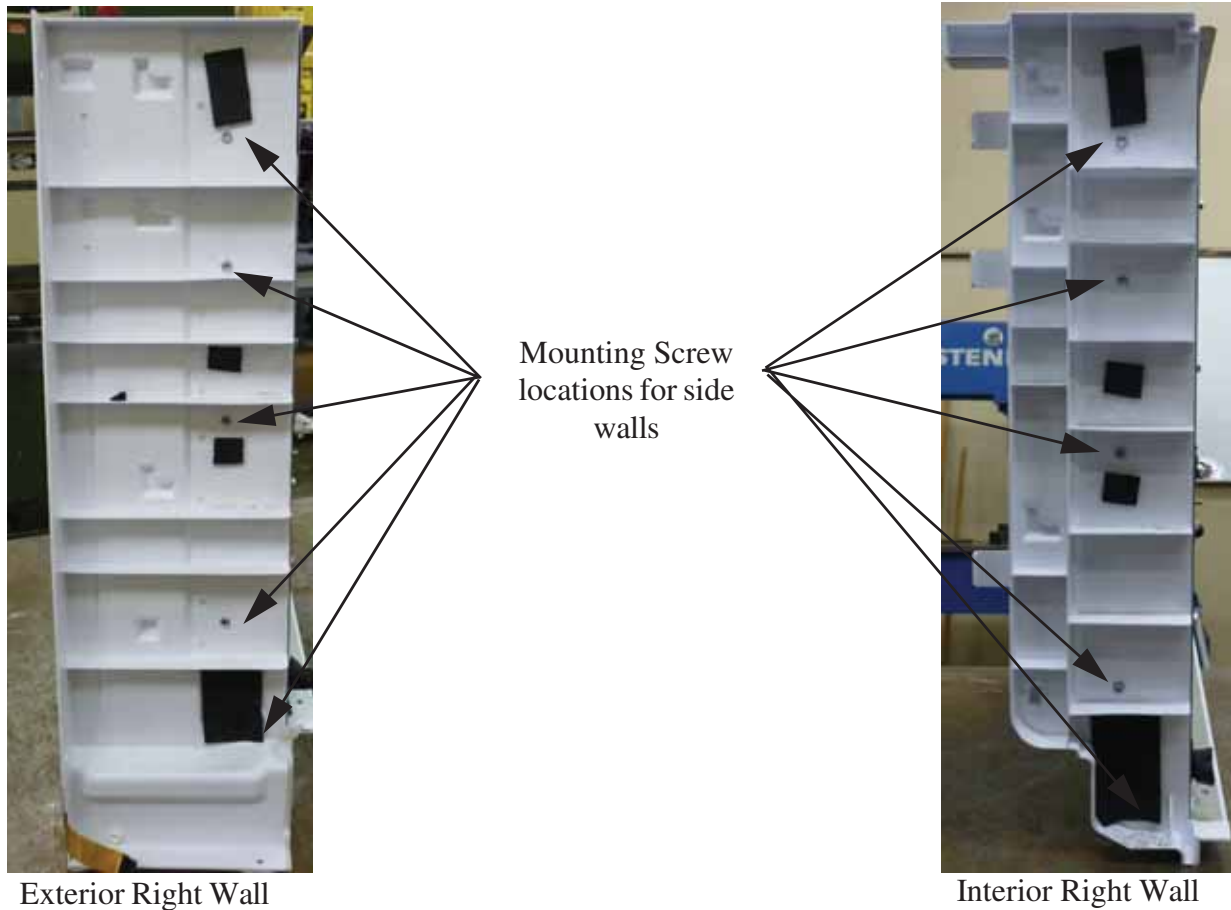

The left side walls from the old evaporators will be reused. Remove them from the old assemblies and reattach them to the new evaporator. Reuse the screws from the old assemblies. Remove the old silicone on the base where it interfaces with the evaporator. Add a new 3/8" bead of silicone to the corners and flat face of the base before reinstalling new evaporator.

Once you have the side walls attached to the new evaporator. Reinstall the assembly in the reverse order. When reinstalling screws into the base be sure to not exceed a torque of 30in-lb to avoid striping the base. Be sure to replace the filter dryer as well since it is an open system repair.

High Temp Safety (optional)

The High Temp Safety is a bi-metal thermostat strapped to the line at the outlet of the Hot Gas Valve. Should the Hot Gas Valve stick open, and the refrigerant line reach 180° F., the High Temp Safety would open, dropping power to the Contactor and shut down the Compressor. When the line temperature drops below 120° F., the contacts of the Safety will close, allowing power to the Contactor.

Note: 48" units have two high temp safety switches connected in series, should either hot gas circuit trigger a switch, it will shut down the compressor.

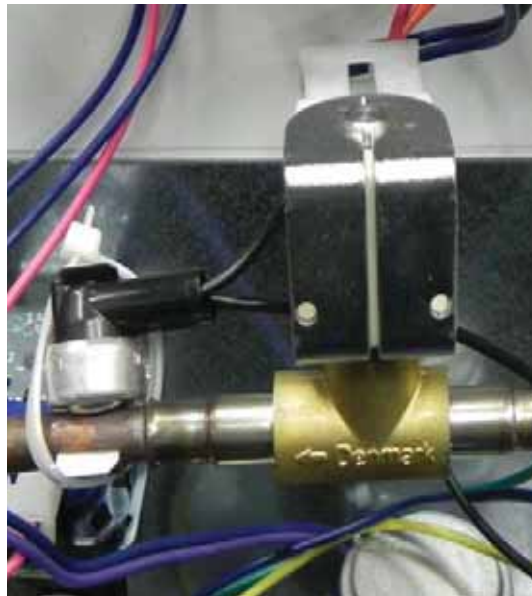

Troubleshooting

Should the Compressor not run with the R2 relay LED illuminated, verify if High Pressure Cutout is closed and Contactor coil is good. The discharge line from the Hot Gas Valve should be cool to the touch during a freeze cycle. With a line temperature below 120° F. (confirming hot gas valve is closed), the contacts in the High Temp Safety should be closed. Disconnect both leads of the High Temp Safety and check for continuity. If it open with a cool line, the safety will need to be replaced.

Refrigeration Section

The Refrigeration Section on a CIM Cuber contains the Compressor, Thermostatic Expansion Valve, Hot Gas Valve and Condenser. Remote systems also utilize a Mixing Valve (LAC), Liquid Line Solenoid and Receiver. *However, this section will vary as we Phase out R-404a and move to more environmentally friendly refrigerants including R-449a, and R-290 refrigerants.*

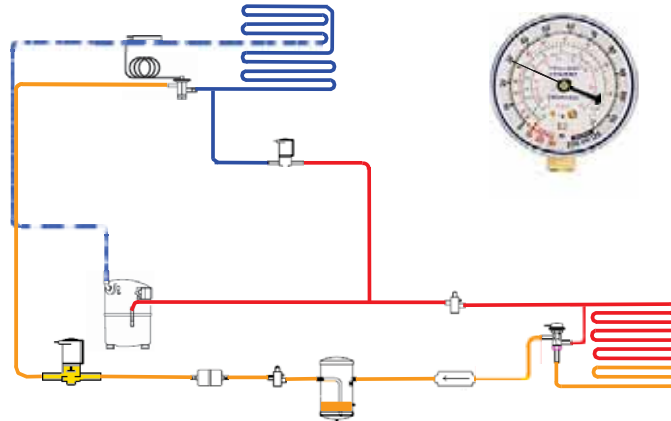

Refrigeration Section Operation

The Compressor drives the refrigeration system. Ice-O-Matic uses a Thermostatic Expansion Valve to control refrigerant flow through the Evaporator.

Troubleshooting - System

When troubleshooting the refrigeration system, always use stub gauges to limit the amount of refrigerant lost during connecting and disconnecting.

Always verify the refrigeration systems operating pressures when diagnosing any refrigeration component. The Compressor should pull within 10% of the RLA when measured 5 minutes into the Freeze Cycle and greater than 70% of RLA during the Freeze Cycle to be considered efficient.

Thermostatic Expansion Valve

The Thermostatic Expansion Valve meters refrigerant through the Evaporator.

Troubleshooting - Expansion Valve

First verify proper system pressures and charge. Verify the TXV bulb is securely mounted at 7 degrees off vertical (12:30 position) and well insulated. Generally, low suction pressure with a normal head pressure will show poor ice formation top to bottom on the Evaporator and indicate a low side restriction such as at the TXV. Should suction run high or not drop, verify bulb connection to suction line and look for sweating or frosting on the dome of the Compressor indicating TXV is stuck open.

Hot Gas Valve

The Hot Gas Solenoid Valve opens to provide gas to the Evaporator during the Harvest Cycle.

Troubleshooting - Hot Gas Valve

Should the valve not open at the initiation of the Harvest Cycle (R3 LED ON), verify voltage at the coil of the solenoid. If no voltage is present, verify Molex is properly connected at Board and Voltage is present at Molex. If Voltage is present at coil, verify resistance through coil. If the coil shows open, replace the coil. If the coil checks out, place magnetic donut on top of coil. If valve will not open, replace the Hot Gas Valve body. Should suction pressure run high, check the temperature of the inlet and outlet line of the Hot Gas Valve. It should be greater than 10-degree F. different. If less than 10 degrees F., the Valve is leaking and should be replaced. (See also pg. 54.)

Liquid Line Solenoid

The Liquid Line Solenoid opens to allow refrigerant to flow from the Receiver on Remote Systems. It is energized by R1 along with Remote Fan Motors. Diagnosis of Liquid Line Solenoid is much the same as the Hot Gas Solenoid Valve (see above.)

Mixing Valve

The 220 psig. Mixing Valve (or LAC) Is used to maintain head pressure in low ambient.

Troubleshooting - Mixing Valve

In lower ambient temperatures, the Mixing Valve bypasses the Condenser to maintain head pressure. During bypass mode, the inlet and outlet lines at the Condenser are at the same temperature. In warmer ambient conditions, the Mixing Valve directs refrigerant to the Condenser Coil, resulting in an approximate 20°F temperature difference. A low charge is indicated by hot inlet and outlet lines at the Condenser and a hot Receiver. It is important to verify the system charge before determining if the Mixing Valve is faulty.

R-290 Troubleshooting

R-290 is an A3 refrigerant, which refers to refrigerant grade propane (pure), a substance that is odorless, highly flammable and displaces air as it is heavier than air. This refrigerant has been used in the industry for several years. Specific precautions should be taken when handling R-290. Since R-290 is flammable, work in an open, well-ventilated area.



Use appropriate tools to ensure safety.

- Combustible gas leak detector
- Tubing cutters
- Pinch-off tool
- Voltmeter
- Amp meter
- Temperature clamp probes
- Schrader taps
- Combustible gas Warning signs
- Refrigerant scale
- Vacuum pump
- Nitrogen
- R290 Temperature pressure Chart



All of the components work the same. But testing of the refrigeration section will be a little different. Pressure will not be tested until the last resort as these units are critically charged.

Using a temperature pressure chart you can determine approx. pressure.

Measuring compressor amperage can show workload of the compressor to determine if the charge is correct, restriction, or compressor performance. High amperage could be indicative of dirty condenser coils, condenser fan motor, compressor beginning to fail, or low voltage to the compressor.

Low amperage could be a compressor motor weak or failing, low refrigerant charge, restriction, or the valves in compressor not pumping

Using temperature clamps txv operation, hot gas valve operation, evaporator performance, and condenser performance can be determined.

Units are sealed no Schrader ports and will need to be resealed after and refrigeration service.

Explanation of Refrigeration System

Understanding Freeze and Harvest Cycles in Ice Machines

The diagram referenced illustrates the flow of refrigerant through an ice machine's components during both freeze and harvest cycles. For R-290 machine trouble shooting

Freeze Cycle

During the freeze cycle, refrigerant circulates from the compressor to the condenser via the discharge line. In the condenser, heat exchange occurs: hot, high-pressure gas releases its heat into the air and condenses into a warm, high-pressure liquid. This liquid proceeds through the thermal expansion valve (TXV), which meters the flow, resulting in a cool, low-pressure liquid. As this refrigerant absorbs heat from the water at the evaporator, it transforms into a cool, low-pressure gas, which is then drawn back to the compressor, completing the loop. The temperature and pressure can be checked at various points—evaporator and condenser inlets and outlets—can be matched with a temperature-pressure chart for diagnostic purposes.

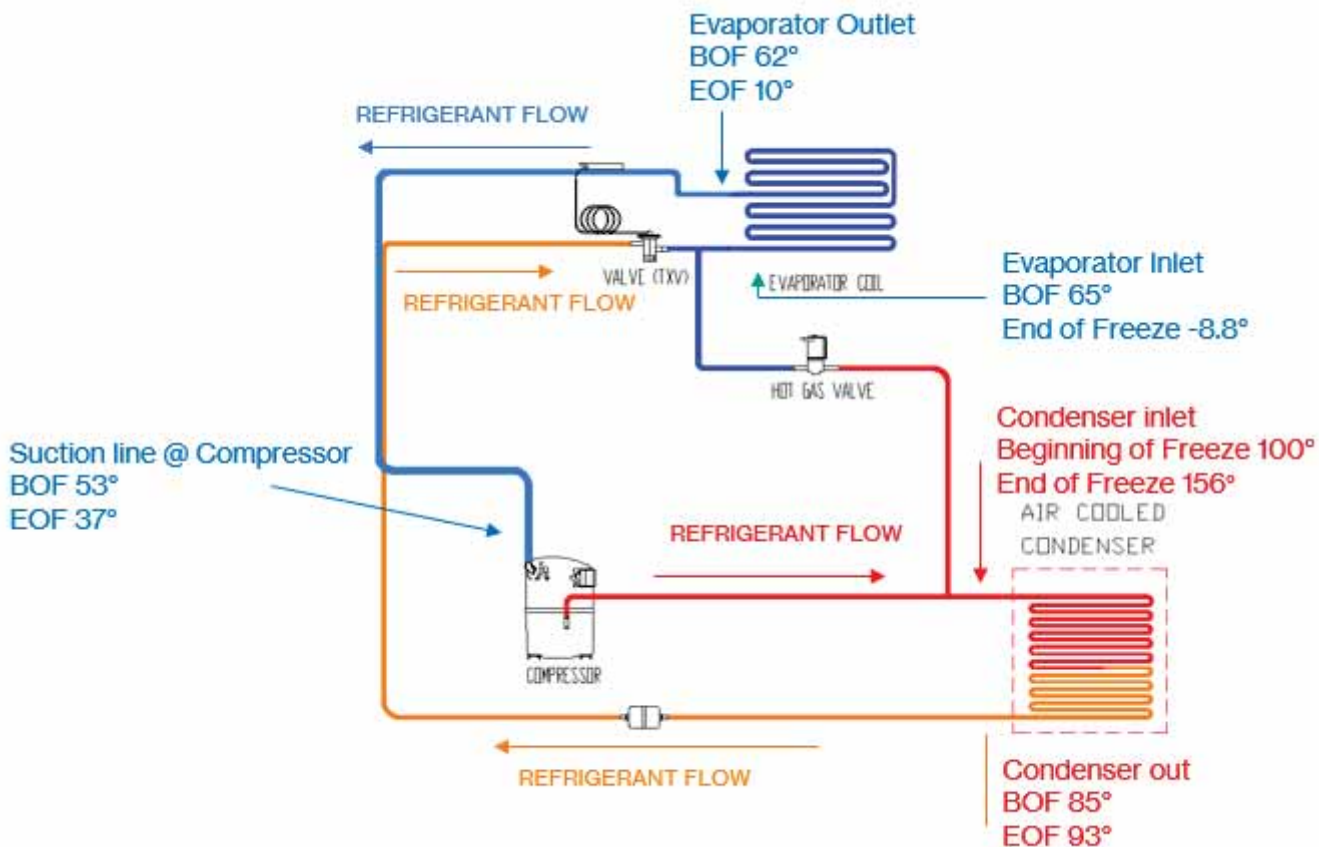

Harvest Cycle

In the harvest cycle, the hot gas valve opens, redirecting hot, high-pressure gas directly to the evaporator. This sudden influx of heat raises the plate temperature above freezing, allowing ice to be released from the plates. At this stage, the mixture of hot gas and cool liquid from the TXV ensures an efficient harvest. Proper timing is crucial; if the harvest phase is too prolonged, it can cause overheating or lead to liquid flooding in the compressor, which may damage the system.

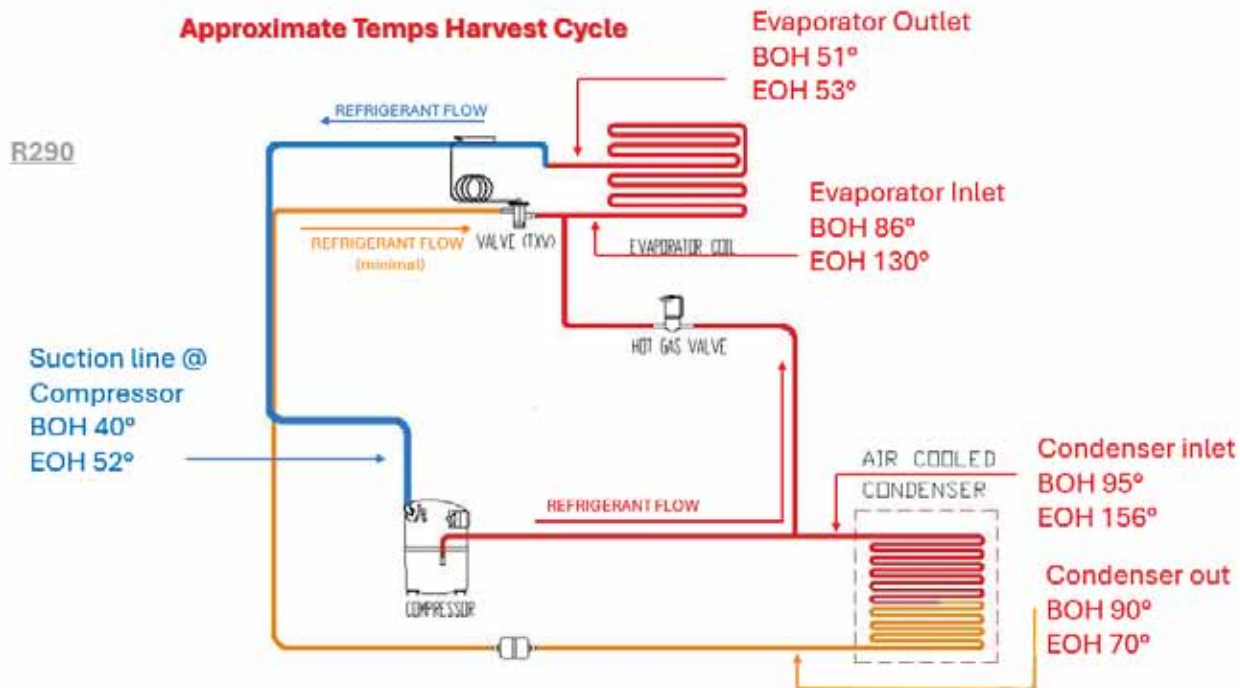

Key Diagnostic and Maintenance Points

- Temperature-pressure charts help estimate system pressures for troubleshooting.
- Compressor amperage readings indicate if the compressor is working properly or if there are issues such as restrictions, low charge, or failing components.
- Units are critically charged and sealed, lacking Schrader ports, so testing pressures is a last resort.
- Routine cleaning and maintenance, especially of the condenser and ice-making sections, are vital for reliable operation and to maintain warranty coverage.

These diagrams help the technicians to assess performance and diagnose problems by following the refrigerant's path and monitoring system temperatures and pressures. Understanding the freeze and harvest cycles enables efficient troubleshooting and ensures the longevity of the ice machine.

General Maintenance**⚠ WARNING**

Electrical shock and/or injury from moving parts inside this machine can cause serious injury. Disconnect electrical supply to machine prior to performing any adjustments or repairs.

Failure to perform the required maintenance at the frequency specified will void warranty coverage in the event of a related failure.

General Maintenance Procedure

To ensure economic, trouble-free operation of your machine, it is recommended that the following maintenance be performed every 6 months.

1. Clean the ice-making section per the instructions below. Cleaning should be performed at a minimum of every 6 months. Local water conditions may require that cleaning be performed more often.
2. Check ice bridge thickness. See page 14 for proper thickness and adjustment procedure.
3. Check water level in Sump. See page 47 for proper water level and adjustment procedure.
4. Clean the condenser (air-cooled machines) to ensure unobstructed air flow.
5. Check for leaks of any kind: water, refrigerant, oil, etc.
6. Check the bin control switch (if applicable) for proper adjustment.
7. Check the Water Regulating Valve (water cooled machine) for proper adjustment by measuring the discharge pressure which should be adjusted to maintain 250 psi (17.01 bar/ 1.723 MPa). Adjust the water regulating valve as required. Water exiting the condenser should be between 100°F (38°C) and 110°F (43°C).
8. Check all electrical connections.
9. Oil the fan motor if the motor has an oil fitting. (Self-contained air-cooled models only)
10. Check the water filter (if applicable) and replace it if dirty or restricted
11. Inspect the evaporator water distribution tube to insure even distribution of water across the face of the evaporator.
12. Clean Remote Condenser if applicable.

Cleaning and Sanitizing

Cleaning Instruction for Ice-O-Matic CIM Series Ice Machines

Note: Proper cleaning of an ice machine requires two parts: descaling and sanitizing.

Descaling should be scheduled at a minimum of twice per year but no more than once per month.

Descaling dissolves the mineral deposits on the evaporator and other surfaces. It removes scale, calcium, lime scale and other mineral buildup. Ice-O-Matic requires a “nickel-safe” cleaner such as Nu-Calgon Nickel-Safe Ice Machine Cleaner or equivalent diluted per manufacturer’s instructions.

Sanitizing should be performed after each descaling but no more than once per month.

Sanitizing disinfects the machine and removes microbial growth including mold and slime. Ice-O-Matic requires a “nickel-safe” sanitizer such as Nu-Calgon IMS-III or equivalent diluted per manufacturer’s instructions.

Please refer to www.iceomatic.com for approved chemical formulations and proper pH balance.

CAUTION: Do not mix cleaner (descaler) and sanitizer together.

Eye protection is recommended when handling descaler or sanitizer.

Wear protective rubber gloves when handling descaler or sanitizer.

Note: Electrical power will be ON when performing the following cleaning instructions.

1. Remove all ice from storage means to prevent any contamination of ice in storage.
2. Remove the front panel of the ice machine by loosening the two front panel screws with a Phillips head screwdriver. Lift panel to remove.
3. Press and hold the POWER button for 3 seconds to initiate a harvest cycle (blue light will begin to flash for Manual Harvest mode). This ensures there is no ice on the plate and the water is emptied from the sump.

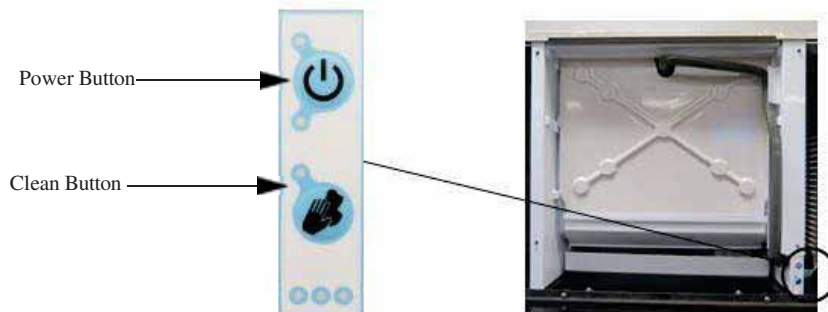

4. Once the ice machine has completed its harvest cycle, the POWER light will go to solid red (OFF mode).
5. Remove the upper evaporator cover and leave the lower curtain.

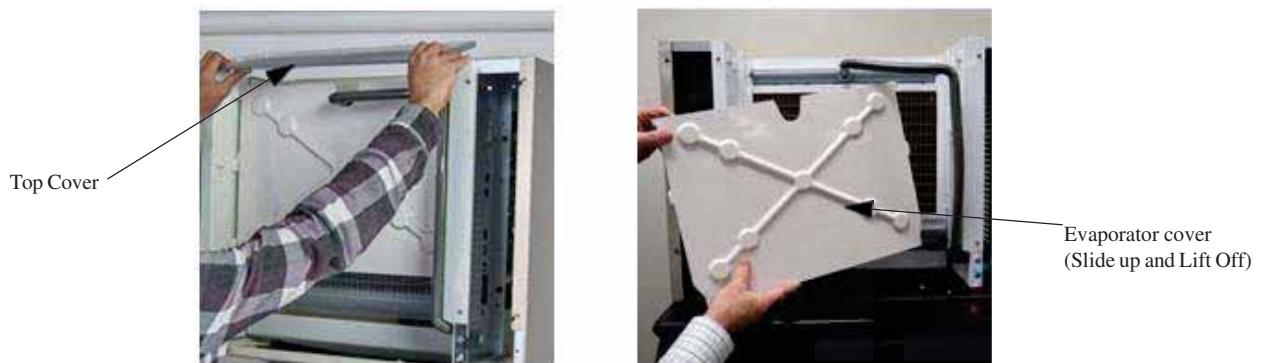

6. Quick press the CLEAN button to start the process. The ice machine will show a solid red and flashing yellow light during the cleaning cycle. Units cannot be brought out of clean mode once clean mode is started.
7. The machine will first verify that the sump is empty with the pump ON, and the purge valve energized.
8. When the sump is mostly empty, the machine will begin to fill the sump (about 30 seconds to a minute).
9. The pump turns ON when the water fill reaches the proper fill level. Measure the appropriate amount of descaler according to the machine size and sump volume from chart below. Carefully pour the descaler into the sump using the lower curtain to prevent splash. Replace the upper evaporator cover.

Model	Sump Size (volume) Gallons (in liters)	Example: Nu-Calgon Nickel-Safe Ice Machine Cleaner Descaler Concentration Ratio 5 fl.oz. per 1 gal. of water (39 mL per 1 Liter of water)	Example Nu-Calgon IMS-III Sanitizer Concentration Ratio 1.6 fl. oz. per 1 gal. of water (12.5 mL per 1 Liter of water)
CIM0320/0330	.9 (3.4)	Add 4.5 fl. oz. (133mL)	Add 1.5 fl. oz. (44mL)
CIM0430/0520/0530/0630	1.2 (4.5)	Add 6 fl. oz. (177mL)	Add 2 fl. oz. (59mL)
CIM0820/0830/1120/1130	1.1 (4.2)	Add 5.5 fl. oz. (164mL)	Add 1.8 fl. oz. (53mL)
CIM1440/1540/1840/2040	1.8 (6.8)	Add 9.0 fl. oz. (265mL)	Add 2.9 fl. oz. (85mL)



10. The machine will remain in the WASH cycle for 15 minutes.
11. After WASH time, the machine will PURGE and re-fill with the water pump ON.
12. The machine will RINSE (less than one minute) then repeat PURGE/FILL/RINSE multiple times.
13. The machine will end the cleaning cycle with a mostly empty sump and a solid red and yellow light.
14. Quick press the CLEAN button to return to OFF mode.
15. Remove the upper evaporator cover and lower evaporator curtain. Using a solution with the proper concentration of cleaner (descaler or sanitizer), wipe down with a clean, soft cloth the evaporator, water spillway, water distributor, upper evaporator cover, lower evaporator curtain and all splash surfaces. Verify that all residue and residual minerals have been removed.
16. If a full clean of water components is required, this can be done by referring to the service manual for water system component breakdown. This is recommended to be done by a qualified service agent.
17. Re-assemble all ice machine water system components in reverse order.
18. Sanitizing the ice machine is recommended after descaling. Repeat the process with sanitizer at the correct ratio.
19. It is recommended to clean (descale and sanitize) the storage means after cleaning the ice machine.
20. Quick press the POWER button to return the ice machine to the ice making cycle.
21. Replace the front panel and tighten the two panel screws with a Phillips screwdriver.

Cabinet Care

Chemicals for Descaling and Sanitizing

It is important to use solutions that do not harm the ice machine. Never use cleaning or sanitizing solutions that contain Nitric Acid, Sulfuric Acid, Hydrochloric Acid, Carboric Acid, Acetic Acid, diluted Acetic Acid or non-food-grade vinegar (concentration of acetic acid greater than 6% and does not contain enzymes created in processing) or any chlorine-based solution such as bleach, chlorine dioxide or any type of salts such as potassium chloride (potassium salts) or sodium chloride. Check the label or the manufacturer's Material Safety Data Sheet (MSDS) to be sure. These chemicals can attack the surface of the evaporator as well as other metal components causing corrosion and flaking. **Using the incorrect cleaner or sanitizer will void the warranty of the unit**

Please refer to www.iceomatic.com for approved chemical formulations and proper pH balance.

Cleaning Stainless Steel and Aluminum

Commercial grades of stainless steel and aluminum are susceptible to rusting or corrosion if not properly maintained. It is important that you properly care for the stainless steel and aluminum surfaces of your ice machine and bin to avoid the possibility of rust or corrosion.

Use the following recommended guidelines for keeping your machine looking like new:

1. **Clean the stainless steel and aluminum thoroughly once a week.** Clean frequently to avoid the build-up of hard, stubborn stains. Hard water stains left to sit can weaken the metals corrosion resistance and lead to rust or corrosion. Use a nonabrasive cloth or sponge, working with, not across, the grain.
2. **Do not use abrasive tools to clean the metal surface.** Do not use steel wool, abrasive sponge pads, wire brushes or scrapers to clean the metal.
3. **Do not use cleaners that use chlorine or chlorides.** Do not use chlorine bleach products to clean the metal surfaces. Chlorides break down the metals protective layer.
4. **Rinse with clean water.** If chlorinated cleansers are used, you must thoroughly rinse the surface with clean water and wipe dry immediately.
5. **Use the right cleaning agent.** The table below lists the recommended cleaning agents for common metal cleaning problems.

Cleaning Activity	Cleaning Agent	Method of Application
Routine Cleaning	Mild dish soap, ammonia, glass cleaner, or mild detergent with water. Household kitchen cleaning chemicals approved for metal surfaces.	Apply with clean cloth or sponge. Rinse with clean water and wipe dry.
Removing grease or fatty acids	Oven cleaners	Apply generously; allow to stand for 15-20 minutes. Rinse with clean water. Repeat as required.
Removing hard water spots and scale	Vinegar	Swab or wipe with clean cloth. Rinse with water and wipe dry.

Winterizing Procedures

IMPORTANT: Whenever the ice machine is taken out of operation during the winter months, the procedure below must be performed. Failure to do so may cause serious damage and will void all warranties.

1. Turn off water to machine.
2. Make sure all ice is off of the evaporator(s). If ice is being made, initiate harvest by pressing the Power Button for approximately 3 seconds. The unit will shut off automatically following the harvest.
3. Disconnect the tubing between the water pump discharge and water distribution tube and drain any water.
4. On water cooled machines, hold the water regulating valve open by prying upward on the water valve spring with a screwdriver while using compressed air to blow all the water out of the condenser.

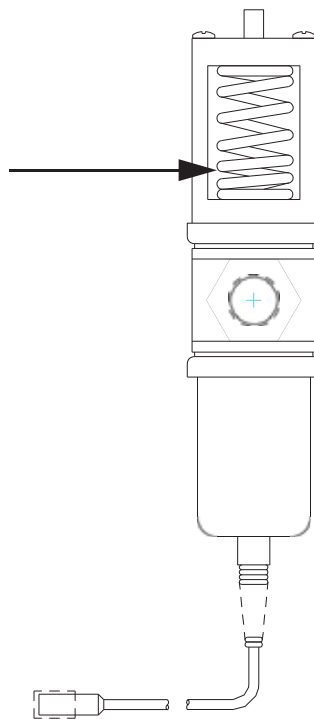

5. Remove all of the ice in the storage bin and discard.

Technical Specifications

Model	Voltage/ Hz/ Phase	Approx. Suction Press	Approx. Head Press	Avg. Batch Half/ Full	Approx. Cycle Time 90/ 70 in Min.	Avg. Water Usage per 100 lbs. Produced in Gallons		Min Circuit Amps	Max Fuse size	kWH Used	Comp. LRA	Comp. RLA	Ref. Type	Charge in ounces
						Potable	Water Cond.							
CIM 0320A	115/60/1	50-30	175-400	3.025/3.375	18-23	20.0		11.0	15	6.69	50.0	8.1	R-404a	20
CIM 0320W	115/60/1	50-30	250	3.025/3.375	16-21	19.6	179	10.7	15	5.19	50.0	8.1	R-404a	13
CIM 0320A90	115/60/1	45-15	175-245	3.025-3.375	15-23	19.0		11.4	15	5.81	44.0	8.3	R-290	4.94
CIM 0325A	220-240/ 50/1	50-30	175-400	3.025/3.375	19-24	22.0		6.9	16	7.32	29.5	5.1	R-404a	22
CIM 0325W	220-240/ 50/1	50-30	250	3.025/3.375	16-21	20.0	187.5	6.8	16	5.53	29.5	5.1	R-404a	13
CIM 0326A	208-230/ 60/1	50-30	175-400	3.025/3.375	18-23	24.0		6.5	15	6.8	26.5	4.6	R-404a	22
CIM 0330A	115/60/1	50-30	175-400	3.025/3.375	18-23	20.0		11.0	15	6.69	50.0	8.1	R-404a	20
CIM 0330W	115/60/1	50-30	250	3.025/3.375	16-21	19.6	179	10.7	15	5.19	50.0	8.1	R-404a	13
CIM 0330A90	115/60/1	45-15	175-245	3.025-3.375	16-21	19.0		11.4	15	5.81	44.0	8.1	R-290	4.94
CIM 0335A	220-240/ 50/ 1	50-30	175-400	3.025/3.375	19-24	22.0		6.9	16	7.32	29.5	5.1	R-404a	22
CIM 0430A	115/60/1	50-30	175-400	5.025/5.65	22-26	19.8		11.0	15	5.43	50.0	8.1	R-404a	24
CIM 0430W	115/60/1	50-30	250	5.025/5.65	19-22	17.8	169	10.7	15	4.75	50.0	8.1	R-404a	14
CIM 0430A90	115/60/1	45-15	175-245	5.025-5.65	16-21	17.0		11.4	15	4.95	44.0	8.3	R-290	4.94
CIM 0435A	220-240/ 50/1	50-30	175-400	5.025/5.65	20-24	20.0		8.7	16	5.97	37.0	6.3	R-404a	24
CIM 0436A	115/60/1	50-30	175-400	5.025/5.65	17-20	18.0		6.3	15	5.46	26.5	4.6	R-404a	24
CIM 0436W	115/60/1	50-30	250	5.025/5.65	20-24	17.7	185	6.1	15	4.37	26.5	4.6	R-404a	14
CIM 0520A	115/60/1	50-30	175-400	5.025/5.65	18-22	19.9		17.8	30	5.87	70.0	13.5	R-404a	20
CIM 0520W	115/60/1	50-30	250	5.025/5.65	15-18	20.0	181	17.4	30	4.7	70.0	13.5	R-404a	14
CIM 0520A90	115/60/1	45-15	175-245	5.025/5.65	16-21	17.0		11.9	20	5.43	55.0	8.7	R-290	4.59
CIM 0525A	220-240/ 50/1	50-30	175-400	5.025/5.65	18-21	20.0		11.2	16	6.11	38.0	8.5	R-404a	22
CIM 0525W	220-240/ 50/1	50-30	250	5.025/5.65	15-18	19.5	190	11.0	16	5.00	38.0	8.5	R-404a	14
CIM 0526A	208-230/ 60/1	50-30	175-400	5.025/5.65	17-21	20.0		8.2	15	5.02	33.7	6.1	R-404a	22
CIM 0530A	115/60/1	50-30	175-400	5.025/5.65	18-22	19.9		17.8	30	5.87	70.0	13.5	R-404a	20
CIM 0530W	115/60/1	50-30	250	5.025/5.65	15-18	20.0	181	17.4	30	4.7	70.0	13.5	R-404a	14
CIM 0530A90	115/60/1	45-15	175-245	5.025/5.65	16-21	17.0		11.9	20	5.43	55.0	8.7	R-290	4.59
CIM 0530R49	115/60/1	45-25	220-400	5.025/5.65	17-21	17.0		20.1	30	5.08	70.0	15	R-449a	125
CIM 0530R	115/60/1	50-30	220-400	5.025/5.65	17-21	19.6		20.1	30	6.21	70.0	13.5	R-404a	132
CIM 0535A	220-240/ 50/1	50-30	175-400	5.025/5.65	18-21	20.0		11.2	16	6.11	38.0	8.5	R-404a	22
CIM 0535W	220-240/ 50/1	50-30	250	5.025/5.65	16-19	19.5	190	11.0	16	5	38.0	8.5	R-404a	13
CIM 0535R	220-240/ 50/1	50-30	220-400	5.025/5.65	17-20	20.0		12.0	20	6.31	38.0	8.5	R-404a	132
CIM 0635A	220-240/ 50/1	50-30	175-400	5.025/5.65	16-19	20.0		8.1	16	5.72	37.0	5.8	R-404a	22
CIM 0636A	208-230/ 60/1	50-30	175-400	5.025/5.65	16-19	18.6		9.2	15	5.63	46.0	6.9	R-404a	20
CIM 0636W	208-230/ 60/1	50-30	250	5.025/5.65	14-16	19.2	180	9.0	15	4.27	46.0	6.9	R-404a	14
CIM 0636A90	208-23/ 60/1	45-15	175-245	5.025/5.65	16-21	17.0		8.1	15	4.53	35.0	6.0	R-290	4.94
CIM 0636R49	208-230/ 60/1	45-25	220-400	5.025/5.65	14-16	18.5		15	15	5.20	46.0	7.7	R-449a	125

Model	Voltage/ Hz/ Phase	Approx. Suction Press	Approx. Head Press	Avg. Batch Half/ Full	Approx Cycle Time 90/ 70in Minutes	Avg. Water Usage per 100 lbs. Produced in Gallons		M in Circuit Amp.	Max Fuse size	kWH Used	Comp. LRA	Comp. RLA	Ref. Type	Charge in ounces
						Potable	Water Cond.							
CIM0636R	208-230/ 60/ 1	50-30	220-400	5.025/ 5.65	14-16	19.0		10.0	15	5.29	46	6.9	R-404a	132
CIM0825A	220-240/ 50/ 1	50-30	175-400	7.15/ 8.10	17-21	18.0		13.3	20	4.73	55.0	9.7	R-404a	40
CIM0825R	220-240/ 50/ 1	50-30	220-400	7.15/ 8.10	15-18	18.0		13.7	20	4.38	55.0	9.7	R-404a	176
CIM0826A	208-230/ 60/ 1	50-30	175-400	7.15/ 8.10	17-20	19.0		13.4	20	5.0	56.0	9.8	R-404a	40
CIM0826A49	208-230/ 60/ 1	45-25	175-400	7.15/ 8.10	17-20	17.5		13.3	20	4.69	56.0	9.8	R-449a	40
CIM0826W	208-230/ 60/ 1	50-30	250	7.15/ 8.10	17-20	19.0	140	12.8	20	4.2	56.0	9.8	R-404a	30
CIM0826R	208-230/ 60/ 1	50-30	220-400	7.15/ 8.10	16-19	19.0		13.8	20	4.9	56.0	9.8	R-404a	176
CIM0826R49	208-230/ 60/ 1	45-25	220-400	7.15/ 8.10	16-19	17.5		13.7	20	4.69	56.0	9.8	R-449a	176
CIM0835A	220-240/ 50/ 1	50-30	175-400	7.15/ 8.10	16-19	18.0		13.3	20	4.73	55.0	9.7	R-404a	40
CIM0835GA	220-240/ 50/ 1	50-30	175-400	8.6	17-20	18.0		15.2	20	5.7	58.0	11.2	R-404a	38
CIM0835W	220-240/ 50/ 1	50-30	250	7.15/ 8.10	16-19	18.0	110	12.7	20	3.96	55.0	9.7	R-404a	28
CIM0835R	220-240/ 50/ 1	50-30	220-400	7.15/ 8.10	16-19	18.0		13.7	20	4.38	55.0	9.7	R-404a	176
CIM0836A	208-230/ 60/ 1	50-30	175-400	7.15/ 8.10	16-19	19.0		13.4	20	5	56.0	9.8	R-404a	40
CIM0836A49	208-230/ 60/ 1	45-25	175-400	7.15/ 8.10	16-19	17.5		13.3	20	4.69	56.0	9.8	R-449a	40
CIM0836W	208-230/ 60/ 1	50-30	250	7.15/ 8.10	16-19	19.0	140	12.8	20	4.2	56.0	9.8	R-404a	30
CIM0836R	208-230/ 60/ 1	50-30	220-400	7.15/ 8.10	16-19	19.0		13.8	20	4.9	56.0	9.8	R-404a	176
CIM0836R49	208-230/ 60/ 1	45-25	220-400	7.15/ 8.10	16-19	18.0		13.8	20	4.69	56.0	9.8	R-449a	40
CIM0836GA	208-230/ 60/ 1	50-30	175-400	8.6	17-20	19.0		13.9	20	5.4	78.0	10.2	R-404a	38
CIM1125A	220-240/ 50/ 1	50-30	175-400	7.15/ 8.10	16-19	18.0		15.2	25	5.2	58.0	11.2	R-404a	36
CIM1125R	220-240/ 50/ 1	50-30	220-400	7.15/ 8.10	11-15	18.0		15.6	25	4.6	58.0	11.2	R-404a	176
CIM1126A	208-230/ 60/ 1	50-30	175-400	7.15/ 8.10	11-15	19.0		13.9	20	5.1	78.0	10.2	R-404a	40
CIM1126A49	208-230/ 60/ 1	45-25	175-400	7.15/ 8.10	11-15	18.0		13.8	20	4.69	78.4	10.2	R-449a	40
CIM1126W	208-230/ 60/ 1	50-30	250	7.15/ 8.10	11-15	19.0	140	13.3	20	4.1	78.0	10.2	R-404a	32
CIM1126R	208-230/ 60/ 1	50-30	220-400	7.15/ 8.10	11-15	19.0		14.3	20	5.1	78.0	10.2	R-404a	176
CIM1126R49	208-230/ 60/ 1	45-25	220-400	7.15/ 8.10	11-15	18.0		13.8	20	4.75	78.4	10.2	R-449a	176
CIM1135A	220-240/ 50/ 1	50-30	175-400	7.15/ 8.10	11-15	18.0		15.2	25	5.2	58.0	11.2	R-404a	36
CIM1135W	220-240/ 50/ 1	50-30	250	7.15/ 8.10	11-15	18.0	110	14.6	25	4.2	58.0	11.2	R-404a	32
CIM1135R	220-240/ 50/ 1	50-30	220-400	7.15/ 8.10	11-15	18.0		15.6	25	4.6	58.0	11.2	R-404a	176
CIM1136A	208-230/ 60/ 1	50-30	175-400	7.15/ 8.10	11-15	19.0		13.9	20	5.1	78.0	10.2	R-404a	40
CIM1136W	208-230/ 60/ 1	50-30	250	7.15/ 8.10	11-15	19.0	140	13.3	20	4.1	78.0	10.2	R-404a	32

Model	Voltage/ Hz/ Phase	Approx. Suction Press	Approx. Head Press	Avg. Batch Half/ Full	Approx Cycle Time 90/ 70in Minutes	Avg. Water Usage per 100 lbs. Produced in Gallons		Min Circuit Amp.	Max Fuse size	kWH Used	Comp. LRA	Comp. RLA	Ref. Type	Charge in ounces
						Potable	Water Cond.							
CIM 1136R	208-230/ 60/ 1	50-30	220-400	7.15/ 8.10	11-15	19.0		14.3	20	5.1	78.0	10.2	R-404A	176
CIM 1136R49	208-230/ 60/ 1	45-25	220-400	7.15/ 8.10	11-15	18.0		14.2	20	4.75	78.4	10.2	R-449a	176
CIM 1137A	208-230/ 60-1	50-30	175-400	7.15/ 8.10	11-15	19.0		9.5	15	5.1	51.0	6.7	R-404a	40
CIM 1137W	208-230/ 60/ 1	50-30	250	7.15/ 8.10	11-15	19.0	140	8.9	15	4.1	51.0	6.7	R-404a	32
CIM 1137R	208-230/ 60/ 1	50-30	220-400	7.15/ 8.10	11-15	19.0		9.9	15	4.9	51	6.7	R-404a	176
CIM 1446A49	208/ 230/ 60/ 1	45/ 25	175-400	14.3/ 16.2	17-20	14.4		19.2	30	4.4	73	13.9	R-449a	58
CIM 1446W	208/ 230/ 60/ 1	50-30	250	14.3/ 16.2	16-19	14.7	103.96	18.9	30	3.72	82.0	14.4	R-404a	30
CIM 1446R	208-230/ 60/ 1	50-30	220-400	14.3/ 16.2	17-20	14.4		19.9	30	4.35	82.0	14.4	R-404a	250
CIM 1446R49	208-230/ 60/ 1	45-25	220-400	14.3/ 16.2	17-20	15.2		19.7	30	4.29	82.0	14.4	R-449a	250
CIM 1447A	208-230/ 60/ 1	50-30	175-400	14.3/ 16.2	16-19	14.4		13.7	20	4.4	66.0	9.5	R-404A	58
CIM 1447W	208-230/ 60/ 3	50-30	250	14.3/ 16.2	16-19	14.7	103.9	12.6	20	3.72	65.5	9.4	R-404a	30
CIM 1447R	208-230/ 60/ 3	50-30	220-400	14.3/ 16.2	15-18	15.0		13.6	20	4.35	65.5	9.4	R-404a	250
CIM 1545A	220-240/ 50/ 1	50-30	175-400	14.3/ 16.2	17-20	14.8		18.8	30	4.49	64.0	13.6	R-404a	58
CIM 1545W	220-240/ 50/ 1	50-30	250	14.3/ 16.2	16-19	14.3	101.7	17.9	30	3.67	64.0	13.6	R-404a	30
CIM 1545R	220-240/ 50/ 1	50-30	220-400	14.3/ 16.2	15-18	14.6		19.4	30	4.03	64.0	13.6	R-404a	250
CIM 1845A	220-240/ 50/ 1	50-30	175-400	14.3/ 16.2	17-20	14.0		21.0	30	4.57	75.9	15.4	R-404a	54
CIM 1845W	220-240/ 50/ 1	50-30	250	14.3/ 16.2	15-18	14.5	109.3	18.1	25	3.67	75.9	13.8	R-404a	30
CIM 1845R	220-240/ 50/ 1	50-30	220-400	14.3/ 16.2	15-18	14.4		21.6	35	4.09	75.9	15.4	R-404a	292
CIM 2046W	208-230/ 60/ 1	50-30	250	14.3/ 16.2	15-18	14.8	134.2	24.1	40	3.52	96.0	18.6	R-404a	42
CIM 2046R	208-230/ 60/ 1	50-30	220-400	14.3/ 16.2	15-18	14.9		25.6	40	4.31	96.0	18.6	R-404a	292
CIM 2046R49	208-230/ 60/ 1	45-25	220-400	14.3/ 16.2	15-18	15.0		22.5	35.0	4.44	96.0	16.7	R-449A	292
CIM 2047W	208-230/ 60/ 3	50-30	250	14.3/ 16.2	17-20	14.8	134.2	15.1	25	3.52	75.0	11.4	R-404a	42
CIM 2047R	208-230/ 60/ 3	50-30	220-400	14.3/ 16.2	17-20	14.9		16.6	25	4.31	75.0	11.4	R-404a	292

Wiring Diagram

CIM 115V and 230V, 60Hz, SINGLE PHASE, SINGLE EVAPORATOR AIR AND WATER COOLED UNITS

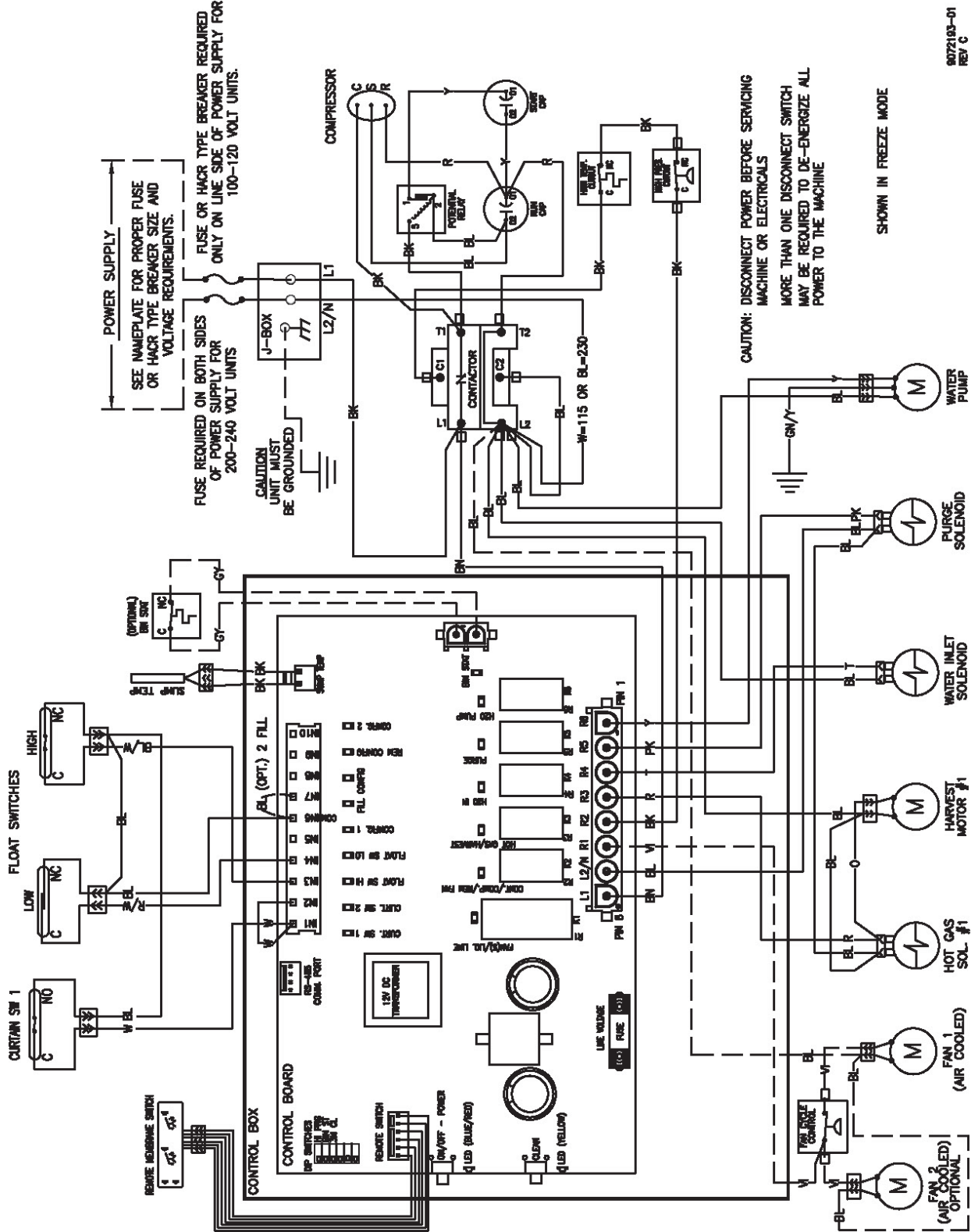

CIM 220V - 240V, 50Hz, SINGLE PHASE, SINGLE EVAPORATOR PLATE AIR AND WATER COOLED UNITS

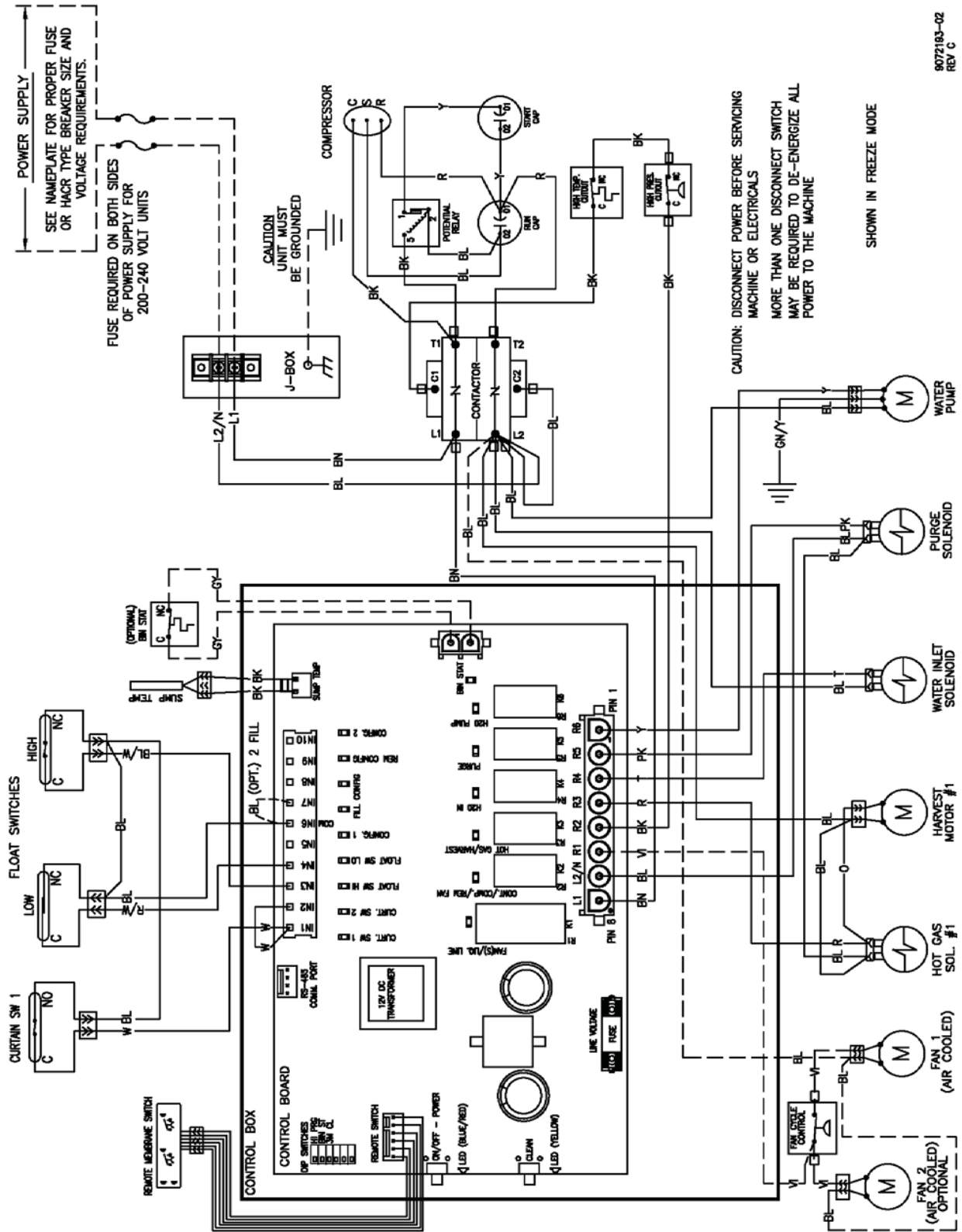

9072193-02
REV C

CIM 115V and 230V, 60Hz, THREE PHASE, SINGLE EVAPORATOR AIR AND WATER COOLED UNITS

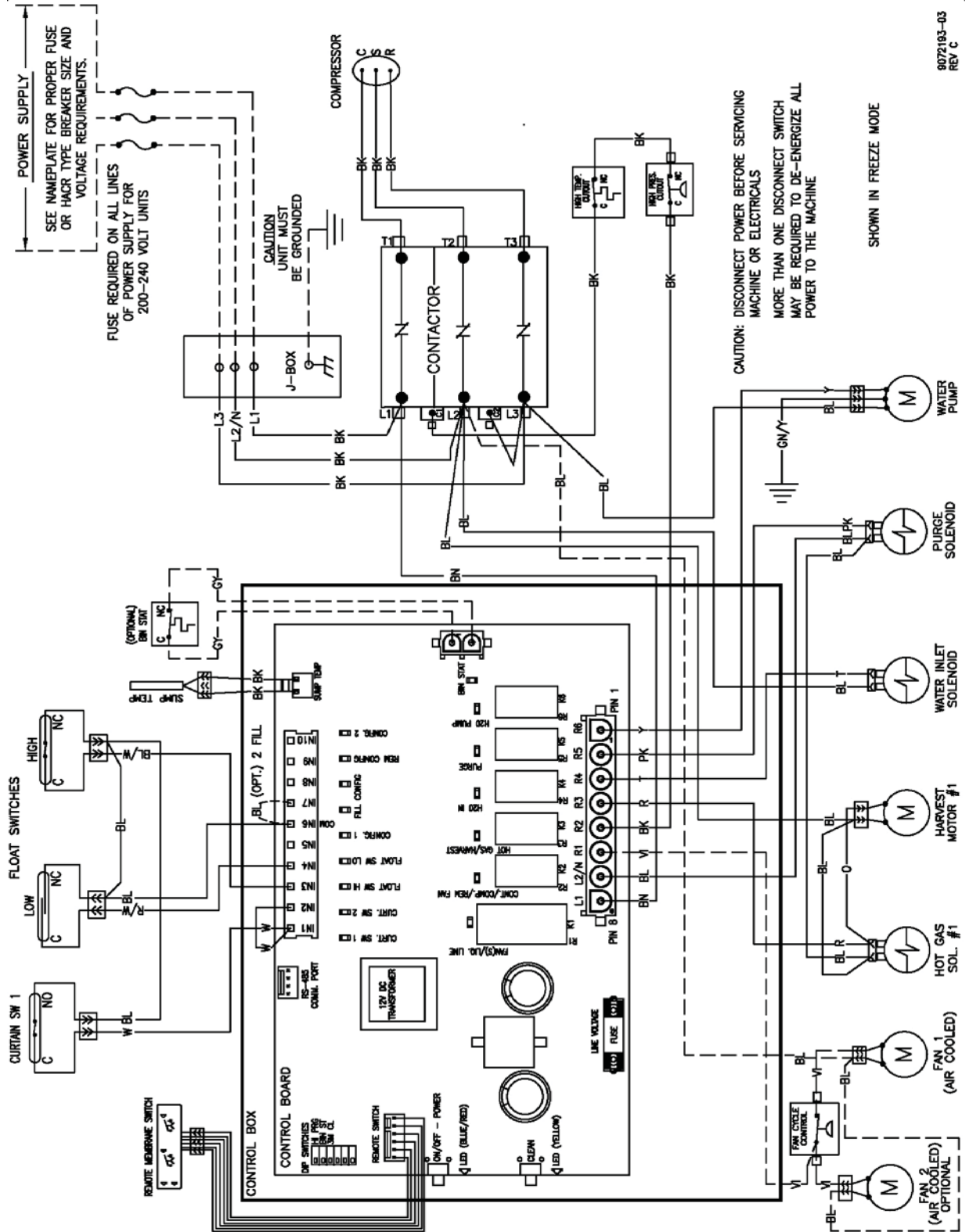

9072193-03
REV C

CIM 115V and 230V, 60Hz, SINGLE PHASE, SINGLE EVAPORATOR PLATE REMOTE COOLED UNITS

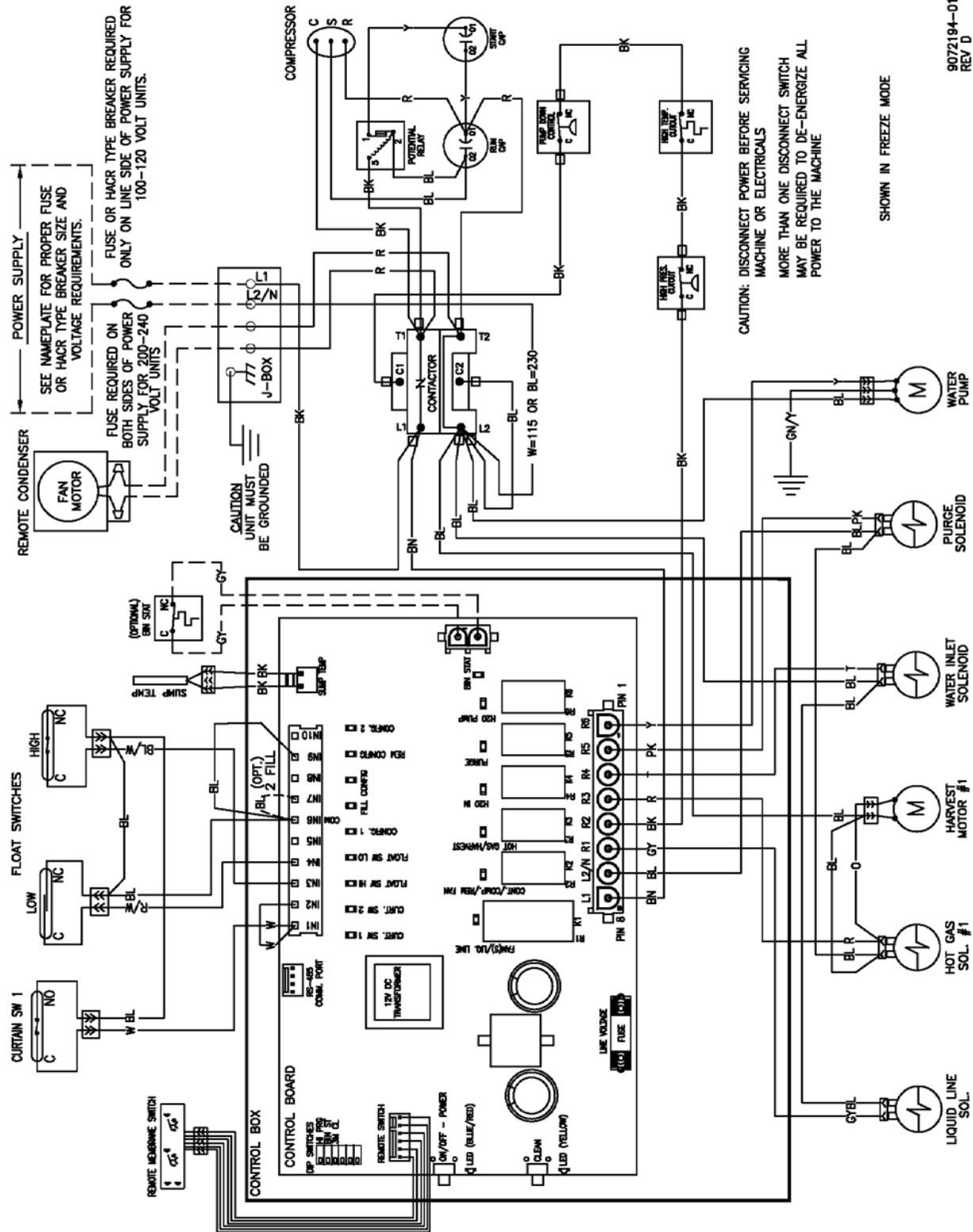

CIM 230V, 60Hz, SINGLE PHASE, DUAL EVAPORATOR AIR AND WATER COOLED UNITS

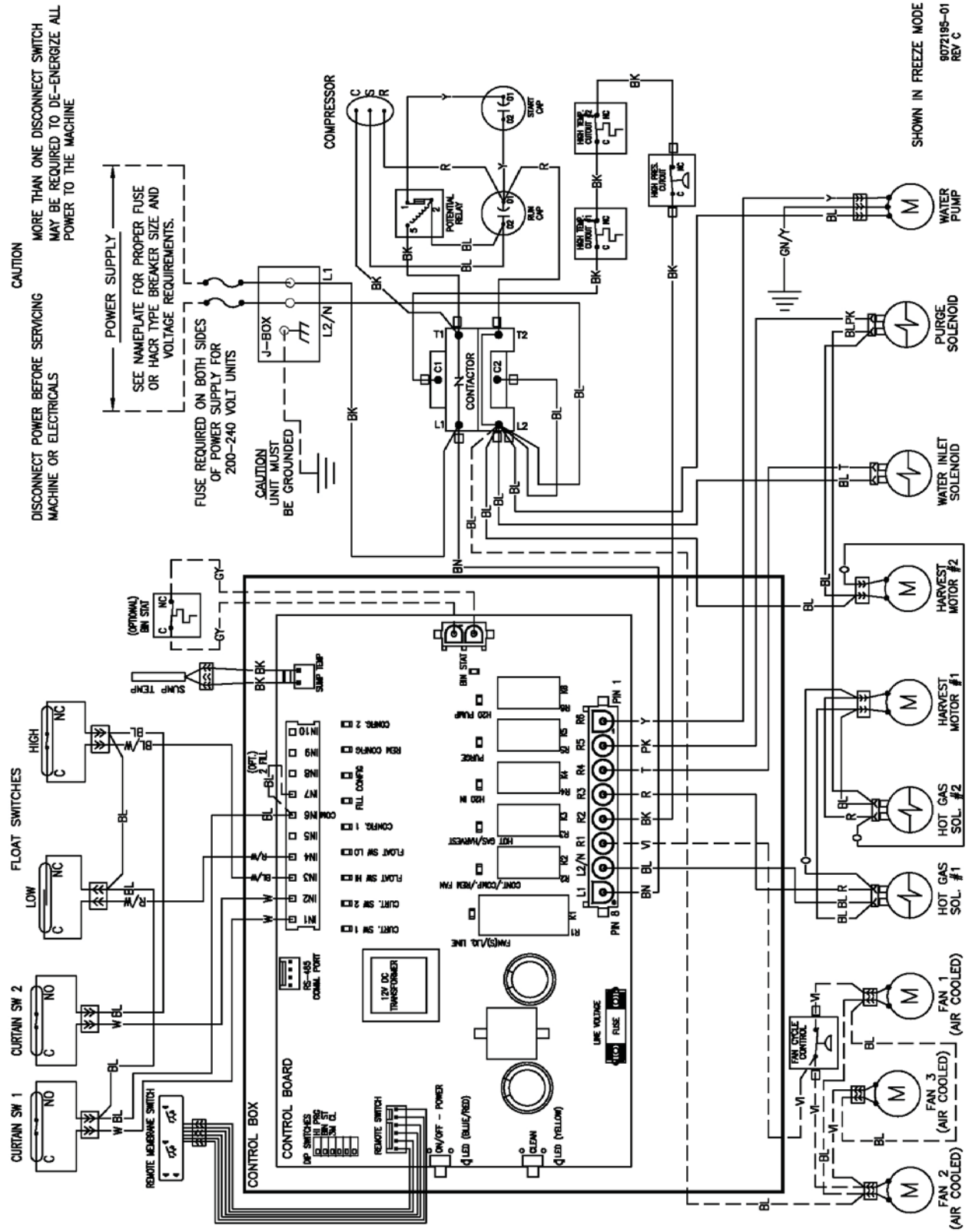

CIM 230V, 60Hz, THREE PHASE, DUAL EVAPORATOR REMOTE COOLED UNITS

