

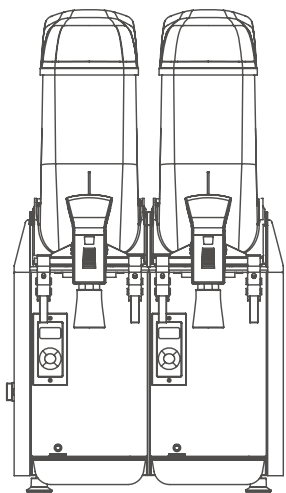

*Frozen Drink
& Cocktail
Machines*



*all
you
can
slush*

ELMECO
FROZEN BEVERAGE SOLUTIONS
• SINCE 1961 •

Exclusive Features

Double augers for Better mix
Total cold system
"Seal-Less" drive shaft system which eliminates mandatory preventive maintenance
Electronic system, density control and auto diagnostic
Equipped with automatic cleaning and sanitizing valves



PROPANE GAS R290
BRUSHLESS FUN MOTOR
REMOVABLE AIR FILTER
SELF CLEANING
CONDENSER



First
class

Particularly suitable for locations with a large number of users, *Elmeco First Class* is perfect for granita, frozen coffee and tea, semi-frozen and frozen desserts, cocktails, sorbets, sangria, lemonade and much, much more. Thanks to the patented "total cold" system, the product is kept at a constant temperature, right down to the very last drop, guaranteeing optimal product quality and minimal wastage. **Completely** drive shaft seal free make the machine is to disassembly and clean. An efficient, electronic board makes it simple and intuitive to use.

Exclusive customization with Led Backlit light panel

Elmeco First Class is available in two different color and it is possible to customize with your logo, graphics or advertising messages.

The addition of the LED backlight panel allows for complete customisation and a fresher, more appealing look.



Refill system. Maximize your output production

Elmeco Refill is a handy bag-in-box auto-fill system, easy to set up on the existing machines (FC2 and FC3). This additional equipment maximizes output production by keeping machine bowls full at all times and reinforces merchandizing effect. Eliminates potential human errors in process of premixing water and syrup.



IDEAL FOR CONVENIENCE STORES AND HIGH-DEMAND BEVERAGE SERVICE

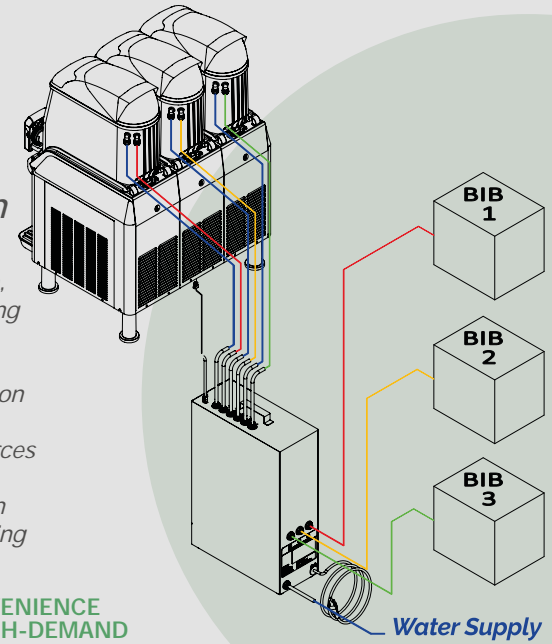

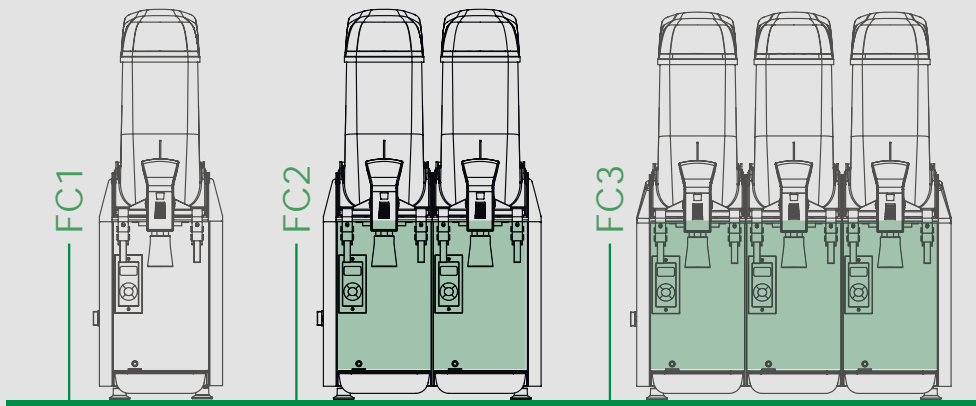

○ ● COLOURS AVAILABLE ■ FRONT LED BACKLIT LIGHT PANEL AVAILABLE



5 years on compressor parts (USA / Canada only)
 3 years on electronic parts (USA / Canada only)
 2 years on functional parts
 1 years on labor

DIMENSION			WEIGHT		CAPACITY		POWER		VOLTAGE	
H	W	D	KG.	LB.	LT.	GAL.	W	HP	V/HZ	
FC1	771 mm	240 mm	566 mm	31	68.30	12	3.17	500	0.67	220/240/50
	30.35 inc	9.45 in	22.28 in							220/60
FC2	771 mm	430 mm	548 mm	52	114.60	24	6.34	930	1.24	220/240/50
	30.35 inc	16.93 in	21.57 in							220/60
FC3	771 mm	620 mm	548 mm	64	141.10	36	9.51	1150	1.54	220/240/50
	30.35 inc	24.4 in	21.57 in							115/60

Keep your First Class tanks full at all times

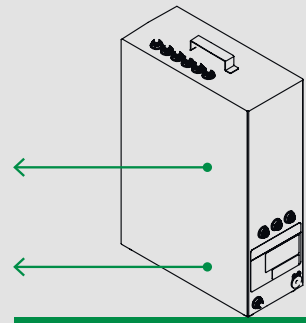

AUTO-FILL SYSTEM BENEFITS

- Bag-n-box (BIB) auto fill system product at rate of 2-3 oz per sec. (varies for different types of concentrate);
- Contains pumps, tubes and solenoids in one, easy to handle box;
- Power cord included, must be plugged in individually from the machine (110V/60Hz);
- Equipped with automatic alarm when syrup BIB empty or insuinet water pressure provided;
- Equipped with automatic cleaning and sanitizing valves;
- Equipped with shurflo brix pumps at 3:1, 4:1 or 5:1.



info@elmeco.com
www.elmeco.com

ITALY HEADQUARTER

*via Circumvallazione Esterna, 12
80025 Casandrino,
Napoli, Italy
Tel +39 081 5055724
Fax +39 081 5055726*

AMERICA DISTRIBUTION CENTER

*652 Griffith Road Suite E
Charlotte NC
28217, USA
Tel: +1 877 435 6326
Fax +1 704 666 5141*

INDIA DISTRIBUTION CENTER

*5th Floor, Sangeet Plaza
Marol Maroshi Road
Opp Marol Fire Brigade
Andheri (East) Mumbai
India 400 059*